

PRODUCT FEATURES

RATED PRESSURE 150 PSIG A

Turn-Act's Guided Rod Cylinder combines high strength with light weight and can be customized to fit your specific needs. Turn-Act's exclusive ENERSORB™ piston is self-lubricating, up to 50% quieter than regular pistons and provides unparalleled repeatable stroke.

ENERSORB™ Piston (Patent Pending)

- Innovative design integrates seal, wear band, magnet and bumpers into one component
- High energy absorption
- Bumpers reduce noise more than 50%
- Extended cycle life from unique blend of urethane material
- Excellent for non-lubrication applications
- Unparalleled repeatable stroke

Body

- High strength, light weight extruded aluminum
- Hard anodized internal bore for longer cylinder life

Switches

- Reed, PNP and NPN electronic
- Low profile mounting below body surface
- Integral LED

Extruded Mounting Slots

- Integrated for flexible mounting

Tooling Plate

- High strength hard anodized aluminum
- Available with tapped or counterbored holes and dowel locators
- Blank or custom plates also available

Piston and Guide Rods

- High strength, precision chrome-plated steel
- Superior wear resistance
- Stainless steel rods available

Rod Wiper

- Durable urethane construction provides secondary seal

Piston and Guide Rod Bearings

- Durable and self-lubricating, providing rigid support
- Linear ball bearings optional
- Other bearing materials available

Rod Seal

- Bubble tight nitrile seal

STANDARD OPTIONS

- Stop Collars
- Bridge Plate
- Magnetic Piston for switch
- Clean Room Option (Consult factory)

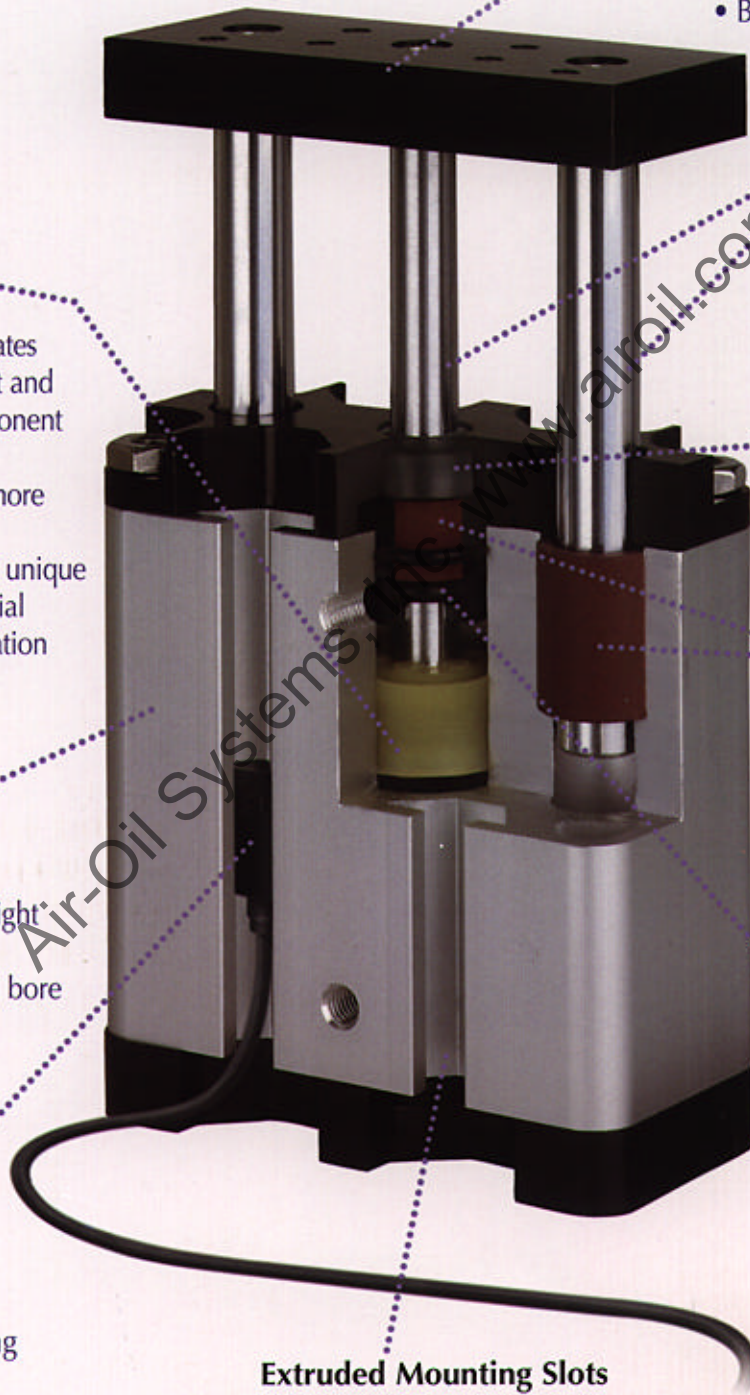

DIMENSIONAL DATA

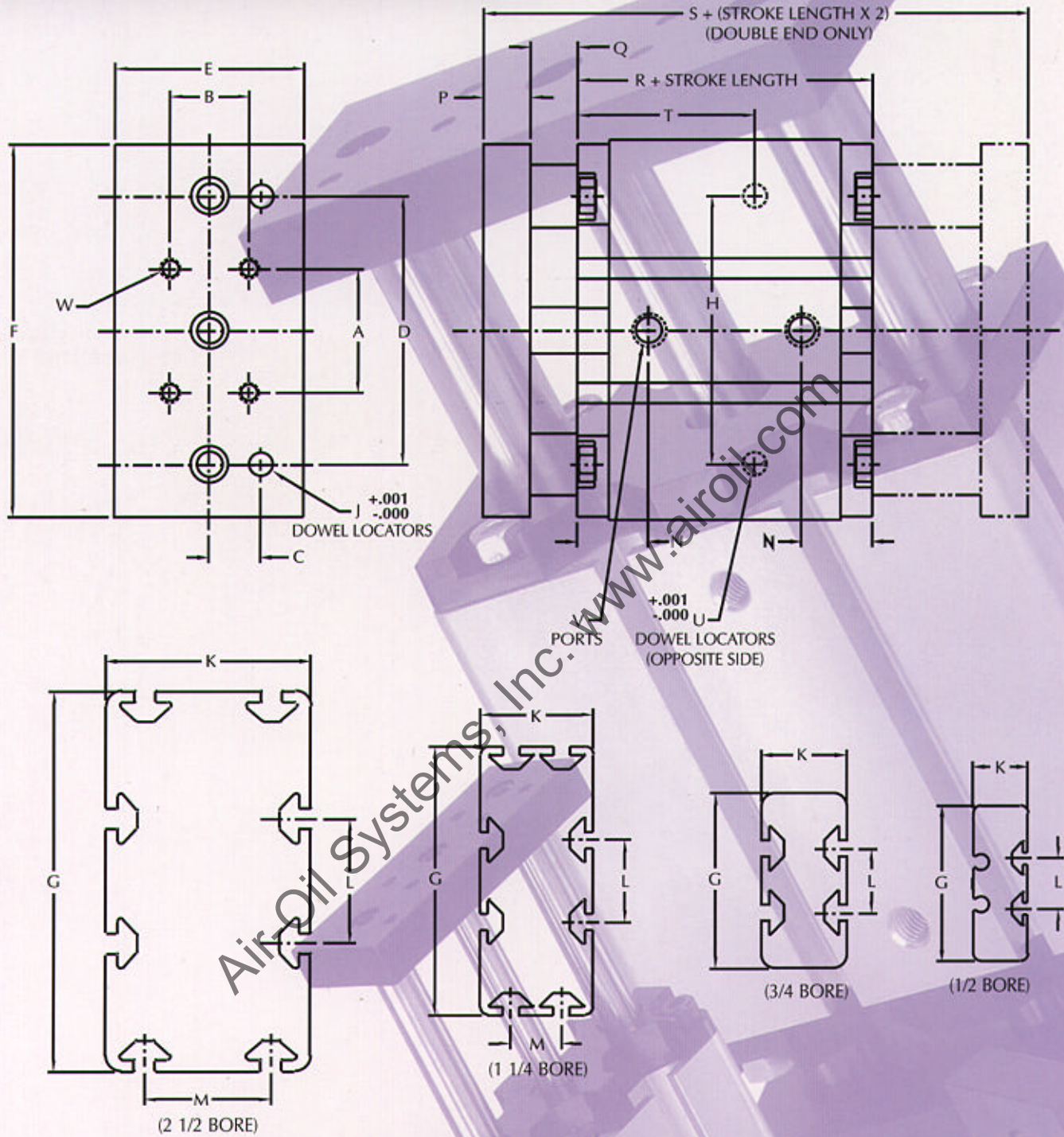

DIMENSIONAL SPECIFICATIONS

BORE	A	B	C	D	E	F	G	H	J	K	L	M	N	P	Q	R	S	T	U	V	W
1/2	.81	.44	.25	1.50	.75	2.47	2.50	1.50	.126	.88	.81	n/a	.63	.38	.50	2.00	3.75	.88	.126	#10-32	#8-32
3/4	1.03	.63	.38	1.88	1.13	2.75	2.81	1.88	.188	1.36	1.03	n/a	.71	.38	.50	2.43	4.18	1.31	.188	#10-32	1/4-20
1 1/4	1.31	.63	.50	2.63	1.50	3.69	4.31	2.63	.251	1.80	1.31	.81	.90	.50	.50	2.93	4.93	1.63	.251	1/8 NPT	1/4-20
2 1/2	2.00	1.25	.81	4.32	3.00	6.00	6.13	4.32	.376	3.25	2.00	2.00	1.13	.75	.75	3.69	6.69	2.81	.376	1/4 NPT	5/16-18

DEFLECTION AND FORCE DATA

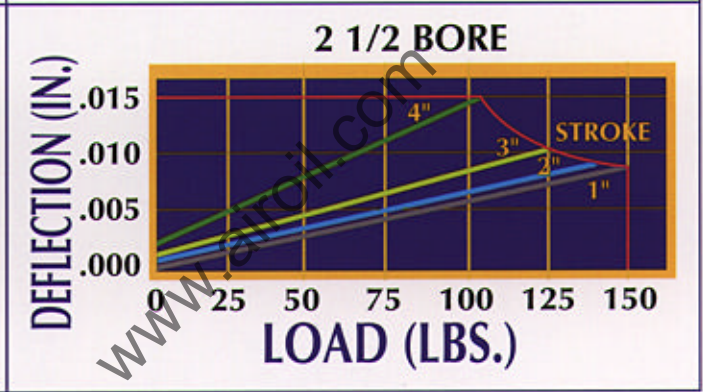
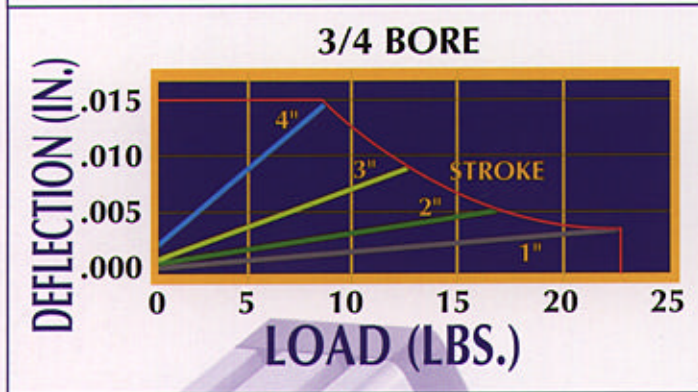
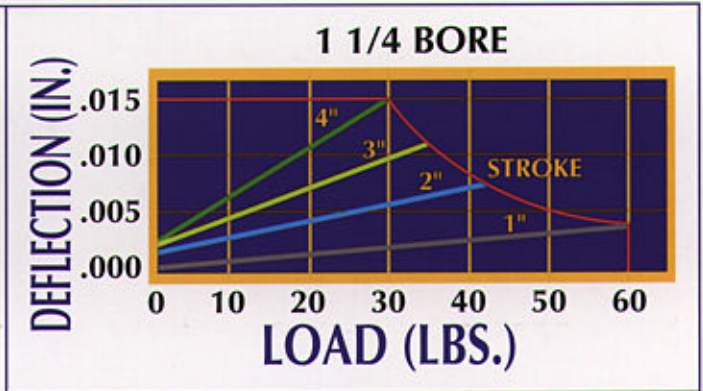
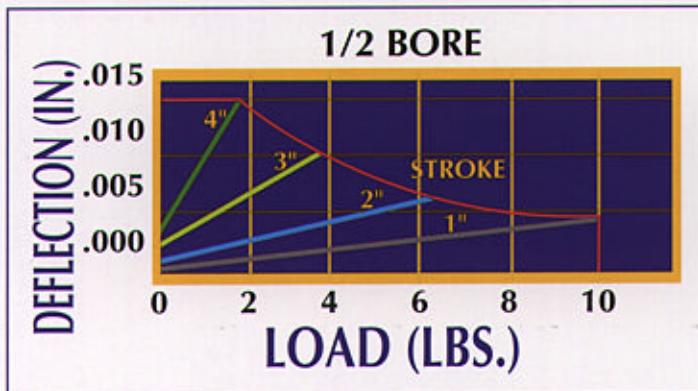

FORCE CHART

BORE		THEORETICAL FORCE (LBS.) AT:		
		50 PSI	100 PSI	150 PSI
1/2	Extend	9.8	19.6	29.4
	Retract	8.4	16.8	25.3
3/4	Extend	22.1	44.2	66.3
	Retract	18.3	36.5	54.8
1 1/4	Extend	61.4	122.7	184.1
	Retract	51.6	103.1	154.7
2 1/2	Extend	245.4	490.9	736.3
	Retract	223.3	446.7	670.0

How To Use Deflection Charts

When selecting cylinder size, we recommend choosing parameters underneath the upper limit line (red). Selections above the upper limit line may adversely affect cylinder life or operation.

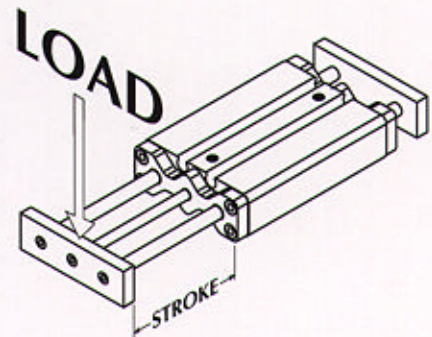

SWITCHES

HALL EFFECT SWITCH PNP SOURCING

VOLTAGE
6-24 VDC
CURRENT
200 mA. MAX

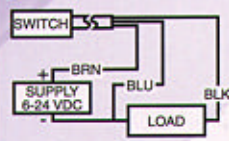

HALL EFFECT SWITCH NPN SINKING

VOLTAGE
6-24 VDC
CURRENT
200 mA. MAX

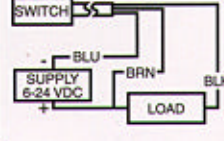

AC/DC REED SWITCH

VOLTAGE
5-120 VAC/VDC
CURRENT
1 mA. MIN TO
30 mA. MAX

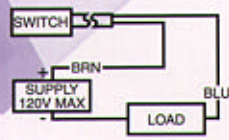

Special Note:

1. Switches will be permanently damaged if operated without a load.
2. Do not exceed ratings or short circuit load.

PART NUMBERS

BORE	PNP SOURCING	NPN SINKING	REED
1/2	GRP-05	GRN-05	GRR-05
3/4	GRP-07	GRN-07	GRR-07
1 1/4	GRP-07	GRN-07	GRR-12
2 1/2	GRP-25	GRN-25	GRR-25

These part numbers represent one switch and its mounting hardware.

ORDER FORM

Series Bore Bearing Type Guide Type Stroke Option Option

GR - - - - ##.## - -

1 2 3 4 5 6 6

1 GR Guided Rod

5 Designate Stroke With Two Decimal Places
Example 2" = 2.00

2

05	1/2 Bore
07	3/4 Bore
12	1 1/4 Bore
25	2 1/2 Bore

3

C	Standard Composite
B	Linear Ball

4

SE	Single End
SG	Single End, 1/8" Tooling Plate Gap
DE	Double End
DG	Double End, 1/8" Tooling Plate Gap

6

N10	Stop Collars (Adjust Retract)
N11	Stop Collars (Adjust Extend)
N22	Bridge Plate
N23	Tapped Tooling Plate(s)
N24	Counterbored Tooling Plate(s)
N26	Blank Tooling Plate(s)
N30	Magnetic Piston (order switches separately)
N40	Stainless Steel Piston & Guide Rods

OPTIONS & MOUNTING

STOP COLLARS

BORE	A	B
1/2	.44	.69
3/4	.50	.88
1 1/4	.55	1.13
2 1/2	.75	1.75

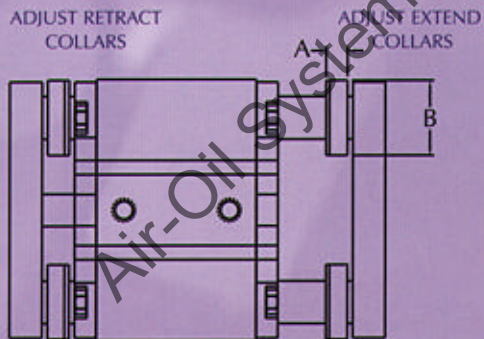

NOTE: ADJUSTABLE COLLARS MAY INTERFERE WHEN COLLAR IS WIDER THAN TOOLING PLATE GAP

MOUNTING NUTS

BORE	A	B	C	D	E
1/2	.75	.44	.38	.16	#8-32
3/4	1.13	.63	.56	.25	1/4-20
1 1/4	1.13	.63	.56	.25	1/4-20
2 1/2	1.75	1.25	.88	.25	5/16-18

BRIDGE PLATE

BORE	A	B
1/2	3.75	1.94
3/4	4.18	2.31
1 1/4	4.93	2.66
2 1/2	6.69	3.63

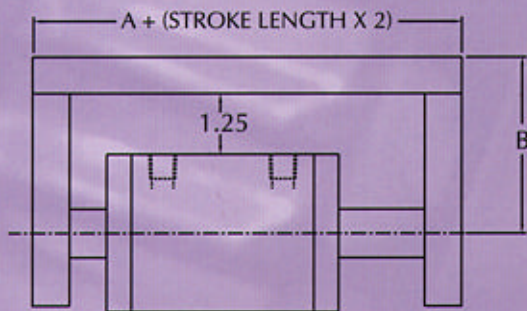

NOTE: BRIDGE PLATE WIDTH IS THE SAME AS THE STANDARD TOOLING PLATE

