

# PZN-plus

Pneumatic • 3-Finger Centric Gripper • Universal Gripper



**Sizes**  
40 ... 300



**Weight**  
0.13 kg ... 46 kg

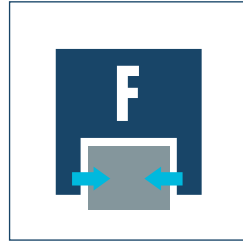

**Gripping force**  
255 N ... 35500 N

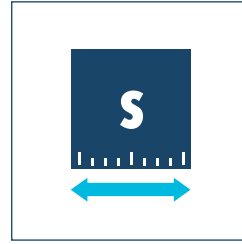

**Stroke per finger**  
2 mm ... 35 mm



**Workpiece weight**  
1.3 kg ... 127.5 kg

## Application example

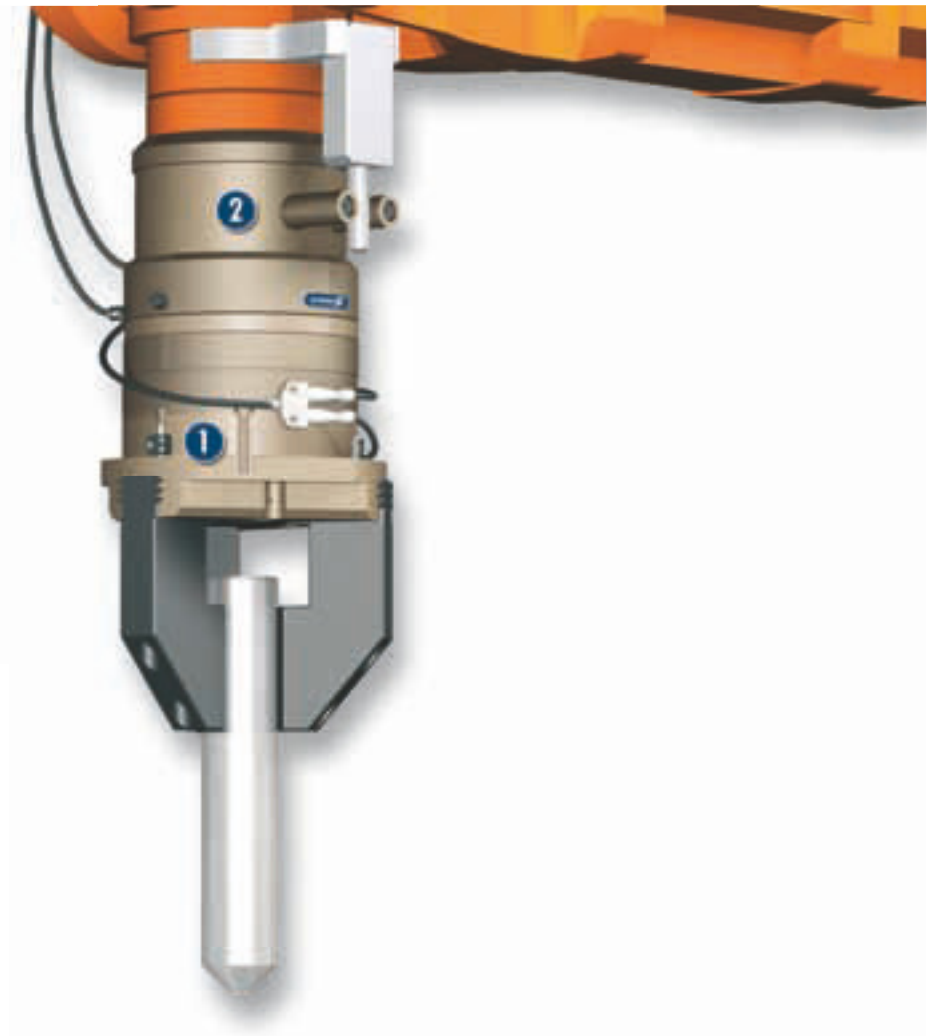

Insertion tool for assembling small to medium-sized axles. Thanks to the rotary feed-through, the axles can be turned several times to an unlimited extent ( $> 360^\circ$ ). Slip ring contacts integrated in the rotary feed-through reliably supply the gripper with power.

- 1 3-Finger Centric Gripper PZN-plus
- 2 Rotary feed-through DDF

### Universal Gripper

universal Concentric Gripper with high gripping force and maximum moments thanks to multi-tooth guidance

### Field of application

Multi-purpose thanks to the diverse range of accessories. Can also be used in fields of application with special requirements to the gripper (temperature, chemical resistance, dirt, and many more).

### Your advantages and benefits

#### Robust multi-tooth guidance

for precise handling

#### High maximum moments possible

suitable for using long gripper fingers

#### Wedge-hook design

for high power transmission and synchronized gripping

#### Air supply via hose-free direct connection or screw connections

for the flexible supply of compressed air in all automation systems

#### Comprehensive sensor accessory program

for versatile interrogation possibilities and control of stroke position

#### Manifold options

for perfect adaption to your case of application (dust protection, high temperature, anti-corrosion and many more)



### General note to the series

#### Principle of function

Wedge-hook kinematics

#### Housing material

Aluminum alloy, hard-anodized

#### Base jaw material

Steel

#### Actuation

pneumatic, with filtered compressed air (10 microns): dry, lubricated or non-lubricated

Pressure medium: Required quality class of compressed air according to

DIN ISO 8573-1: 6 4 4

#### Warranty

36 months (details, general terms and conditions and operation manuals can be downloaded under [www.schunk.com](http://www.schunk.com))

#### Scope of delivery

Brackets for proximity switches, centering sleeves, O-rings for direct connection, assembly and operating manual with manufacturer's declaration

## Sectional diagram

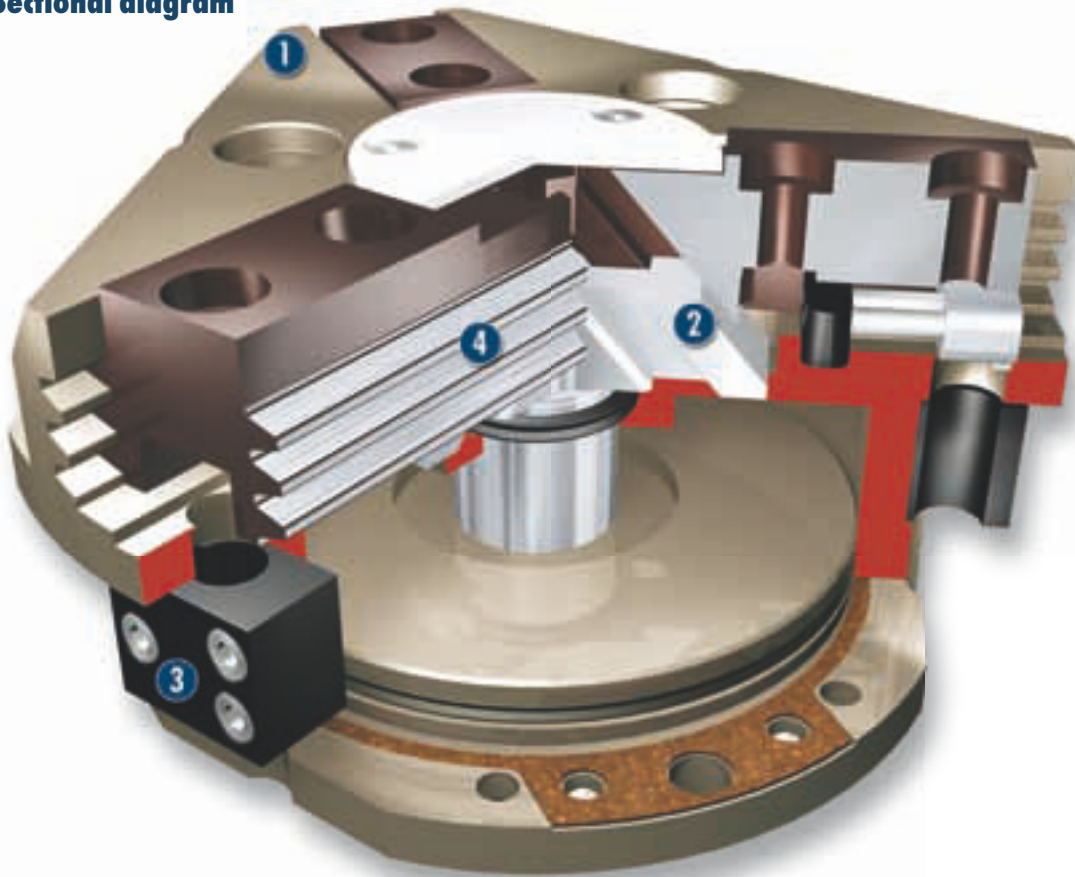

- 1 Housing**  
weight-optimized through application of hard-anodized, high-strength aluminum alloy
- 2 Wedge-hook design**  
for high power transmission and centric gripping
- 3 Sensor system**  
Brackets for proximity switches and adjustable control cams in the housing
- 4 Multiple-tooth guidance**  
precise gripping through base jaw guidance with a high load capacity and a minimum play

## Functional description

The piston is moved up and down by compressed air. Through its angled active surfaces, the wedge hook transforms this movement into the lateral, synchronous gripping movement of both base jaws.

## Options and special information

### Dust-protection version

Absolutely sealed, increased degree of protection against the ingress of materials, for use in dusty environments

### Anti-corrosion version

for use in corrosion-inducing atmospheres

### High-temperature version

for use in hot environments

### Force intensified version

if higher gripping forces are required

### Accessories

Accessories from SCHUNK – the suitable supplement for maximum functionality, reliability and performance of all automation modules.

Sensor system



Fittings



Universal intermediate jaw



Compensation unit



Protection cover



Sensor cables



Quick-change Jaw System



Sensor Distributor



Pressure maintenance valve



Finger blanks



Force measuring jaws



Analog position sensor



Flexible Position Sensor



① For the exact size of the required accessories, availability of this size and the designation and ID, please refer to the additional views at the end of the size in question. You will find more detailed information on our accessory range in the "Accessories" catalog section.

### General note to the series

#### Gripping force

is the arithmetic total of the gripping force applied to each finger at distance P (see illustration) measured from the upper edge of the gripper.

#### Finger length

The finger length is measured from the upper edge of the gripper housing in the direction of the main axis.

#### Repeat accuracy

is defined as the spread of the limit position after 100 consecutive strokes.

#### Workpiece weight

The recommended workpiece weight is calculated for a force-type connection with a coefficient of friction of 0.1 and a safety factor of 2 against slippage of the workpiece on acceleration due to gravity g. Considerably heavier workpiece weights are permitted with form-fit gripping.

#### Closing and opening times

Closing and opening times are purely the times that the base jaws or fingers are in motion. Valve switching times, hose filling times or PLC reaction times are not included in the above times and must be taken into consideration when determining cycle times.

# PZN-plus 160

Pneumatic • 3-Finger Centric Gripper • Universal Gripper



## Gripping force, I.D. gripping

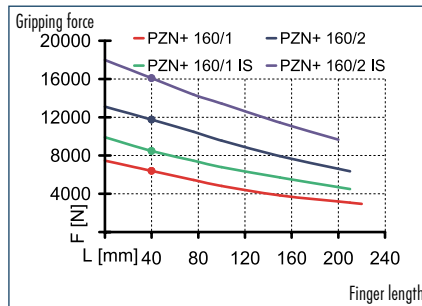

## Gripping force, O.D. gripping

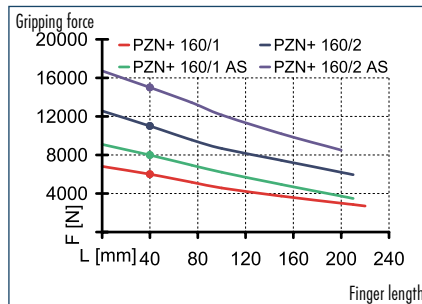

## Finger load

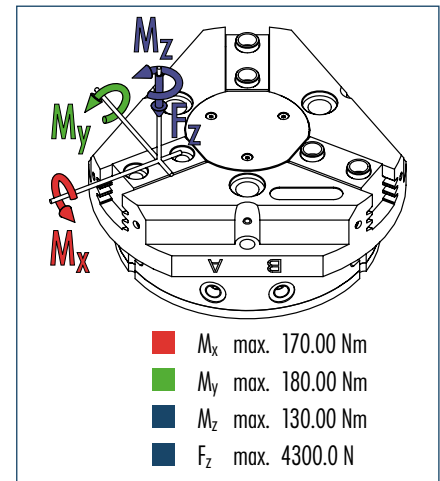

① The indicated moments and forces are static values, apply per base jaw and may occur simultaneously.  $M_y$  may arise in addition to the moment generated by the gripping force itself. If the max. permitted finger weight is exceeded, it is imperative to throttle the air pressure so that the jaw movement occurs without any hitting or bouncing. Service life may be reduced.

## Technical data

Description	PZN-plus 160-1	PZN-plus 160-2	PZN-plus 160-1-AS	PZN-plus 160-2-AS	PZN-plus 160-1-IS	PZN-plus 160-2-IS
ID	0303314	0303414	0303514	0303614	0303544	0303644
Stroke per finger [mm]	16	8	16	8	16	8
Closing force [N]	6000	11000	7990	15010		
Opening force [N]	6390	11750			8480	16090
Min. spring force [N]			1990	4010	2090	4340
Weight [kg]	5.6	5.6	8	8	8	8
Recommended workpiece weight [kg]	30	55	30	55	30	55
Air consumption per double stroke [cm <sup>3</sup> ]	520	520	875	875	875	875
Min./max. operating pressure [bar]	2/8	2/8	4/6.5	4/6.5	4/6.5	4/6.5
Nominal operating pressure [bar]	6	6	6	6	6	6
Closing/opening time [s]	0.5/0.5	0.5/0.5	0.4/0.8	0.4/0.8	0.8/0.4	0.8/0.4
Max. permitted finger length [mm]	220	210	210	200	210	200
Max. permitted weight per finger [kg]	3.5	3.5	3.5	3.5	3.5	3.5
IP class	40	40	40	40	40	40
Min./max. ambient temperature [°C]	-10/90	-10/90	-10/90	-10/90	-10/90	-10/90
Repeat accuracy [mm]	0.02	0.02	0.02	0.02	0.02	0.02
Cleanroom class						
ISO-classification 14644-1	5	5	5	5	5	5

## OPTIONS and their characteristics

Dust-protection version	37303314	37303414	37303514	37303614	37303544	37303644
IP class	64	64	64	64	64	64
Weight [kg]	6.5	6.5	8.9	8.9	8.9	8.9
Anti-corrosion version	38303314	38303414	38303514	38303614	38303544	38303644
High-temperature version	39303314	39303414	39303514	39303614	39303544	39303644
Min./max. ambient temperature [°C]	-10/130	-10/130	-10/130	-10/130	-10/130	-10/130
Force intensified version	PZN-plus 160-1-KVZ	PZN-plus 160-2-KVZ	PZN-plus 160-1-AS-KVZ		PZN-plus 160-1-IS-KVZ	
ID	0372205	0372215	0372225		0372245	
Closing force [N]	10800	19800	12730			
Opening force [N]	11500	21150			13590	
Weight [kg]	7.8	7.8	9.6		9.6	
Maximum pressure [bar]	8	8	6		6	
Max. permitted finger length [mm]	125	100	100		100	
Precision version	0303344	0303444	0303494	0303594		

## Main view

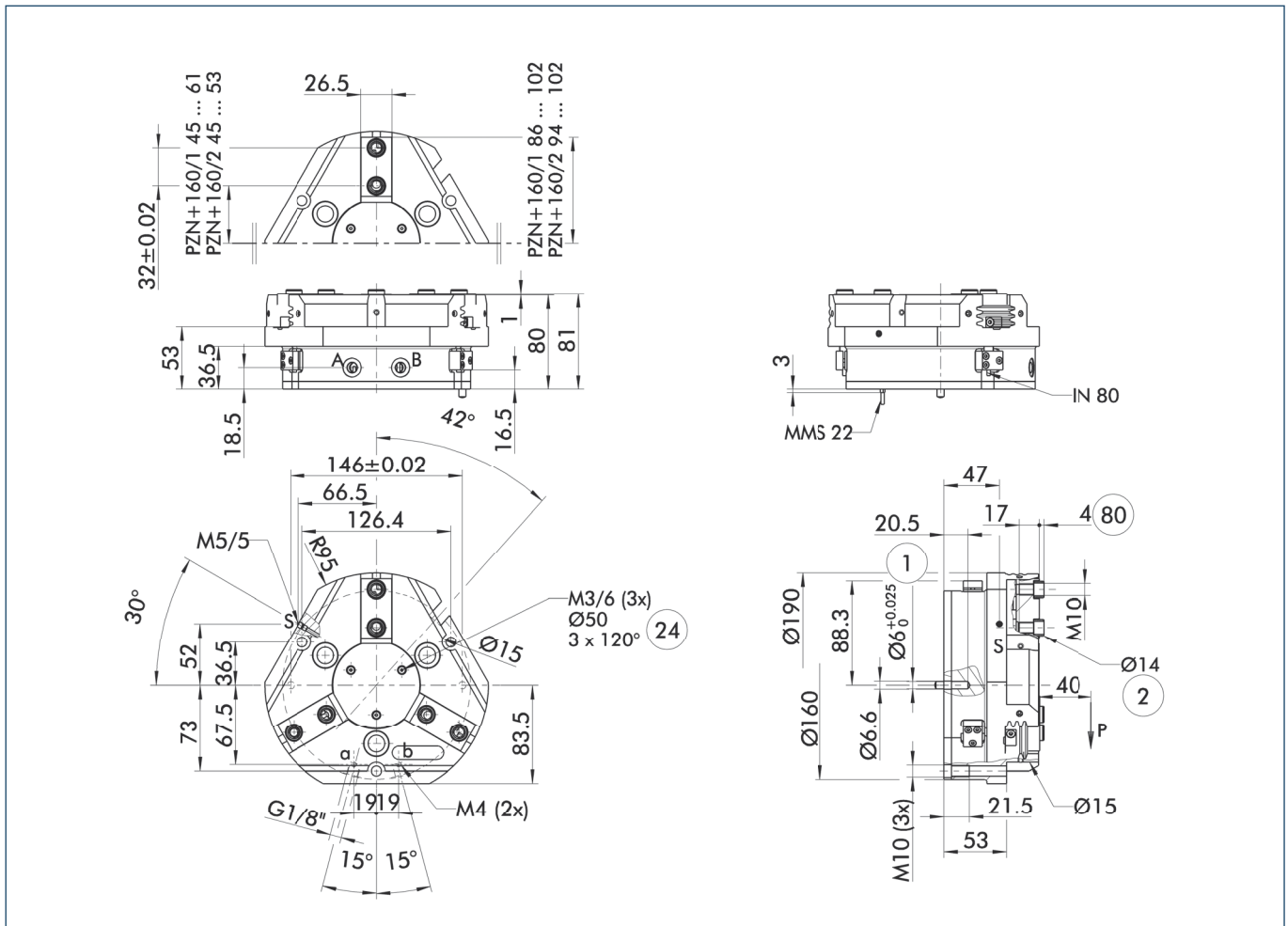

The drawing shows the gripper in the basic version with closed jaws, the dimensions do not include the options described below.

① The SDV-P pressure maintenance valve can also be used for I.D. or O.D. gripping alternatively or in addition to the spring-loaded, mechanical gripping force maintenance device (see "Accessories" catalog section).

- A, a Main/direct connection, gripper opening
- B, b Main/direct connection, gripper closing
- S Air purge connection
- ① Gripper connection
- ② Finger connection
- ②④ Bolt circle
- ⑧⑩ Depth of the centering sleeve hole in the matching part

## Hose-free direct connection

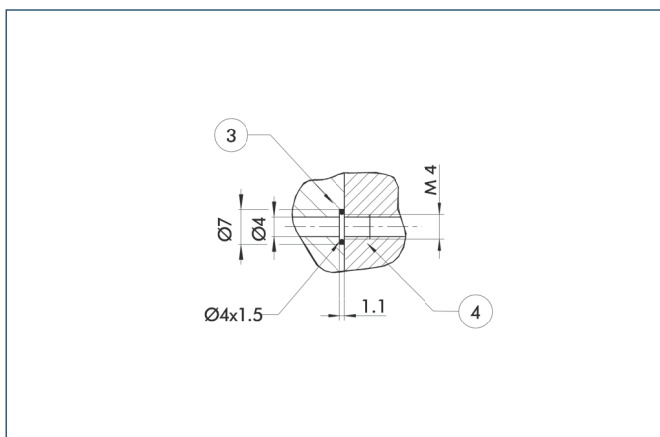

- ③ Adapter
- ④ Gripper

The direct connection is used for supplying compressed air without hoses. Instead, the pressure medium is fed through bore-holes in the mounting plate.

## AS/IS gripping force maintenance device

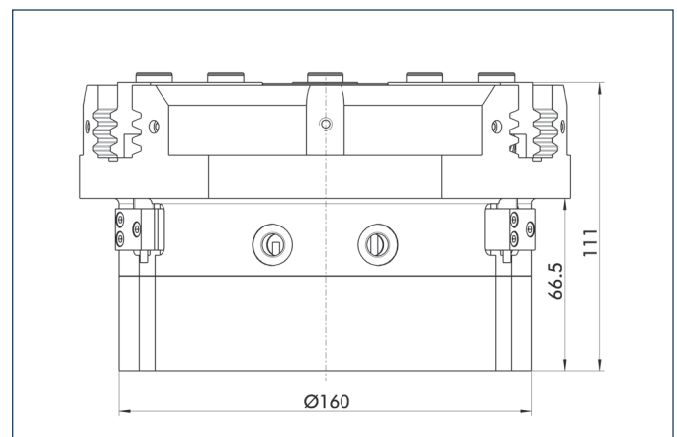

The mechanical gripping force maintenance device ensures a minimum gripping force even in case of pressure drop. This acts as closing force in the AS version, and as opening force in the IS version. In addition, the gripping force maintenance device can also be used for increasing the gripping force or for single-acting gripping.



# PZN-plus 160

Pneumatic • 3-Finger Centric Gripper • Universal Gripper

## Dust-protection version

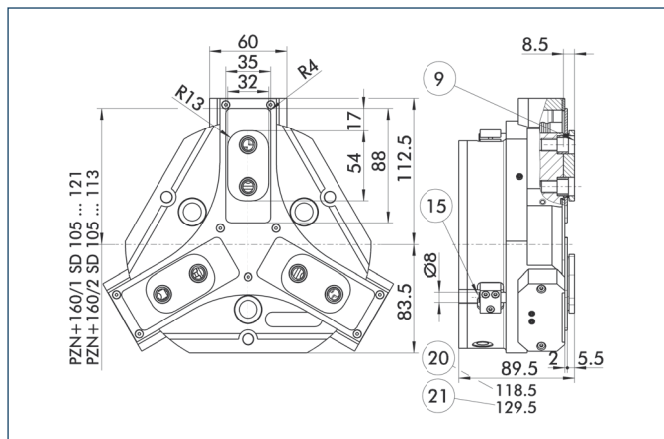

- ⑨ For mounting screw connection diagram, see basic version
- ⑩ For AS / IS version
- ⑪ Sealing bolt
- ⑫ Applies for KVZ version

The "dust-protection" option increases the degree of protection against penetrating substances. The screw connection diagram shifts by the height of the intermediate jaw. The finger length is still measured from the upper edge of the gripper housing.

## Force intensified version

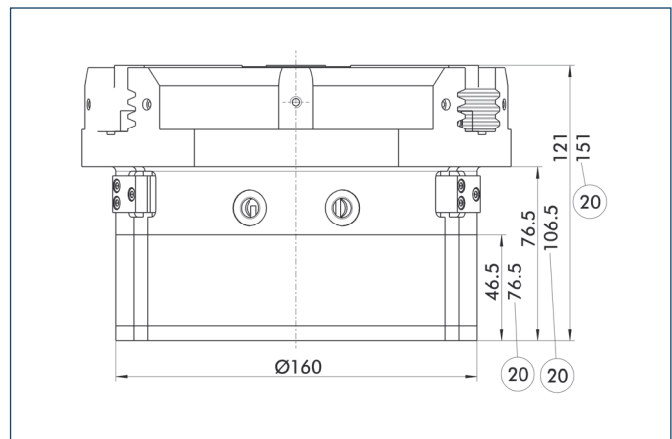

- ⑫ For AS / IS version

The KVZ cylinder increases the gripping forces during opening and closing. A second, in series-connected piston also increases the force on the wedge hook. The full gripping force shown in the data table is sometimes only reached after a few hundred gripping cycles. Please consider that grippers which are equipped with a gripping force maintenance device (AS / IS) are higher.

## Precision version

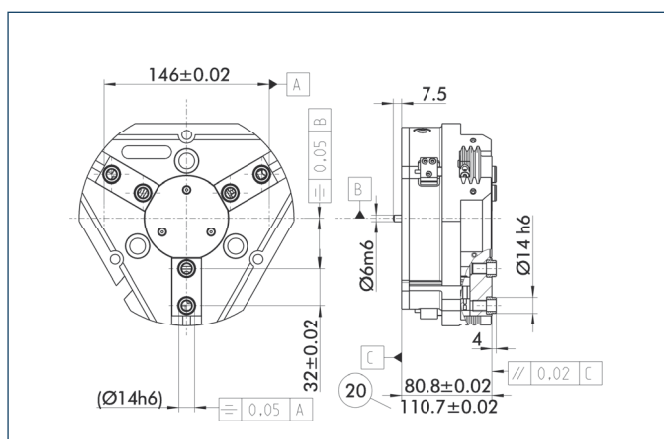

- ⑫ For AS / IS version

The indicated tolerances just refer to the types of precision versions shown in the chart of technical specifications. All other types of precision versions are available on request.

## Spring-loaded pressure piece

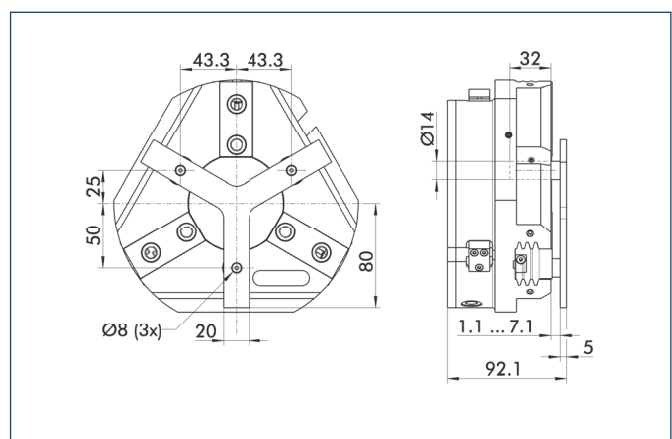

For spring-supported positioning of the workpiece against a stop after the gripper has opened. Especially developed for loading machines.

Description	ID	Stroke	Min. force
Spring-loaded pressure piece			
A-PZN-plus/DPZ-plus 160	0303724	6 mm	205 N

- ⑬ The pressure piece cannot be combined with the dust-protection version. Please contact us if you require a special pressure piece.





# PZN-plus 160

Pneumatic • 3-Finger Centric Gripper • Universal Gripper

## Universal intermediate jaw

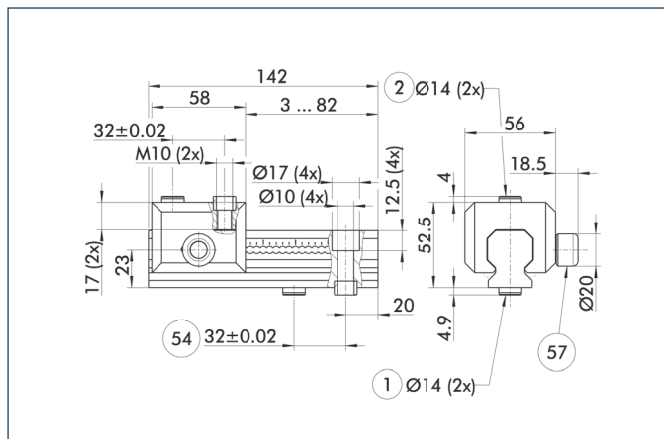

- ① Gripper connection
- ② Finger connection
- ⑤④ Optional right or left connection
- ⑤⑦ Locking

The universal intermediate jaw allows fast tool-free and reliable plugging and shifting of top jaws at the gripper.

Description	ID	Grid dimension
Universal intermediate jaw		
UZB 160	0300046	4 mm
UZB-S 160	5518274	4 mm

- ① The slide UZB-S can be removed completely and has to be ordered separately. Moreover, it allows a fast jaw change.

## Force measuring jaws

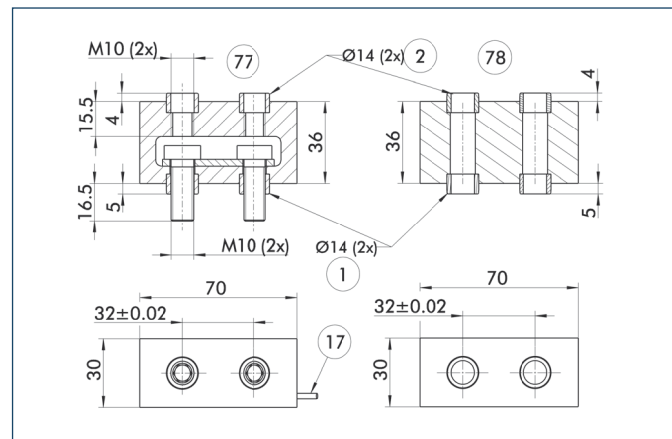

- ① Gripper connection
- ② Finger connection
- ①⑦ Cable outlet
- ⑦⑦ Active intermediate jaws
- ⑦⑧ Passive intermediate jaws

Force measuring jaws measure gripping forces, but can also determine workpiece weights or dimensional deviations. There are active and passive intermediate jaws (FMS-ZBA or FMS-ZBP). At least one active force measuring jaw is required per gripper, the rest can be passive. For each active jaw, a FMS-A1 control unit and a FMS-A connection cable are required.

Description	ID
Active intermediate jaws	
FMS-ZBA 160	0301840
Passive intermediate jaws	
FMS-ZBP 160	0301841
Electronic Processor	
FMS-A2	0301811
Connection cables	
FMS-AK0200	0301820
FMS-AK0500	0301821
FMS-AK1000	0301822
FMS-AK2000	0301823

## Finger blanks

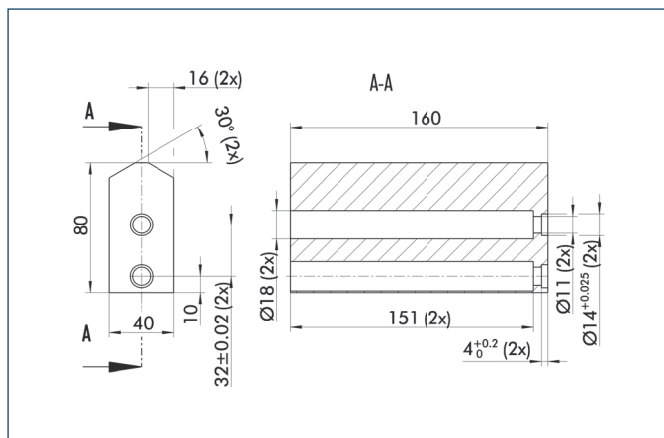

Finger blanks for customized subsequent machining

Description	ID	Material	Scope of delivery
Finger blanks			
ABR-plus 160	0300014	Aluminum	1
SBR-plus 160	0300024	16 MnCr 5	1

You can find more detailed information and individual parts of the above-mentioned accessories in the "Accessories" catalog section.

## Tolerance compensation unit

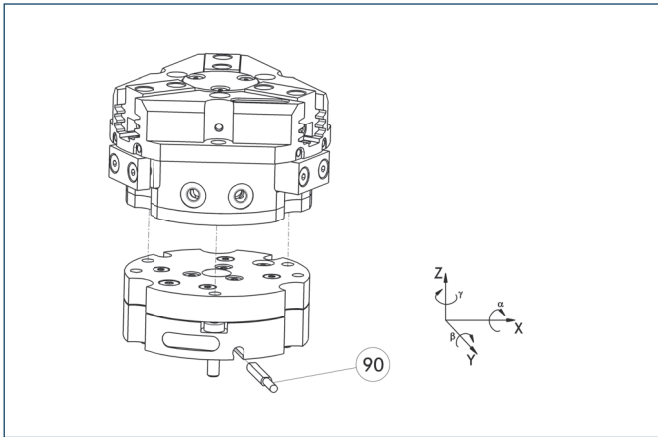

90 Monitoring of locking

Grippers can be directly mounted without an adapter plate. Tolerance compensation unit and gripper have an identical screw connection diagram. Therefore the tolerance compensation units can be assembled later. Please consider the additional assembly height of the tolerance compensation unit. For details see catalog "Robot Accessories".

Description	ID	Locking	Deflection
<b>Compensation unit</b>			
TCU-160-3-MV-Z	0324838	Yes	
TCU-160-3-OV-Z	0324839	No	

## Programmable magnetic switch

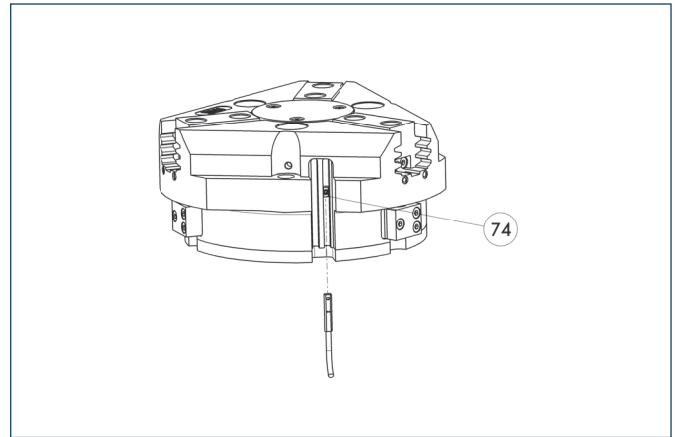

74 Stop for MMS-P

Position monitoring with two programmable positions per sensor. The end position monitoring is mounted in the C-slot.

Description	ID	Recommended product
<b>Programmable magnetic switch</b>		
MMS-P 22-S-M8-PNP	0301370	•
MMSK-P 22-S-PNP	0301371	
<b>Connection cables</b>		
KA BG08-L 4P-0500	0307767	
KA BG08-L 4P-1000	0307768	
KA BW08-L 4P-0500	0307765	
KA BW08-L 4P-1000	0307766	
<b>Sensor Distributor</b>		
V2-M8-4P-2XM8-3P	0301380	

- ① Please note the minimum permitted bending radii for the sensor cables, which are generally 35 mm.
- ① Per gripper one sensor (closer/NO) is required, optionally a cable extension.

## Electronic magnetic switches

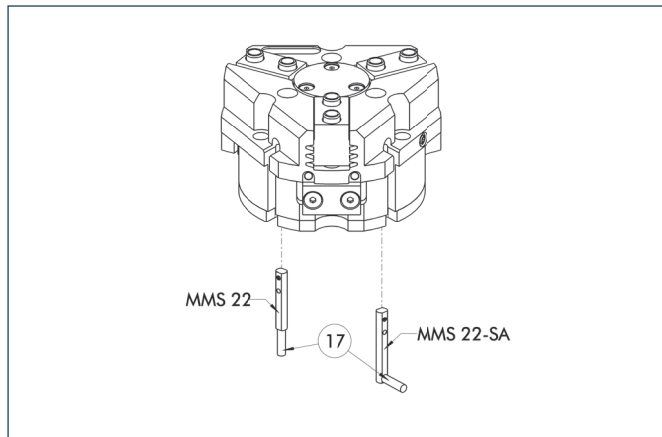

17 Cable outlet

End position monitoring for mounting in the C-slot

Description	ID	Recommended product
<b>Electronic magnetic switches</b>		
MMS 22-S-M5-PNP	0301438	
MMS 22-S-M5-NPN	0301439	
MMS 22-S-M8-PNP	0301432	•
MMS 22-S-M8-NPN	0301433	
MMSK 22-S-PNP	0301434	
MMSK 22-S-NPN	0301435	
<b>Electronic magnetic switches with lateral cable outlet</b>		
MMS 22-S-M5-PNP-SA	0301448	
MMS 22-S-M5-NPN-SA	0301449	
MMS 22-S-M8-PNP-SA	0301442	•
MMS 22-S-M8-NPN-SA	0301443	
MMSK 22-S-PNP-SA	0301444	
MMSK 22-S-NPN-SA	0301445	
<b>Reed Switches</b>		
RMS 22-S-M8	0377720	•
<b>Connection cables</b>		
KA BG05-L 3P-0300	0301652	
KA BG08-L 3P-0300-PNP	0301622	
KA BG08-L 3P-0500-PNP	0301623	
KA BW05-L 3P-0300	0301650	
KA BW08-L 3P-0300-NPN	0301602	
KA BW08-L 3P-0300-PNP	0301594	
KA BW08-L 3P-0500-NPN	9641116	
KA BW08-L 3P-0500-PNP	0301502	
<b>Cable extensions</b>		
KV BW08-SG08 3P-0030-PNP	0301495	
KV BW08-SG08 3P-0100-PNP	0301496	
KV BW08-SG08 3P-0200-PNP	0301497	

① Two sensors (closer/NO) are required for each gripper, plus extension cables as an option.

① Please note the minimum permitted bending radii for the sensor cables, which are generally 35 mm.

## Inductive proximity switches

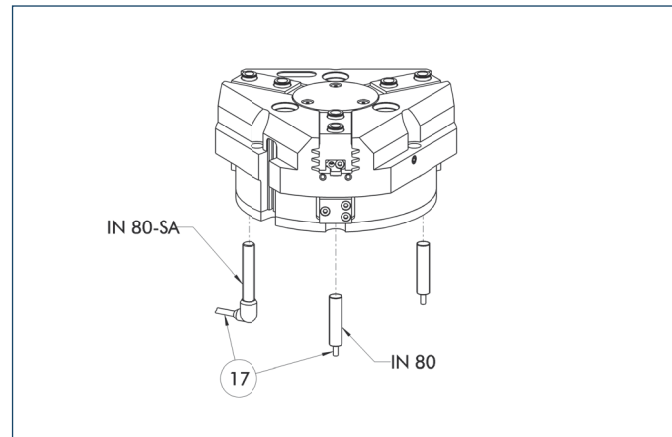

17 Cable outlet

End position monitoring for direct mounting

Description	ID	Recommended product
<b>Inductive proximity switches</b>		
IN 80-S-M8	0301478	•
IN 80-S-M12	0301578	
INK 80-S	0301550	
<b>Inductive proximity switch with lateral outlet</b>		
IN 80-S-M12-SA	0301587	
IN 80-S-M8-SA	0301483	•
INK 80-S-SA	0301566	
<b>Connection cables</b>		
KA BG08-L 3P-0300-PNP	0301622	
KA BG08-L 3P-0500-PNP	0301623	
KA BG12-L 3P-0500-PNP	30016369	
KA BW08-L 3P-0300-PNP	0301594	
KA BW08-L 3P-0500-PNP	0301502	
KA BW12-L 3P-0300-PNP	0301503	
KA BW12-L 3P-0500-PNP	0301507	
<b>Cable extensions</b>		
KV BG12-SG12 3P-0030-PNP	0301999	
KV BG12-SG12 3P-0060-PNP	0301998	
KV BW08-SG08 3P-0030-PNP	0301495	
KV BW08-SG08 3P-0100-PNP	0301496	
KV BW08-SG08 3P-0200-PNP	0301497	
KV BW12-SG12 3P-0030-PNP	0301595	
KV BW12-SG12 3P-0100-PNP	0301596	
KV BW12-SG12 3P-0200-PNP	0301597	

① Two sensors (closer/NO) are required for each gripper, plus extension cables as an option.

① Please note the minimum permitted bending radii for the sensor cables, which are generally 35 mm.

## Cylindrical Reed Switches

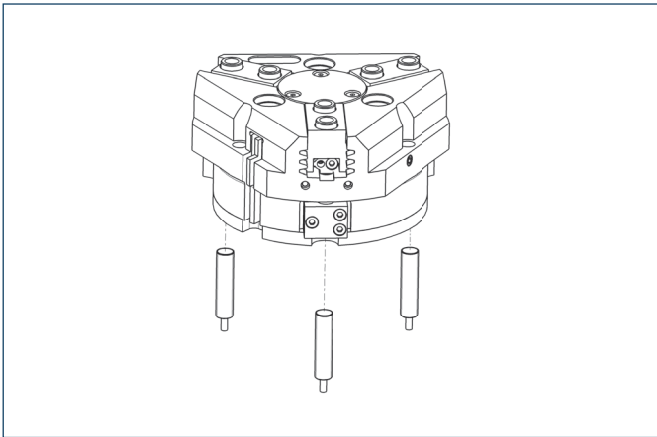

End position monitoring mounted with mounting kit

Description	ID
Mounting kit for proximity switch	
AS-RMS 80 PGN/PZN-plus 160-380	<b>0377727</b>
Reed Switches	
RMS 80-S-M8	<b>0377721</b>

- ① Two sensors (closer/NO) are required for each gripper, plus extension cables as an option.
- ① This mounting kit needs to be ordered optionally as an accessory.
- ① Please note the minimum permitted bending radii for the sensor cables, which are generally 35 mm.

## Analog position sensor

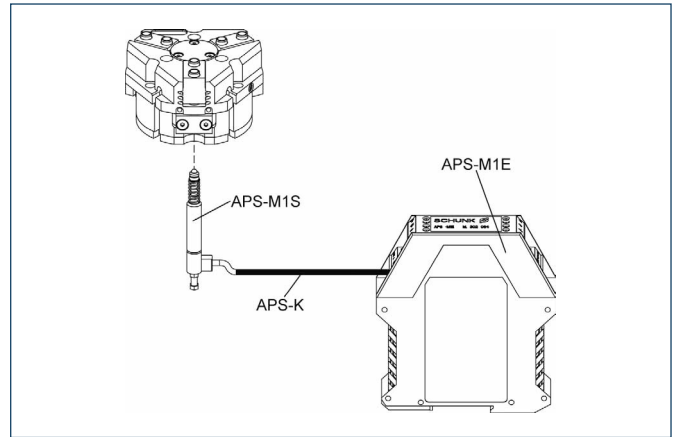

Analog multi position monitoring for any desired positions

Description	ID
Mounting kit	
AS-APS-M1-160/1 and 240/2	<b>0302083</b>
AS-APS-M1-160/2	<b>0302084</b>
Connection cables	
APS-K0200	<b>0302066</b>
APS-K0700	<b>0302068</b>
Electronic Processor	
APS-M1E	<b>0302064</b>
Sensor	
APS-M1S	<b>0302062</b>

- ① When using an APS system, for each gripper a mounting kit (AS-APS), an APS sensor (APS-M1S, incl. 3 m cable) as well as an electronics (APS-M1e) are required.
- ① An extension cable (APS-K) can be connected between the sensor and the electronics as an option. The max. cable length between the sensor and the electronics is 10 m, between the electronics and their control unit (PLC) it is max. 1 m.



You can find more detailed information and individual parts of the above-mentioned accessories in the "Accessories" catalog section.

## Flexible Position Sensor

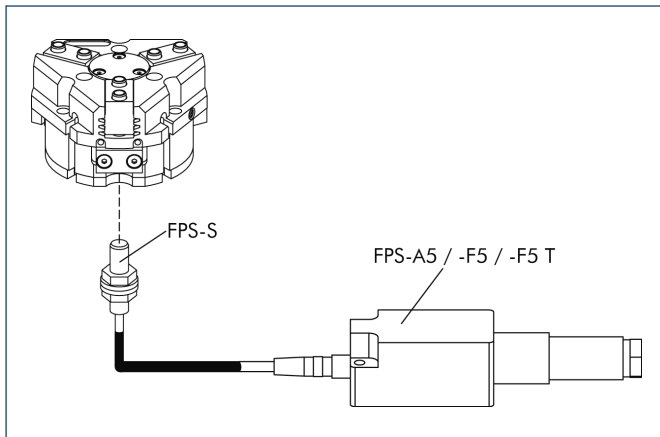

Flexible position monitoring of up to five positions

Description	ID
Mounting kit for FPS	
AS-PGN/PZN-plus 160/1	0301638
AS-PGN/PZN-plus 160/2	0301639
Electronic Processor	
FPS-F5	0301805
FPS-F5 T	0301807
Sensor	
FPS-S M8	0301704

① When using a FPS system, a FPS sensor (FPS-S) and a control unit (FPS-F5 / F5 T or A5) are required for each gripper as well as a mounting kit (AS), if listed. Cable extensions (KV) are available as options in the "Accessories" catalog section.