

PresSpray I

No better airless spray design for die lubrication!

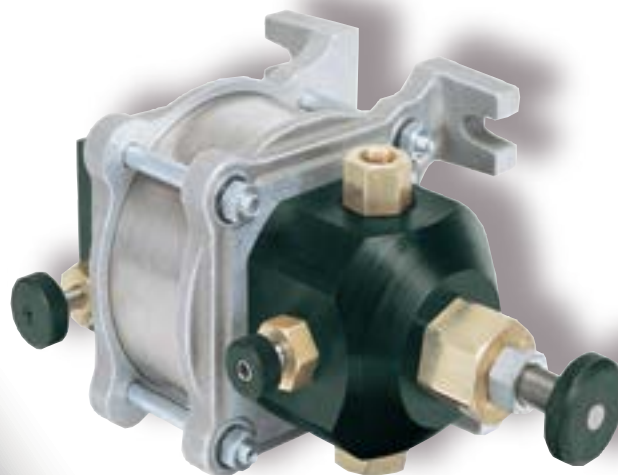

LSP[®]
INDUSTRIES, INC.

The LSP PresSpray Ejector

The PresSpray automatically dispenses a predetermined amount of lubrication in an instantaneous airless spray in unison with the cycle of the press. In an airless spray, the droplets are large and heavy and will not fog the work area.

The PresSpray Ejector draws lubricant into the system and then forcefully ejects it out of the Spray Nozzles in a fine airless spray. Set the desire volume of lubricant needed and that volume will be dispensed on each cycle of the press.

Dies lubricated automatically will run longer, cooler and faster. The operator does not have to worry about die lubrication and can devote his full attention to running the press. The features diagrammed here are standard on all five of our ejectors.

Piston & Ram Assembly

Forces the lubricant out of the nozzle under high pressure to achieve a fine airless spray to evenly coat the work area. To achieve a fine airless spray to evenly coat the work area. The ram is made of ground and polished stainless steel for extended life.

Air Cylinder

Made of honed and polished steel tubing. Nickel plated for wear resistance and corrosion protection.

Mounting Bracket

All units have either a mounting bracket or locations on the end plate castings to accept mounting screws. Mounts to any surface for permanent installations. The MicroSpray mounting bracket can be attached to a MagnaBase for portability.

UniValve

An air valve, specifically sized for each PresSpray model ensures an unrestricted air supply. Located directly behind the piston and ram to deliver air to the PresSpray in the fastest most efficient method possible. A quick exhaust allows for fast recycling.

Velocity Control

Fine tunes the force of the lubricant being sprayed. Eliminates overspray and bounce of very light lubricants. (Not available on the MicroSpray).

Spring Return Piston and Ram

Efficient and economical spring return of the piston & ram replaces costly air return. Saves on air with lightning fast performance.

Gland Fitting

Encapsulates O-rings, separating the lubricant from the air in a brass gland.

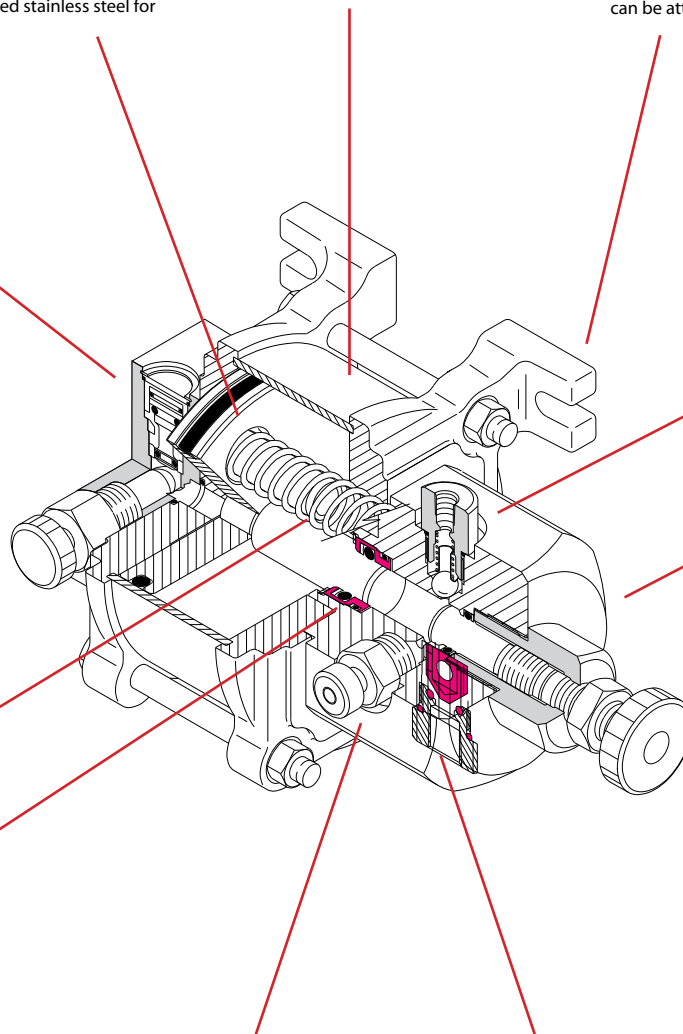

Outlet Port

Holds Outlet Check Valve in place and accepts fittings to allow Manifold to attach direct to the PresSpray or remote from the PresSpray.

Barrel

Handles high pressure portion of Ejector. Fully machined and hard anodized aluminum.

Volume Control

Sets the precise amount of lubricant to be ejected. Simple thumb screw adjustment with finger tightening lock nut.

Bleeder Valve

Affords fast and easy priming of the Ejectors when necessary. The Bleeder Valve Port and Outlet Port are interchangeable if desired.

Inlet Check Valve

Allows immediate recharging of the unit between ejections. Check with ample passage assures a full shot each cycle.

Seals

Chemical resistant Viton O-rings are used throughout the Ejector. Teflon coated Back-Up-Rings are used at all high pressure areas to increase the life of the O-rings.

PresSpray Models

MicroSpray P010-A

This unit dispenses small quantities of lubricants to a single point. It offers the ultimate in low volume control. Because it dispenses only .010 cu. in. at its maximum, the total range is limited, but finely controlled. The MicroSpray gives an ultra fine spray or a single drop upon command.

Includes P232, 95° nozzle and copper or heavy wall nylon tubing for the nozzle.



MiniSpray P040-A

This small and compact unit is able to utilize up to three nozzles at one time depending on the viscosity of the lubricant. When using multiple nozzles, it's capable of lubricating the top and bottom of the stock. Perfect for one or two nozzle applications.

Includes P932, 2 Port Manifold.



MytiSpray P125-B

For the medium size jobs that require heavier lubricants or larger volumes of lubricants. Capable of lubricating the stock before it enters the die, with enough in reserve to lubricate the trouble spots in a die. This unit can spray up to six nozzles. The volume can be reduced to .025 cu. in. without affecting the spray pattern.

Includes P934, 4 Port Manifold.



MegaSpray P135-B

Ideal for large jobs. It can handle up to 15 nozzles when using water soluble lubricants. Lubricate all stations of a progressive die with just one pump. Position nozzles as far as 8 feet from the MegaSpray for long progressive dies.

Includes P934, 4 Port Manifold.



MacroSpray P175-B

An extra large unit for the heavier viscosity lubricants or for larger parts where a greater number of nozzles are needed to accomplish total lubrication. Ideal for automotive plants, appliance plants and other manufacturers of large stampings. Large in volume, high in performance.

Includes P934, 4 Port Manifold.



The PresSpray Ejectors handle a full range of lubricants, with the power to drive heavy viscosity oils, and the controls to govern very light lubricants. From spot lubricating a single tool to covering a large panel, there is a PresSpray Ejector to do the job.

The smallest unit is the MicroSpray and can dispense a single drop as small as .001 cu. in. or break the drop into a fine spray pattern. The MacroSpray is the largest and is normally used on multiple nozzle applications or when using heavier viscosity lubricants. The Mini, Myti and the Mega fall in between the Micro and the Macro in volume, viscosity and capability.

Ejector Specification Chart

Model No.	Volume per Cycle (cu. in.)	Strokes per Minute	Air Consumption per Cycle @80 PSI
P010-A	.000-.010	500	.00070 SCFM
P040-A	.000-.040	450	.00341 SCFM
P125-B	.025-.125	400	.01310 SCFM
P135-B	.075-.375	325	.04714 SCFM
P175-B	.150-.750	250	.10528 SCFM

Oil Viscosities-Number of Nozzles

Model No.	Water Soluble	100 SSU	250 SSU	400 SSU	800 SSU	1200 SSU	2000 SSU	2500 SSU
P010-A	1	1	1	1	N/A	N/A	N/A	N/A
P040-A	4	4	2	2	1	1	N/A	N/A
P125-B	10	8	6	5	3	2	1	N/A
P135-B	20	16	12	10	6	4	3	1
P175-B	20	20	20	20	12	7	3	2

The above chart is a guide and actual results may vary depending upon the tackiness of the lubricant and other variables beyond our control. Tubing lengths greater than six feet may vary performance.

Parts Included with Ejector
Each Ejector, except for the MicroSpray, includes a two or four port Manifold with fittings to either attach to the Ejector or to mount remote from the Ejector. Also included is five feet of 3/8 tubing for installing the Manifold remote from the Ejector.

This is How It Works

The PresSpray Ejector is the HEART of the system. It dispenses lubricant out of the Nozzles with sufficient force to break the lubricant into a fine airless Spray pattern. Determining what options are needed depends on the number of nozzles needed, viscosity of the lubricant, method of actuating it and where the Reservoir is to be located.

Actuators:

The Actuators when tripped send a signal to the PresSpray to dispense fluid. Reference Page 10 and 11 for complete information on all of the Actuator.

Air Timer



Mechanical Actuator



LSP Controller



Manifolds

Manifolds are standard with all units except the MicroSpray. Manifolds can be screwed into the ejector or mounted on the press to offer a clean efficient installation. Fittings are supplied to mount it either way. Manifold as shown below will screw into the fluid outlet.

Bracketed Modules

Includes a PresSpray, FRO and a standard Manifold. Module is installed in a strategic location and supplied with lubricant from a gravity feed reservoir or a diaphragm pump.

Filter, Regulator and oiler

Regulates the air pressure coming from the shop air and adds lubricating oil to protect O-rings and other moving parts.

Module/Reservoir

PresSpray Module is mounted on a Reservoir. Preassembled so that just the Nozzles and the Actuator have to be installed.

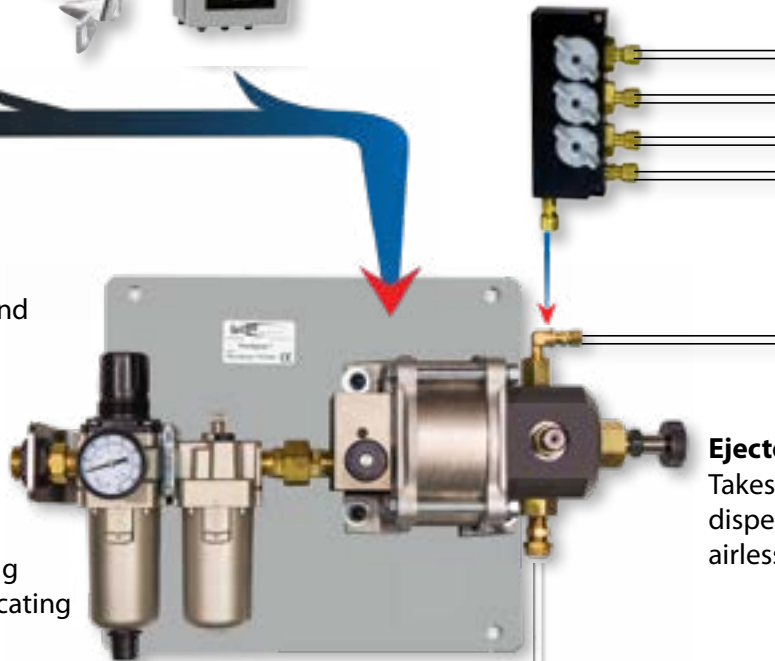

Ejector

Takes lubricant in and then dispenses it in an instantaneous airless spray to the work area.



Diaphragm Pump

Can supply lubricant to the PresSpray from a remote reservoir. Pump is only operational when the PresSpray is cycling. Convenient for larger units.



Nozzle Assemblies

Nozzles are available in different angles and are mounted on a variety of different holders. Nozzles can be attached to manifolds or assembled onto the LSP ExpandaFold Distribution System.

Reference the ExpandaFold Catalog for technical information on the ExpandaFold and the ExpandaValve.

Manifolds

Manifold is mounted remote on the press, offering a clean efficient installation. Just one line from the ejector to the manifold. Multiple fluid lines are dispersed from the manifold to the nozzle



The ExpandaFold

Create a manifold from off the self parts. Each nozzle has its own On/Off ExpandaValve. Choose distance between each nozzle and select pipe to tie ExpandaValves together. This system can be mounted to the ram of the press for a clean efficient installation.

Reference the ExpandaFold brochure for full information

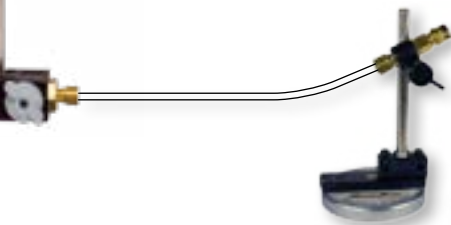

A Rigid Assembly with Flexibility
A nozzle attached to an eleven inch brass tube with a Swivel Bracket that rotates 360°. The swivel bracket allows the assembly to be permanently mounted to a surface or a magnet.

Basic Nozzle and a Swivel Bracket
A compact Basic Nozzle for getting into tight places. Can be mounted on a P925 Swivel Bracket for ease of positioning and can be used with a LSP Magnet for portability or permanently mounted.

MagnaTube
A Flexible Tube with a Nozzle attached to a Magnetic Base for flexibility.

FlexTube Stud Mount
A Flexible Tube with a Nozzle attached to a 1/8 NPTM stud to permanently mount to a surface.

MagnaTube
A Flexible Tube with a Nozzle attached to a Magnetic Base for flexibility.

FlexTube Stud Mount
A Flexible Tube with a Nozzle attached to a 1/8 NPTM to permanently mount to a surface

FlexTube with a Special Adaptor
Allows the FlexTube to be screwed directly into the ExpandaValve.

Basic Nozzle and a Swivel Bracket
A compact Basic Nozzle for getting into tight places. Can be mounted on a P925 Swivel Bracket for ease of positioning and can be used with a LSP Magnet for portability or permanently mounted.

PresSpray Modules

Bracketed Module

A Bracketed Module consists of a PresSpray Ejector and a group of components preassembled on a bracket in a single, compact module. For convenience, the PresSpray attaches to a Bracket that includes an Air Filter/Regulator/Oiler. A two or four port Manifold (the MicroSpray does not have a Manifold) is included with the Module. By installing the Manifolds down stream this greatly makes for a cleaner installation. The Bracketed Module takes most of the work out of installation. The user has only to decide how to interface this system with the Spray Nozzles, Reservoir or PowerPump and what type of Actuator to use.



All the PresSpray Ejectors, from the MicroSpray to the MacroSpray, are available as a Bracketed Module. The two photos show Bracketed Modules being supplied with lubricant from reservoirs and PowerPumps.

Bracketed Modules		
Module No.	Ejector No	Manifold Outlets
P700-A	P010-A	1 Port
P710-A	P040-A	2 Port
P720-B	P125-B	4 Port
P730-B	P135-B	4 Port
P750-B	P175-B	4 Port

Bracketed Modules, with the exception of the P700-A) include Manifold and fittings to install either vertically or horizontal and 6' of tubing for installing the Manifold remote.

A P730-B PresSpray being feed from a 55 gallon drum

For large jobs or long runs it is sometimes convenient to supply lubricant from a large reservoir such as a drum



A MicroSpray Module on a gallon and a half Reservoir.

The MicroSpray lubricating a small press with a single nozzle. The unit is actuated from a LSP Electronic Controller. Since the application needs very little lubricant the controller is set to send a signal on every third cycle of the press.

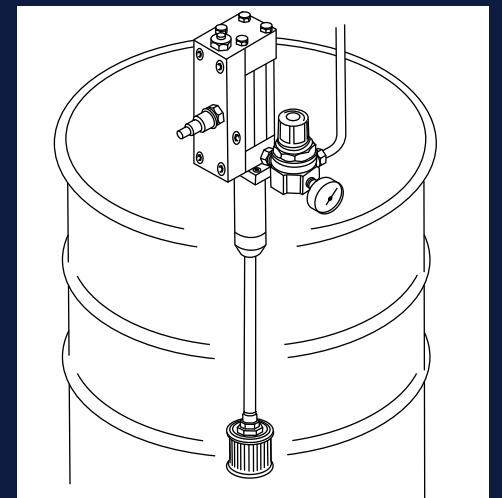

P515 PowerPump

The PowerPump can be used with any size container from a five gallon pail to a 330 gallon tote. Place the inlet hose into the container and attach a hose between the PowerPump outlet and the PresSpray inlet. Turn on the air to the PowerPump and once the system is bled, the PowerPump is ready to supply lubricant upon command. Activate the PresSpray and the PowerPump will automatically replenish any lubricant that has been dispensed by the PresSpray, always keeping it fully charged.

PresSpray Reservoir Modules

Reservoir Modules

Reservoir Modules consist of a Bracketed Module (as shown on page 6) pre-mounted on a Reservoir. The Reservoirs are either free standing or bolted directly to a press. The long chain polyethylene construction stands up to abusive environments. The Modules are available in 1-1/2 gallon, 4 gallon, 8 gallon and 15 gallon reservoirs.

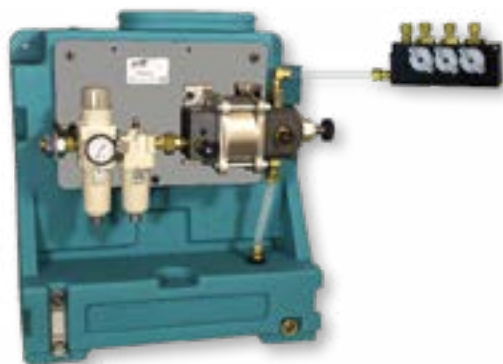

**P735-BC
w/Remote Manifold**
Manifold supplied with 6 feet of tubing and fittings.



**P735-BC
w/attached Manifold**
Manifold attached to the Ejector
*Specify either vertical or horizontal.



**P708A
No Manifold**
For small jobs. Comes with one nozzle and five feet of tubing.

After establishing the Reservoir Module, choose the actuating system and nozzles. Determine if the Manifolds are to be mounted on the Ejector or downstream. Compact and portable, place it where you want and move it from machine to machine when needed. Take it out of the box and it is ready to go to work. *Below are features of the Reservoir Modules.*

Bracketed Modules Mounted on Reservoirs

Systems are available with the Manifolds mounted on the Ejectors or left free for installing on the press or in the die area.

Specify where the Manifold is to be located otherwise it is left unattached for remote installation.

PresSpray Reservoir Modules			
Model No.	Module No.	Manifold	Gallons
P709-AC	P040-A	2 Port	1-1/2
P716-AC	P040-A	2 Port	4
P717-AC	P040-A	2 Port	8
P723-BC	P125-B	4 Port	4
P728-BC	P125-B	4 Port	8
P735-BC	P135-B	4 Port	8
P738-BC	P135-B	4 Port	15
P775-BC	P175-B	4 Port	15

Order necessary components separately

- 1) Type of Nozzles
- 2) Type of Actuator to complete the system.
- 3) P940 Tubing, from manifold to the nozzle

P723-BC PresSpray on a Reservoir with a ExpandaFold Nozzle Assembly
Using the ExpandaFold Nozzle Assembly allows one supply line to handle more than one nozzle. This gives an unobstructed view of the die for the operator while the press is in the run mode.



Creating Nozzle Distribution Systems

The PresSpray offers a variety of ways to locate nozzles in a press to offer maximum spray coverage of the die or stock while allowing for the cleanest installation possible. Locate where the nozzles are to be positioned to determine if the distribution manifold is to be mounted on the PresSpray or down stream on the press.

Manifold Attached to the PresSpray

Two port, four port or larger ExpandaFold manifold can be attached directly to the PresSpray and nozzle extended from there to the work area.

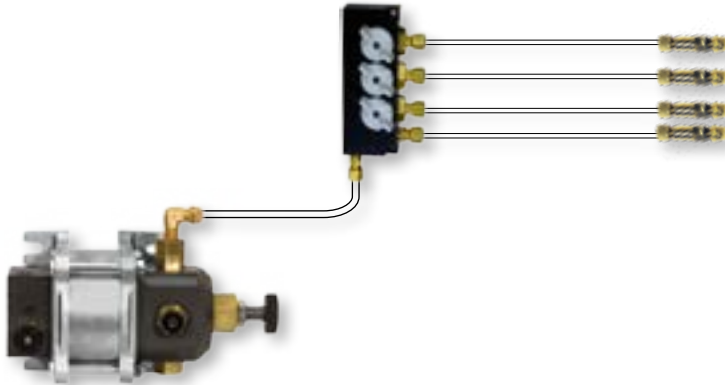
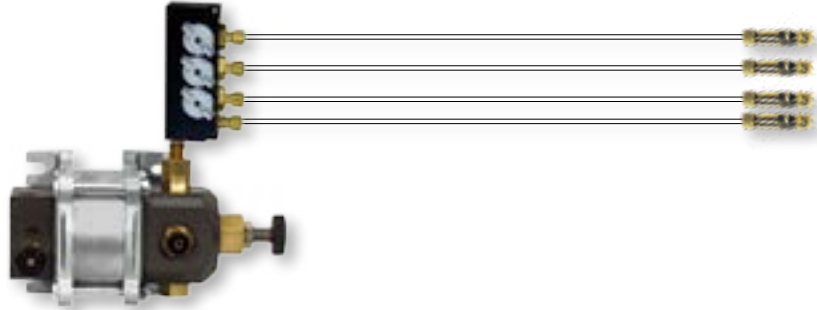

Manifold Remote from the PresSpray

A single manifold either two port, four port or a special ExpandaFold manifold can be attached remote from the PresSpray.

Multiple Remote Manifolds and In-Die Nozzle.

The different ways to layout a PresSpray system is only limited to the imagination. Two Manifolds and an In-Die nozzle complete this system. In-Die nozzle stays with the die for accurate lubrication and speed of setup.

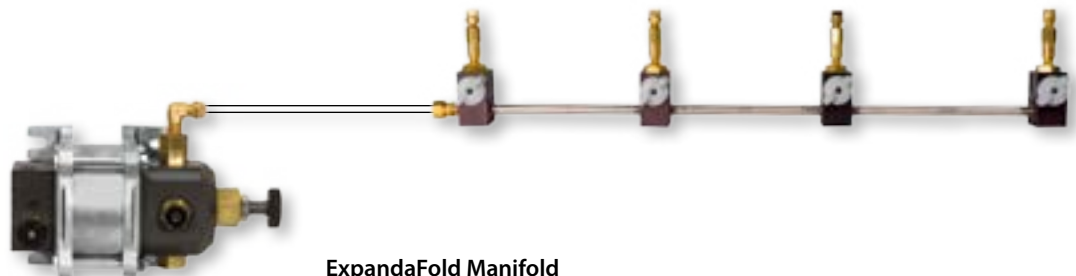
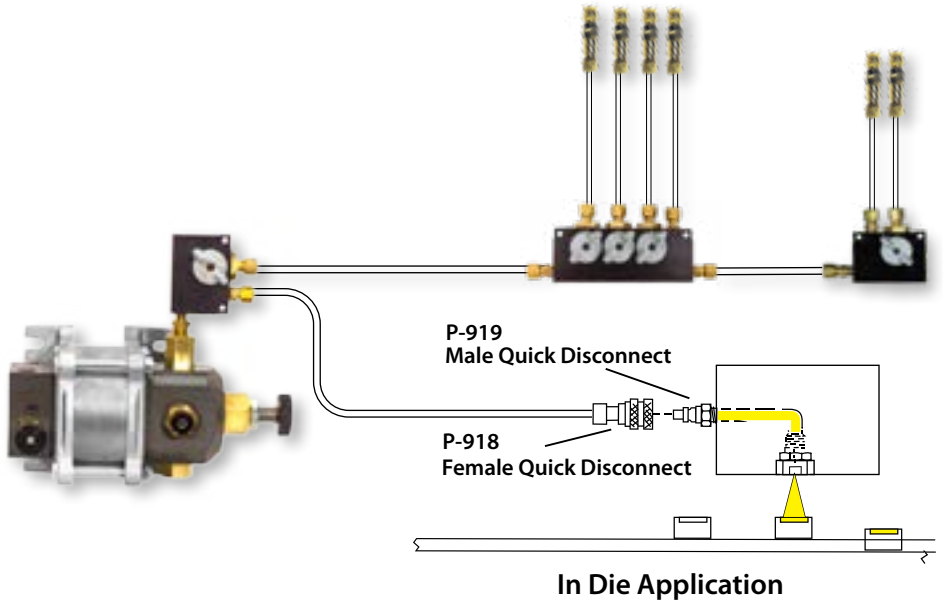

ExpandaFold Manifold

An ExpandaFold with four outlets and four Basic Nozzles is attached remote from the PresSpray. A very clean installation if one wants to mount the nozzles direct to the ram of the press or the lower base of the die.

Nozzles for the PresSpray Systems

A vast variety of Nozzles and Nozzle Accessories are available to individualize every PresSpray application. Choose the Nozzle of choice and Accessories to fit your particular application.



P20X The Basic Nozzles

Available with compression fittings to attach to LSP heavy Wall Tubing or with 1/8NPTM to screw into the P926 nozzle extender. Short lengths make them ideal to fit in close areas. Can be used with the P925 Swivel Bracket for fast positioning of the spray.

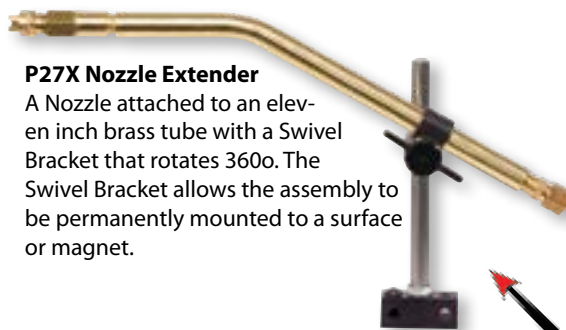

P27X Nozzle Extender

A Nozzle attached to an eleven inch brass tube with a Swivel Bracket that rotates 360°. The Swivel Bracket allows the assembly to be permanently mounted to a surface or magnet.

P925

Swivel Nozzle Bracket
Moves up and down on a 6" rod and rotates 360° for proper positioning of the nozzle.



P25X with 1/8 NPTM

Used with the P926 Nozzle Extender or direct into ExpandaValve.

P905 Magnetic Base

Accepts the P925 Swivel Bracket. It allows for easy placement, positioning or removal of the spray nozzle.



P24X In-Die Nozzle - 1/8 NPTM

Permanently inserted in a die. By having the tool properly positioned the setup time is reduced, production is increased and parts rejected is greatly reduced.

The LSP Quick disconnect allows the tubing supplying the lubricant to be detached from the die to enable die to be removed from the press.



Make the Remote Manifold Portable

To facilitate the installation and portability of Remote Manifolds use the two magnets shown to the right to hold the Manifolds in place on metal surfaces. Simply screw the Manifolds into the Magnet Bracket and set in place.



P904



P907

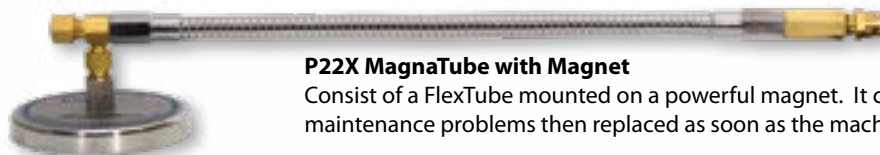

P22X MagnaTube with Magnet

Consist of a FlexTube mounted on a powerful magnet. It can be moved out of the way for setups or maintenance problems then replaced as soon as the machine is ready to go back into production.

P940 LSP High Pressure Tubing

The only non-metal tubing to use for fluid distribution to the nozzles. Other non-metal tubing can give poor spray patterns and after drip.



P21X FlexTube with Stud

A spray nozzle attached to a flexible tube with mounting bracket the other end. The mounting bracket is a 1/8 NPTM that allows permanent installation in a die area.



P926X FlexTube Less the Stud with 1/8 NPTM

A spray nozzle attached to a flexible tube with a 1/8 NPTM at the other end that allows the FlexTube to be screwed directly into a two port, four port or ExpandaValve system.

Type of Nozzle with Check Valve	Type of Spray Pattern				
	110° Fan	80° Fan	65° Fan	25° Fan	55° Fan
Basic Nozzle	P201	P202	P203	P205	P207
FlexTube w/compression Fitting	P211	P212	P213	P215	P217
MagnaTube w/Magnet	P221	P222	P223	P225	P227
In-Die Nozzle	P241	P242	P243	P245	P247
Nozzle with 1/8 NPTM	P251	P252	P253	P255	P257
FlexTube with 1/8 NPTM	P261	P262	P263	P265	P267
Nozzle Extender, Nozzle & Swivel Bracket	P271	P272	P273	P275	P277

Actuators and Controllers

Mechanical and Electronic Options for Activating the System

Three basic Actuators are available for cycling the PresSpray Ejector. The basic Actuators consist of a Mechanical Actuator that triggers when a moving part of the press moves a whisker. Another Actuator is a Solenoid Valve which receives a signal from a limit switch and then activates the PresSpray. A third Actuator is the LSP Air Timer that works on a predetermined time cycle unrelated to the cycle of the press.



P901 Mechanical Actuator with One way Trip Bracket

The Mechanical Actuator is totally air operated and requires no electric input. A One Way Trip Bracket allows actuation of the PresSpray in just one direction of the ram, either up or down. Actuator and Trip Bracket can be mounted to magnetic bases for quick set up.

P912 is 110V and the E230 is 24 V Solenoid Valves

Solenoid Valves allows an electrical signal to actuate the PresSpray. Connect the Solenoid Valve into a programmable controller or to an electrical switch that can energise it when necessary. The PresSpray will cycle immediately when the Solenoid Valve energizes. It mounts directly on the UniValve on the back of the PresSpray or remotely, up to four feet away.



P908 Air Timer/Actuator

Activates the Ejector at repeated time intervals of set length. It divorces the Ejector's operation from the machines cycle and gives it a timed cycle of its own. This accessory has countless applications, one of the most prominent shown below.

Operates from three times per second to once every twenty minutes



Using this motion for this type application can give as good or better lubricant coverage with less consumption of both air and lubricant. Ejecting a larger quantity less often is more efficient and easier to control. The Spray Nozzles are easy to adjust for proper coverage.

Spray Sequence Using the P908 Timer

Timer Application

An Application at a high cycle rate with very short stock progressions usually requires very little lubricant at each cycle. Instead of controlling the operation with a standard Actuator, (ejecting a tiny amount of lubricant at every stroke of the machine) a Timer/Actuator can be used. Larger ejections are applied to lengths of the stock in timed intervals that coincide with the progression of the stock into the machine.

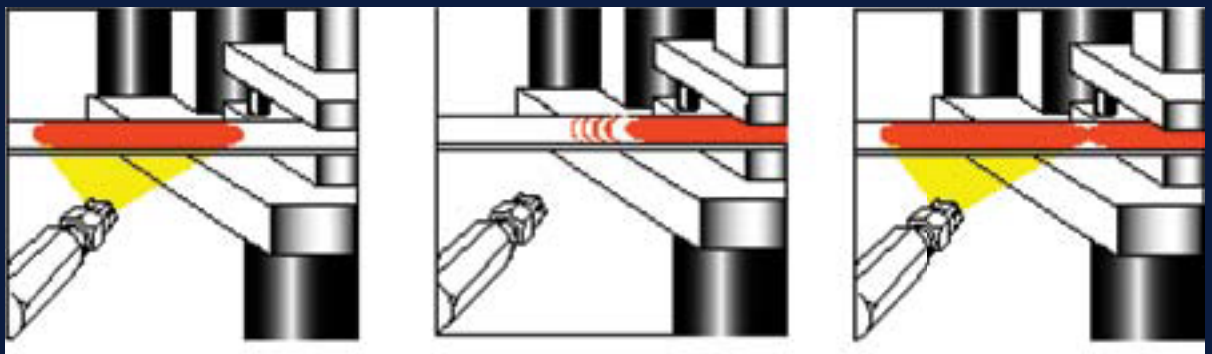

The LSP Industries Electronic Controller

is specifically designed to control the operation of the PresSpray systems. The controller receives a signal from a proximity sensor that captures each cycle of the press and relays that information to the controller. Once the controller receives that information it takes control of the PresSpray and dictates when and how much lubricant it is to dispense lubricant to the die area.



E3000

One Input, one Output

E3002

One Input, two Outputs

Consist of a touch screen computer, solenoid valve, proximity sensor and mounting bracket.

FEATURES

Touch Screen: Visually set the parameters of the program.

Lockout: Prevents unauthorized from changing the program.

Time Delay: Determines how long a delay will transpire before activating the PresSpray after a signal is received.

Pulsator: Gives the PresSpray multiple actuations per cycle of the press.

Counter: Allows the PresSpray to activate on any cycle of the press from 1 - 99.

Memory: Switch to the memory function, assign a number and save.. Recall the number the next time the job is run and the PresSpray is ready for operation. Memory can save up to **99** jobs.

E3015

A TIMER

One Input, one output

Sends repetitive split second signals to actuate the PresSpray. These signals are adjustable from one to ninety nine hours or as fast as 300 per minute. The timer is not tied into each cycle of the press but is tied into the on/off cycle of the press itself. An open ended cord is supplied and is used in place of the sensor. Attach this cord to an external switch that is activated on for as long as the machine is running. When the switch is in the "ON" mode the timer Actuator is on, when the switch is in the "OFF" mode the Time Actuator is de-energized. Also has a memory to save past jobs.

Best applications are high speed presses, roll formers and other similar equipment.

Special Installations

LSP Industries, Inc goes beyond its standard line. When called upon LSP Industries has modified standard products to meet customers requirements. Here we show but a few of the modifications made for our customers.



Four PresSpray Units on a Four Gallon Reservoir
Each PresSpray dispenses fluid when the solenoid that controls it is actuated. An LSP Controller controls when these solenoids actuate.



PresSpray Mounted on a Perforated Screen.
Allows the user to make changes and additions to the system without drilling holes and tapping for mounting screws. Screen is available as a stand alone or with a stand. Wheels are available as an accessory.

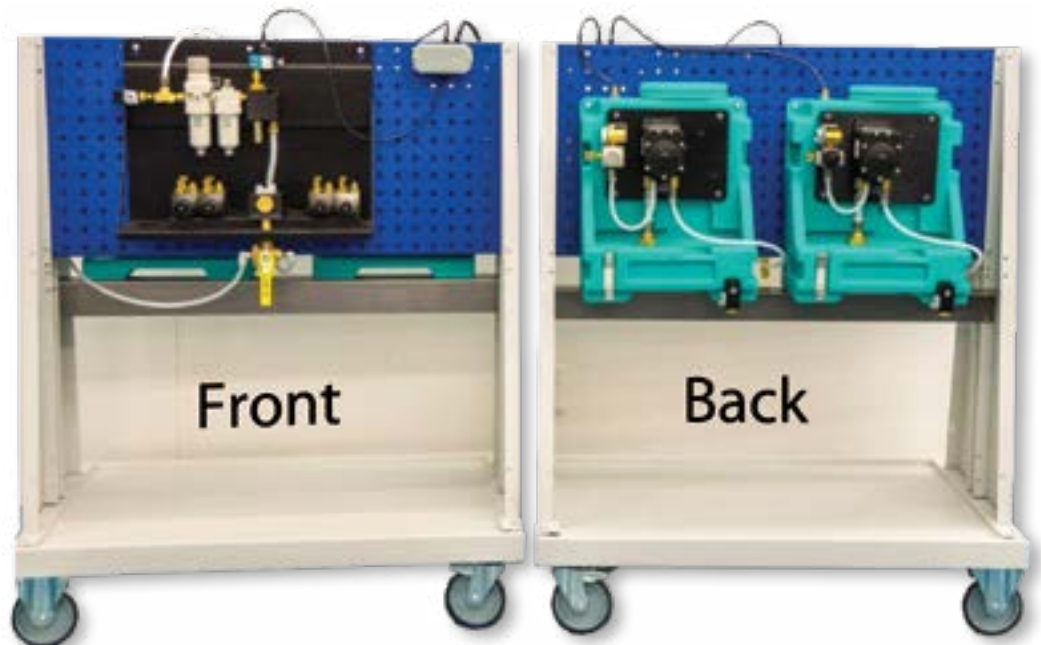

One PresSpray system with two reservoirs mounted on a cart.
The PresSpray is shown in the left picture, which is the front of the cart. Two reservoirs are shown mounted on the backside of the cart. This allows user to switch between different lubricants by just turning a valve under the PresSpray to go from one lubricant to another.

Customize a PresSpray System

The PresSpray Ejector can handle a full range of jobs based on its options setup. LSP Industries, Inc. manufactures a variety of actuators. The P901 Mechanical Actuator is a proven actuator that has been a standard for many years. Electronic actuators give smaller PresSprays the ability to do much larger jobs. They also direct larger PresSprays to actuate in the proper timing sequence, thus conserving lubricant.

Lubricant is supplied from a variety of sources, ranging in size from a one quart container to an eight gallon reservoir. For larger jobs, a PowerPump distributes lubricant from a centrally located container. Here are a few of the systems designed with off the shelf components. A wide variety of nozzles gives users the ability to permanently mount nozzles for quick die change or magnetically mount nozzles for flexibility with die changeover. With all of these options every user can customize a system to fit their particular application.

P125-B MytiSpray

A medium size unit capable of supplying up to six nozzles with water soluble and light to medium viscosity lubricants. Here is the P125-A with a five gallon Reservoir, Manifold, multiple Nozzles and a P912 electric Solenoid Valve. Aim some nozzles at stock going into the die and then place some of the nozzles in the die area where additional lubrication is needed.

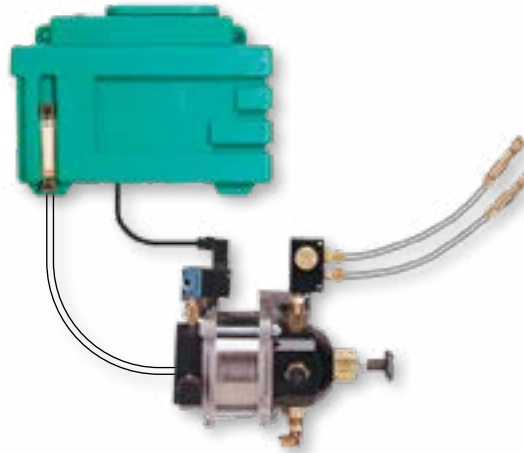

P010-A MicroSpray

A one quart reservoir can last a day or longer when using the MicroSpray. Mount the MicroSpray, Reservoir and Nozzle Assembly on Magnetic bases and it becomes a truly portable unit. Move it to where you want in just seconds. The Micro Spray is being actuated with the P901 Mechanical Actuator on each stroke of the press.



P175-B MacroSpray

In this example the MacroSpray is being supplied with lubricant from a PowerPump mounted on a 55 gallon drum. The nozzles are positioned along a ExpandaFold Manifold attached to the outlet. An E3000 Electronic Controller is activating the PresSpray to give it multiple actuation on each cycle of the press.. This is a perfect system for spraying wide stock as it passes by on its way to the die.

P700-A, P710-A, P720-B, P730-B, P750-B Bracketed Modulares

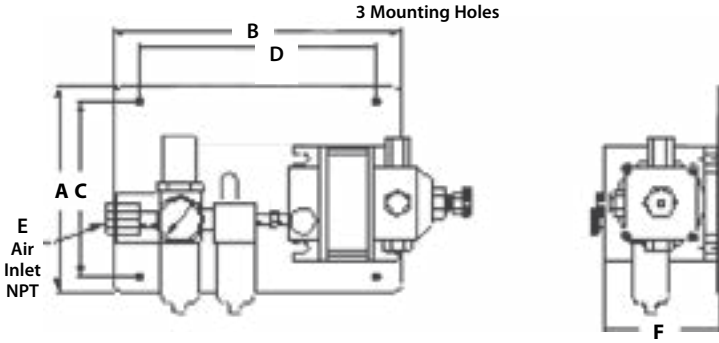

Bracketed Modular Dimensions									
Modular	PresSpray	Manifold	A	B	C	D	E	F	
P700-A	P010-A	1 Port	5.75	7.25	5.00	4.75	1/4 NPT	3.10	
P710-A	P040-A	2 Port	7.50	10.00	6.50	8.50	1/4 NPT	3.10	
P720-B	P-125B	4 Port	7.50	10.00	6.50	8.50	1/4 NPT	4.10	
P730-B	P135-B	4 Port	8.50	13.00	7.50	11.35	3/8 NPT	5.10	
P750-B	P175-B	4 Port	13.00	14.50	11.75	12.50	1/2 NPT	6.10	

E3000, E3002 and E3015

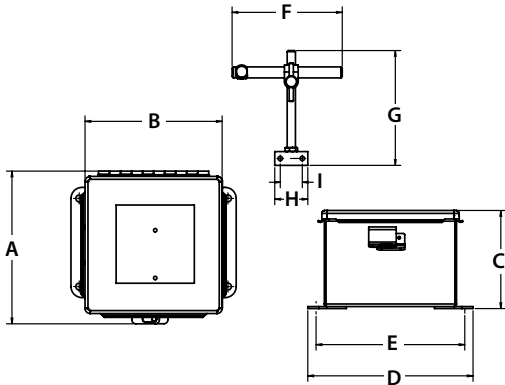

Controller Dimensions									
Model	A	B	C	D	E	F	G	H	I
All	6.931	6.224	4.454	7.500	6.750	5.000	5.213	1.50	1.00

All measurements are in inches

P312-C and P315-C Reservoirs

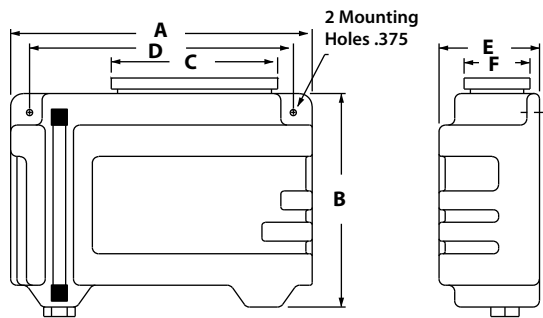

Reservoir Dimensions							
Modular	Gallons	A	B	C	D	E	F
P312-C	1-1/2	12.00	8.50	6.00	10.50	4.125	2.875
P315-C	5	17.50	14.00	7.50	14.00	6.50	3.50

P708-A Reservoir Modular

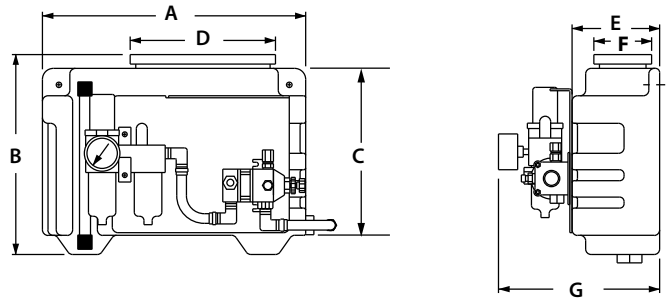

Reservoir Modular Dimensions									
Modular	PresSpray	Gallons	A	B	C	D	E	F	G
P708-AC	P010-A	1-1/2	12.00	8.50	6.50	6.00	4.125	2.875	6.00

P716-AC, P717-AC, P723-BC, P735-BC, P738-BC, P775-BC Reservoir Modulares

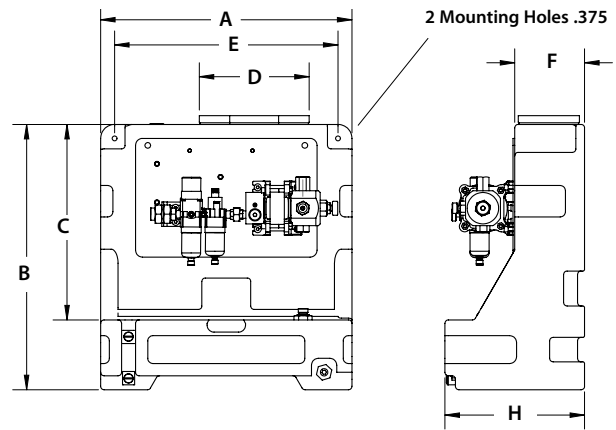

Reservoir Modular Dimensions									
Modular	PresSpray	Gal.	A	B	C	D	E	F	H
P125-B	P040-A	4	14.00	16.00	11.50	4.375	12.50	4.50	8.75
P723-AC	P040-A	8	18.00	19.00	14.00	4.875	16.00	5.00	9.25
P728-BC	P-125B	4	14.00	16.00	11.50	4.375	12.50	4.50	8.75
P730-BC	P125-B	8	18.00	19.00	14.00	4.875	16.00	5.00	9.25
P735-BC	P135-B	8	18.00	19.00	14.00	4.875	16.00	5.00	9.25
P738-BC	P135-B	8	18.00	19.00	14.00	4.875	16.00	5.00	9.25
P775-BC	P175-B	15	20.25	22.50	14.50	11.50	N/A	6.75	11.50

PresSpray Nozzles

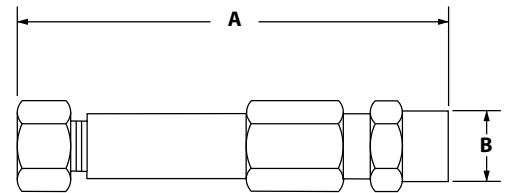

Nozzle Dimensions				
Part #	Model	Fluid Inlet	A	B
P20X	Basic Nozzles	1/4 Tube	2.375	.50
P25X	Basic Nozzles NPT	1/8 NPT	3.00	.50
P21X	FlexTube	1/4 Tube	12.00	.50
P22X	MagnaTube	1/4 Tube	12.00	.50
P23X	MicroSpray Nozzles	3/16 Tube	2.375	.50

Specifications

P010-A MicroSpray

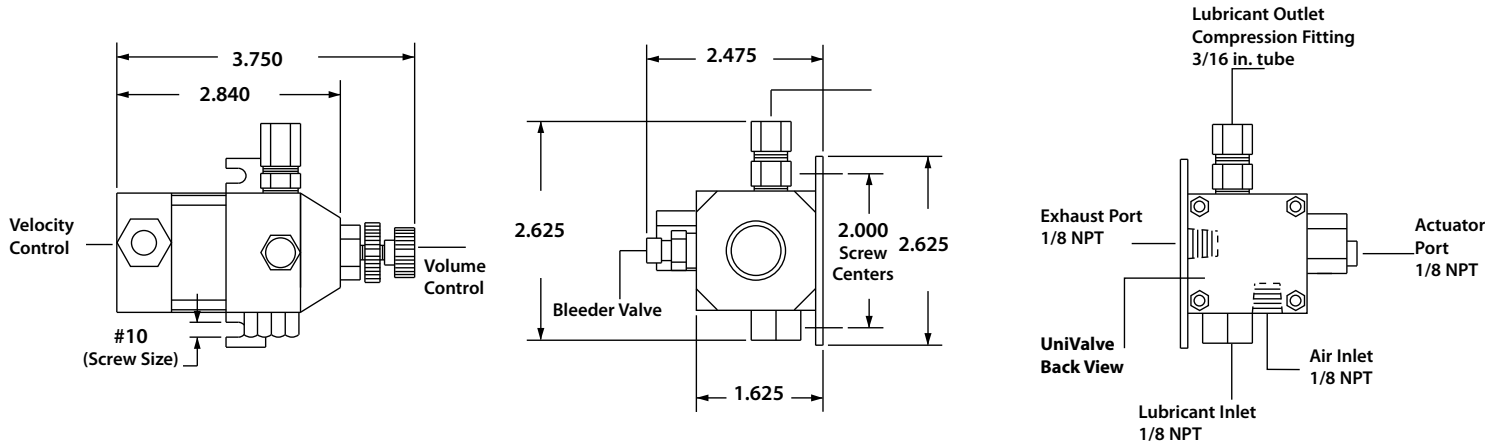

P040-A MiniSpray

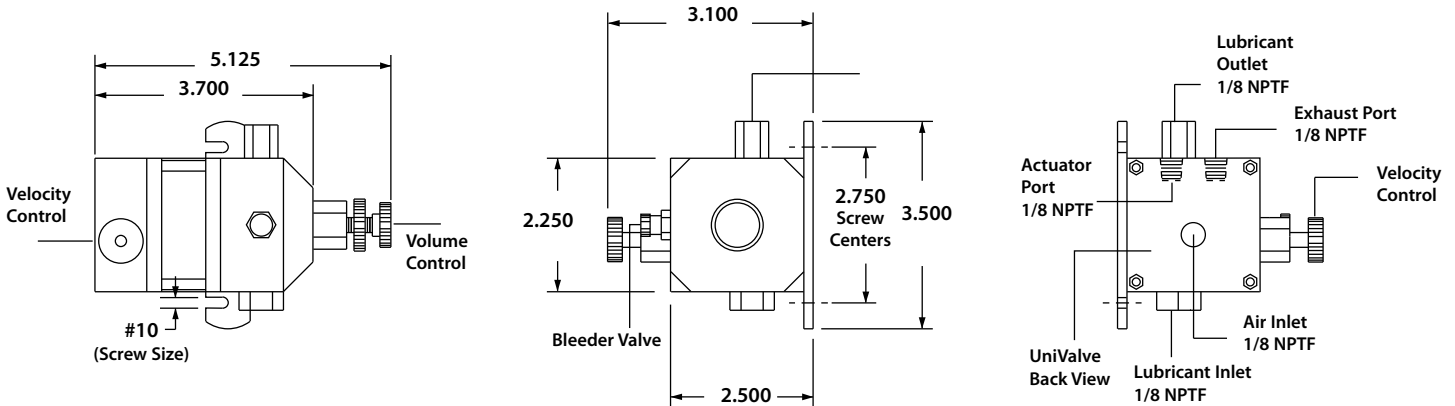

P125-B, P135-B and P175-B PresSprays

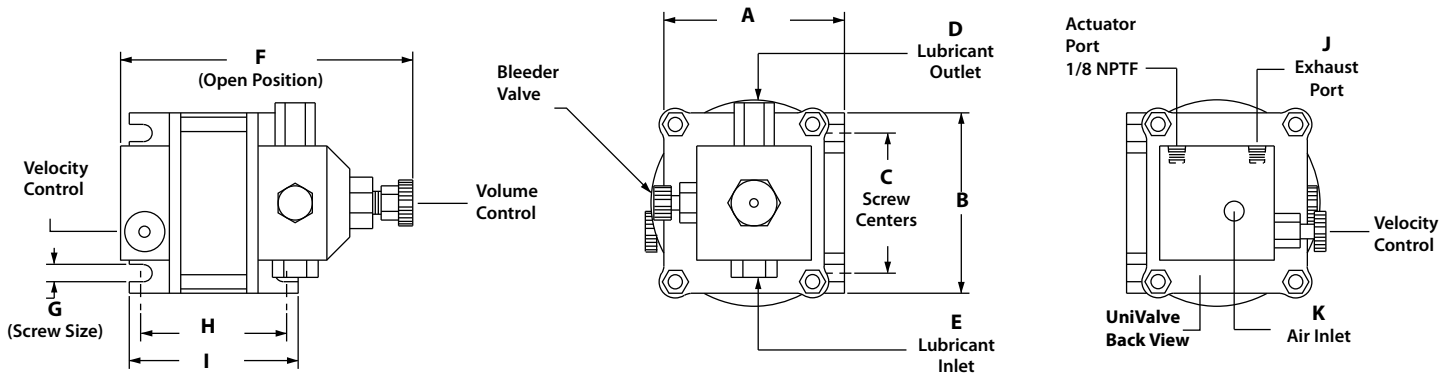

PresSpray Ejector Dimensions.

Model	Manifold	A	B	C	D	E	F	G	H	I	J	K
P125-B	4 Port	4.00	4.10	3.062	1/4 NPTF	1/4 NPTF	6.70	.312	2.932	3.50	1/4 NPTF	1/4 NPTF
P135-B	4 Port	5.50	5.00	3.75	1/4 NPTF	3/8 NPTF	9.50	.375	4.50	4.875	3/8 NPTF	3/8 NPTF
P175-B	4 Port	6.00	6.00	4.612	1/4 NPTF	3/8 NPTF	10.825	.375	4.825	5.875	3/8 NPTF	1/2 NPTF

Accessories



P312-C 1-1/2 gallon Reservoir P315-C 5 gallon Reservoir

Reservoirs include four feet of Outlet Tubing to connect to PresSpray Ejectors. A sight gage provides instant indication of fluid level and a lubricant filter prevents contaminants from entering the system.

P-301 1 quart Reservoir for MicroSpray P-305 1 quart Reservoir with Magnetic Base

Includes four feet of outlet tubing to connect to MicroSpray Units.



ExpandaValves

ExpandaValves tied together with tie rods create a compact manifold. Reference the ExpandaFold catalog for applications to create unique manifolds.



P930 PortaPlatform

Mount the PresSpray on a 15 gallon reservoir attached to the PortaPlatform for mobility.

Level Controls	
100 Series	Reservoir Size (Gal.)
E150	1-1/2
E152	5
E155	4
E158	8
E165	15

100 Series Level Control

Activates a light when the lubricant level is low. Can also be tied in to shut off a machine.

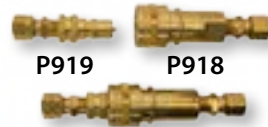

Quick Disconnect

Quick Disconnects attach nozzles to the PresSpray manifolds. Allows leaving nozzles with dies when stamping is done. New die with nozzles attached can be plugged into the manifold for a fast startup.



FC7310 Diaphragm Pump

Supplies Fluid to PresSpray units under 40 - 60 PSI. One pump is capable of supplying lubricant to multiple PresSprays.

Fluid Outlet Tubing		
Cat. No.	Tube Size (OD)	Fluid Tubing
P940	1/4"	Nylon (for all Ejectors except MicroSpray)
P943	3/16"	Nylon (MicroSpray Only)
P948	1/4"	Copper (for all other Ejectors)
P949	3/16"	Copper (MicroSpray Only)
P950	3/8"	High Pressure Nylon

Airline Fittings			
Cat. No.	Pipe Thread	Tube (OD) to Ejectors	For Air Connection
P951	1/8"	1/4"	P010-A - P040-A
P953	1/4"	3/8"	P125-B
P955	3/8"	1/2"	P135-B
P960	1/2"	3/4"	P175-B

Air Line Tubing		
Cat. No.	Tube Size (OD)	Air Tubing for
P942	1/4"	P010-A - P040-A
P944	3/8"	P125-B
P946	1/2"	P135-B & P175-B
M902	3/16"	For Actuator Tube



P.O. Box 5303, 61125 | 5060 - 27TH AVE., 61109 | ROCKFORD, IL
TEL: 815-226-8090 | FAX: 912-226-9250 | E-MAIL: SALES@LSPIND.COM

WEB: WWW.LSPIND.COM