



YOUR CYLINDER SOURCE

Quality Cylinders: Pneumatic & Hydraulic

HISTORY OF YATES INDUSTRIES



HISTORY

Yates Industries was founded in 1972 as a fluid power products distributor and repair facility. Working with the automotive industry and steel mills in the Great Lakes area, the requests for quality pneumatic and hydraulic cylinders spawned the creation of the Yates Cylinder division. From the early days of design and production through today's high-tech marketplace, we have strived to be the standard by which our competitors are judged. With hundreds of dedicated distributors around the globe, Yates Cylinders is your cylinder source. From heavy duty hydraulic to light duty aluminum, we have the answer for your fluid power application.

CUSTOMER SERVICE

Yates Cylinders is known for world class customer service, we understand the needs of the manufacturing community. As experienced professionals, we will do everything in our power to get your product right, and delivered on time, every time. With our 24 hour emergency service, we are on call to help you when you need us.



QUALITY

Yates Cylinders is an ISO 9001:2000 registered company. With quality control as a main priority, we proudly offer one of the industries leading warranties at 3 full years. We can do this because we use only the finest materials and the most experienced production staff. Yates cylinders have proven to be the most reliable and cost effective cylinders available today.



MACHINING

Our extensive machining department includes multiple boring mills, CNC machines, 11 manual lathes and radial arm drills. This allows us to control the whole process from receipt of order to shipment of product without relying on outside sources. This also allows us to offer our expedited delivery, sometimes shipping product the same day.



FACILITY

With our state of the art manufacturing facility, we can build your cylinders faster and with better quality than our competition. With over 100,000 square feet of production area, we are capable of handling small jobs on a rush basis up to your largest production runs.

RAW MATERIALS

We don't just say "24 hour service." Yates Cylinders' huge inventory of tubing, rod stock, cold rolled bar, and seals gives us the ability to manufacture product without delays.



TESTING

As an integral part of our quality process, all cylinders are thoroughly tested to their rated pressures before being shipped. With test stands rated for 10,000 PSI and fixtures for special applications such as water service, be assured your product is ready for use when you receive it.



TABLE OF CONTENTS:

Series "H6" Heavy Duty Hydraulic	5
H6 features	6
H6 mounting styles	7
H6 how to order information	8
H6 mounting dimensions	10-33
H6 mounting accessories	34-36
H6 optional rod end styles	37
Series "H4/A4/L4" Medium Duty Hyd./Steel Air/Permanently Lubricated	39
H4/A4/L4 features	40
H4/A4/L4 mounting styles	41
How to order information	43
Mounting dimensions	44-71
Mounting accessories	74-76
Optional rod end styles	77
Series "A2/H2" Aluminum Air Service/ Light Duty Hydraulic	79
A2/H2 features	80
Mounting styles	81
Mounting dimensions	84-100
Optional rod end styles	101
Mounting accessories	102-104
Engineering Section	105
Selecting the cylinder	106
Stop tube and Rod Diameter Selection	107
Types of cylinders	108
Adjustable Stroke Cylinders	110
Proximity switch information	111
Reed and Hall Effect Switch information	112
Linear Displacement Transducer information	114
Yates Air Oil Tanks	116
Cylinder rod boot information and ordering information	118
Cylinder Sealing options/ Mounting considerations	120
Corrosive resistant cylinder options	121
Yates YRL series rod locks	122
Yates YS series round body cylinders	124-125
Yates Industries YS-Mil mill cylinders	126-127
Yates Industries Repair and Maintenance information	129
Yates Industries Terms and Conditions	138



WARNING IMPROPER SELECTION, IMPROPER USE OR FAILURE OF THE PRODUCTS AND/OR SYSTEMS DESCRIBED HEREIN CAN CAUSE PROPERTY DAMAGE, PERSONAL INJURY AND/OR DEATH.

The information contained herein and other information from Yates Industries Inc. provides product and/or system information for further investigation by users having expertise. It is the sole responsibility of the end user to analyze all aspects of your application and any consequences of any failure and to review the information about the product or system in the current catalog. Based on the vast amount of applications and operating conditions it is the sole responsibility of the end user, through its own testing and analysis, for making the final decision as to product selection and assuring all performance, safety and warning requirements of the application are met.

Based on our continued effort to improve our products we reserve the right to make engineering changes without advance notice.

HEAVY DUTY HYDRAULIC

Series H6

3000 PSI RATED



Air-Oil Systems

airoil.com

H6 FEATURES

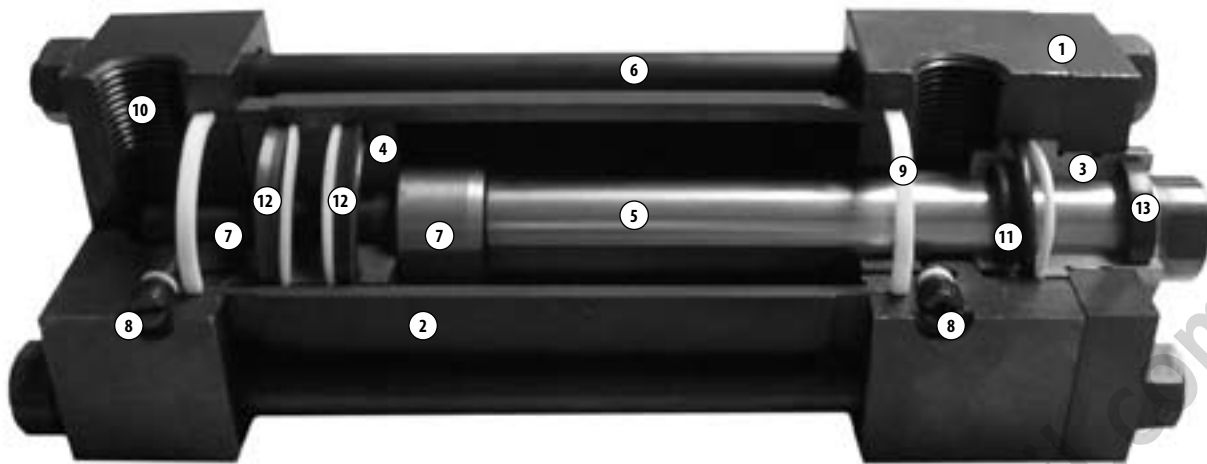

- 1. HEAD/CAP-** Precision machined steel head and cap provide close concentricity and accurate alignment between piston, tube, piston rod and rod bearing.
- 2. CYLINDER BARREL-** Damage resistant, heavy wall steel tubing, honed to an 8 to 16 micro finish for low frictional drag and maximum seal and piston bearing life.
- 3. ROD CARTRIDGE-** Extra long, high strength bronze gland provides maximum bearing support and wear resistance. With certain exceptions a removable retainer allows for gland removal without cylinder disassembly.
- 4. PISTON-** One piece fine grained cast iron piston provides maximum strength and protection against shock loads. Anaerobic adhesive is used to permanently lock and seal the piston to the rod.
- 5. PISTON ROD-** High strength damage resistant piston rod provides 100,000 PSI minimum yield material in 5/8" through 4 1/2" diameters. Larger diameters vary between 50,000 and 75,000 PSI minimum material. All rods are case hardened to 50-55 RC and hard chrome plated to provide maximum wear life. Stainless steel is also available.
- 6. TIE RODS-** 100,000 to 125,000 PSI minimum yield steel, pre-stressed for fatigue resistance, and roll threaded for added strength.
- 7. CUSHIONS-** Head cushion sleeve and rear cushion spear are machined to close tolerances to provide a gradual deceleration and reduced shock at end of stroke.
- 8. CUSHION NEEDLE ADJUSTMENT AND BALL CHECK-** Flush mounted captive cushion adjustment allows for safe cushion adjustment under pressure. Special tip design and fine threads allow for precise adjustment over a broad range of operations. Cushion ball check allows for fast break away under full power.
- 9. TUBE END SEALS-** Extrusion resistant Teflon[®] material is compatible with virtually all fluids and can operate in temperatures to 500°F.
- 10. PORTS-** NPT ports are standard and can be rotated to any 90 degree position in relation to each other and the mounting. SAE ports are optional at no extra charge.
- 11. ROD SEAL-** Twin lip urethane rod seal is pressure energized and wear compensating for long, leak-free service. Viton[®] seals are optional.
- 12. PISTON SEALS-** Pressure energized nitrile U-cups, with Teflon[®] back-up rings are standard. Step cut cast iron rings and Viton[®] seals are optional.
- 13. ROD WIPER-** Nitrile double lip rod wiper acts as a secondary seal while keeping dirt, dust and other contaminants out. Optional Viton[®] wiper is available for fluid compatibility or temperatures to 400°F. Metallic scrapers and low friction wipers are also available.

SIDE MOUNTS

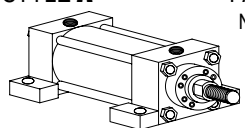
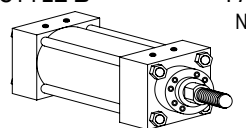
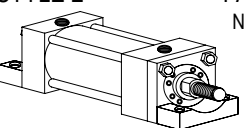
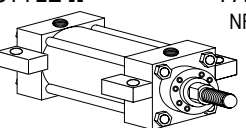
<p>STYLE A PAGE 10 NFPA-MS2</p>  <p>SIDE LUGS 1 1/2-8" BORE</p>	<p>STYLE B PAGE 10 NFPA-MS4</p>  <p>SIDE TAPPED 1 1/2-8" BORE</p>	<p>STYLE E PAGE 12 NFPA-MS7</p>  <p>SIDE END LUGS 1 1/2-8" BORE</p>	<p>STYLE H PAGE 10 NFPA-MS3</p>  <p>CENTER-LINE LUGS 1 1/2-8" BORE</p>
--	--	---	---

END MOUNTS

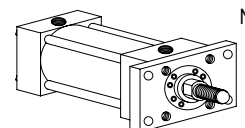
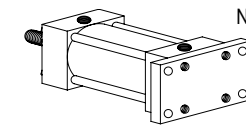
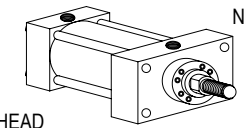
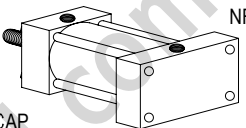
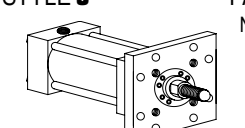
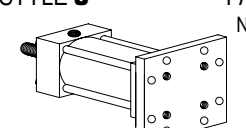
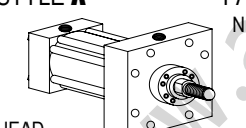
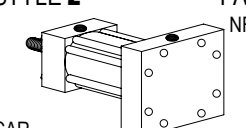
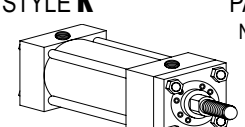
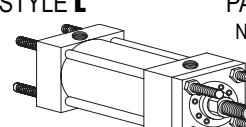
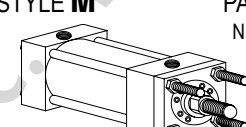
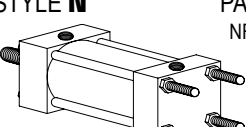
<p>STYLE F PAGE 24 NFPA-MF1</p>  <p>HEAD RECTANGULAR FLANGE 1 1/2-8" BORE</p>	<p>STYLE R PAGE 24 NFPA-MF2</p>  <p>CAP RECTANGULAR FLANGE 1 1/2-8" BORE</p>	<p>STYLE G PAGE 26 NFPA-ME5</p>  <p>HEAD RECTANGULAR INTEGRAL FLANGE 1 1/2-14" BORE</p>	<p>STYLE P PAGE 26 NFPA-ME6</p>  <p>CAP RECTANGULAR INTEGRAL FLANGE 1 1/2-14" BORE</p>
<p>STYLE J PAGE 24 NFPA-MF5</p>  <p>HEAD SQUARE FLANGE 1 1/2-8" BORE</p>	<p>STYLE S PAGE 24 NFPA-MF6</p>  <p>CAP SQUARE FLANGE 1 1/2-8" BORE</p>	<p>STYLE X PAGE 28 NFPA-ME3</p>  <p>HEAD SQUARE INTEGRAL FLANGE 10-20" BORE</p>	<p>STYLE Z PAGE 28 NFPA-ME4</p>  <p>CAP SQUARE INTEGRAL FLANGE 10-20" BORE</p>
<p>STYLE K PAGE 30 NFPA-MX0</p>  <p>NO TIE RODS EXTENDED 1 1/2-20" BORE</p>	<p>STYLE L PAGE 30 NFPA-MX1</p>  <p>BOTH ENDS TIE RODS EXTENDED 1 1/2-8" BORE</p>	<p>STYLE M PAGE 30 NFPA-MX3</p>  <p>HEAD TIE RODS EXTENDED 1 1/2-8" BORE</p>	<p>STYLE N PAGE 30 NFPA-MX2</p>  <p>CAP TIE RODS EXTENDED 1 1/2-8" BORE</p>

PIVOT MOUNTS – CLEVIS AND TRUNNION

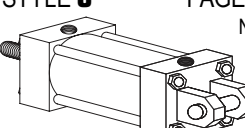
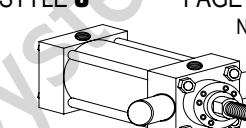
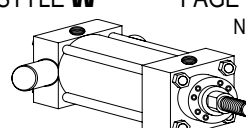
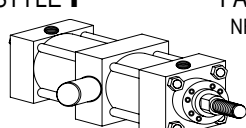
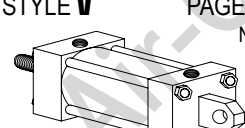
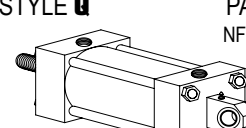
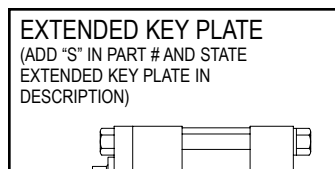
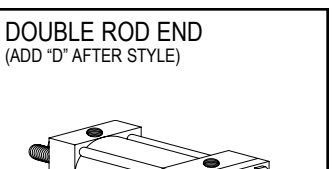
<p>STYLE C PAGE 16-19 NFPA-MP1</p>  <p>FIXED CLEVIS 1 1/2-20" BORE</p>	<p>STYLE U PAGE 20-23 NFPA-MT1</p>  <p>HEAD TRUNNION 1 1/2-20" BORE</p>	<p>STYLE W PAGE 20-23 NFPA-MT2</p>  <p>CAP TRUNNION 1 1/2-20" BORE</p>	<p>STYLE T PAGE 20 NFPA-MT4</p>  <p>INTERMEDIATE FIXED TRUNNION 1 1/2-8" BORE</p>
<p>STYLE V PAGE 16-19 NFPA-MP3</p>  <p>CAP FIXED EYE 1 1/2-14" BORE</p>	<p>STYLE Q PAGE 14 NFPA-MPU3</p>  <p>SPHERICAL BEARING 1 1/2-6" BORE</p>	<p>EXTENDED KEY PLATE (ADD "S" IN PART # AND STATE EXTENDED KEY PLATE IN DESCRIPTION)</p>  <p>1 1/2-8" BORE PAGE 32</p> <p>DOUBLE ROD END (ADD "D" AFTER STYLE)</p>  <p>1 1/2-20" BORE PAGE 32</p>	

YATES HEAVY DUTY HYDRAULIC CYLINDERS ARE DESIGNED TO ACCEPT YATES STANDARD MOUNTING ACCESSORIES. SEE PAGES 34-36



PRESSURE RATINGS

CYLINDER BORE (INCHES)	PISTON ROD DIAMETER (INCHES)			PRESSURE RATINGS (PSI)	
	STANDARD	OVERSIZE	2:1	HEAVY-DUTY SERVICE	4:1 SAFETY FACTOR
1 1/2	5/8		1	3000 *	2000
2	1		1 3/8	3000 *	2000
2 1/2	1	1 3/8	1 3/4	3000 *	1950
3 1/4	1 3/8	1 3/4	2	3000 *	2100
4	1 3/4	2	2 1/2	3000 *	1900
5	2	2 1/2, 3	3 1/2	3000 *	1900
6	2 1/2	3, 3 1/2	4	3000 *	2000
7	3	3 1/2, 4, 4 1/2	5	3000 *	1850
8	3 1/2	4, 4 1/2, 5	5 1/2	3000 *	1900
10	4 1/2	5, 5 1/2	7	3000 *	
12	5 1/2	7	8	3000 *	
14	7	8, 9	10	3000 *	
16	8	9, 10		3000 *	
18	9	10		3000 *	
20	10			3000 *	

* PRESSURE FOR "F" AND "R" MOUNTS IS LOWER SEE PAGE 24

Φ 4:1 SAFETY FACTOR BASED ON FAILURE PRESSURES OF WEAKEST COMPONENT AND STANDARD ROD SIZE

FOR HIGHER PRESSURES CONSULT FACTORY

H6 RETAINER INFORMATION

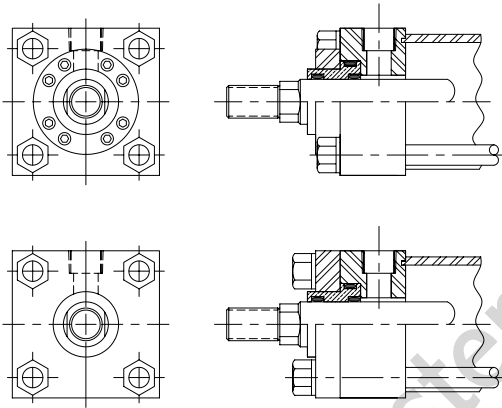

H6 cylinders with the following bore and rod combinations use circular retainers which permit removal of rod cartridge without disassembling cylinder.

- 2 1/2" bore with 1" rod
- 3 1/4" bore with 1 3/8" rod
- 4" thru 20" bores with all rod diameters

H6 cylinders with the following bore and rod combinations use full plate retainer construction.

- 1 1/2" bore with 5/8" and 1" rods
- 2" bore with 1" and 1 3/8" rods
- 2 1/2" bore with 1 3/8" and 1 3/4" rods
- 3 1/4" bore with 1 3/4" and 2" rods

LARGE BORE TIE ROD INFORMATION

On large bore cylinders, two or three tie rods are used at each corner of the 10, 12, 14, 16, 18 and 20 inch bore sizes. This reduces flexing of head and cap under pressure.

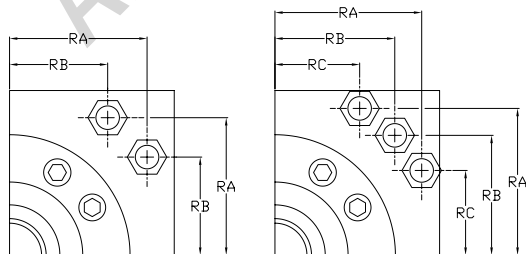

BORE	RA	RB	RC	TIE ROD
10	5.291	3.775	NA	1 1/8-12
12	6.27	4.555	NA	1 1/4-12
14	7.485	6.143	4.409	1 1/4-12
16	8.086	6.093	NA	1 1/2-12
18	9.589	7.91	5.761	1 1/2-12
20	10.437	8.75	6.649	1 1/2-12

HOW TO ORDER H6 CYLINDERS

Feature	Description	Page #	Symbol	H	6	A	D	N	3	.	2	N	-	4	8	.	2	5	S	1	.	3	8	T	2	S	1	1		
Series	Heavy Duty Hydraulic		H6																											
Mounting Style	Side lugs (MS2)	10	A																											
	Side tapped (MS4)	10	B																											
	Side end lugs (MS7)	12	E																											
	Center-line lugs (MS3)	10	H																											
	Head rectangular flange (MF1)	24	F																											
	Cap rectangular flange (MF2)	24	R																											
	Head square flange (MF5)	24	J																											
	Cap square flange (MF6)	24	S																											
	Head rectangular integral flange (ME5)	26	G																											
	Cap rectangular integral flange (ME6)	26	P																											
	Head square integral flange (ME3)	28	X																											
	Cap square integral flange (ME4)	28	Z																											
	No tie rods extended (MX0)	30	K																											
	Both ends tie rods extended (MX1)	30	L																											
	Head tie rods extended (MX3)	30	M																											
	Cap tie rods extended (MX2)	30	N																											
	Cap clevis (MP1)	16-19	C																											
	Cap eye (MP3)	16-19	V																											
	Spherical bearing (MPU3)	14	Q																											
Head trunnion (MT1)	20-23	U																												
Cap trunnion (MT2)	20-23	W																												
Intermediate fixed trunnion (MT4)	20	T																												
Double Rod	Double rod design if needed		D																											
Cushions	No cushions		N																											
	Cushion head end only		R																											
	Cushion cap end only		C																											
	Cushioned both ends		B																											
Bore size	Specify in inches																													
Piston seals	Nitrile U-cups		N																											
	Cast iron rings		C																											
	Poly seals		P																											
	Viton® seals		V																											
	Fluorocarbon poly seals		F																											
	Other (Specify)		X																											
Stroke	Specify in inches with 2 place decimal																													
Ports	NPTF		N																											
	SAE		S																											
	Welded coupler		W																											
	Other (Specify)		X																											
Rod dia.	Specify in inches																													
Rod Seals	Twin lip hydraulic seal (standard)		T																											
	Poly seals		P																											
	Viton® seals		V																											
	Fluorocarbon poly seals		F																											
	Other (Specify)		X																											
	Rod End	Standard male		2																										
	Standard female		4																											
	Intermediate male		1																											
	Long female		3																											
	Extended standard male		5																											
	Extended intermediate male		6																											
	Plain rod end		7																											
	Male full thread		8																											
	Male rod coupling		9																											
	Special male (specify)		M																											
	Special female (specify)		F																											
	Special stud (specify)		S																											
	Special other (specify)		X																											
Specials Specify	High load piston		S																											
	Stop tube																													
	Proximity switches																													
	Non-standard mount																													
	Stainless steel rod																													
	Extra rod extension																													
	Many more options available																													
Head port	specify location 1-4		1-4																											
Cap port	specify location 1-5		1-5																											



SIDE LUGS MOUNT

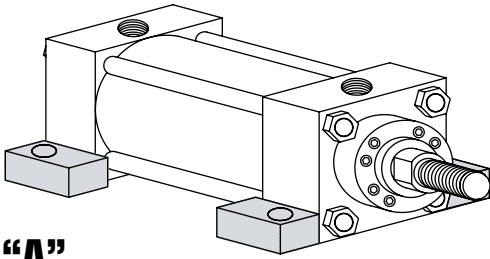

“A”
YATES STYLE A
NFPA-MS2

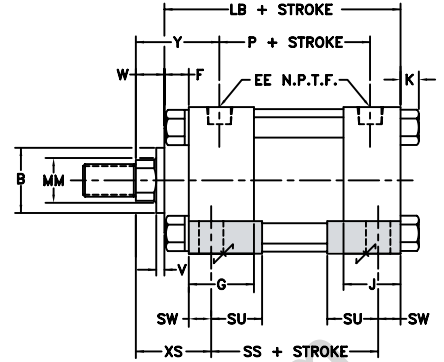
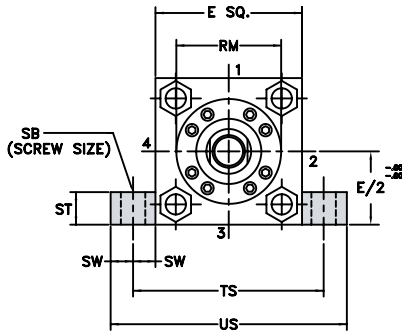

SIDE TAPPED MOUNT

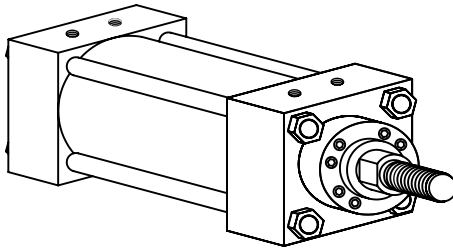

“B”
YATES STYLE B
NFPA-MS4

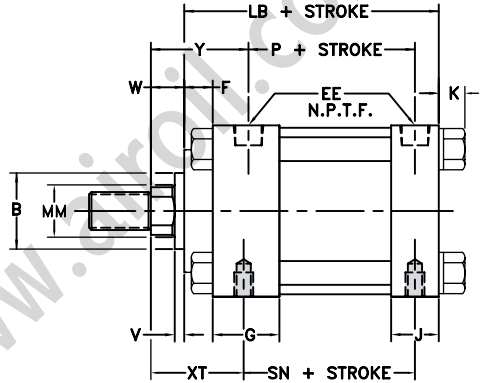
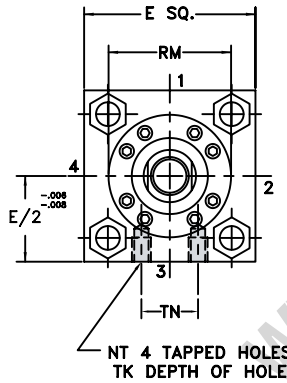

CENTER-LINE LUGS MOUNT

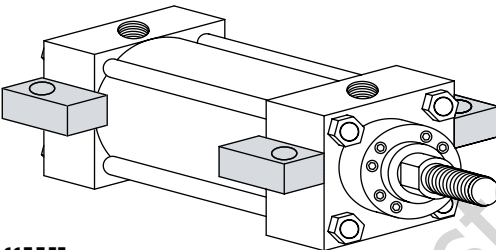

“H”
YATES STYLE H
NFPA-MS3

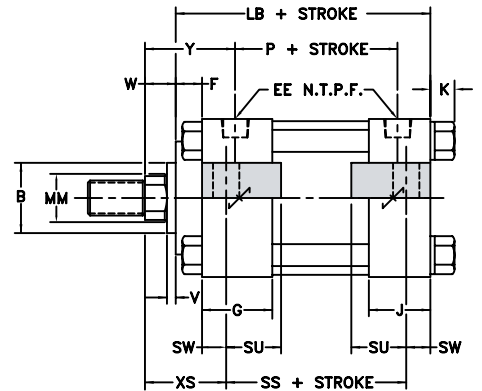
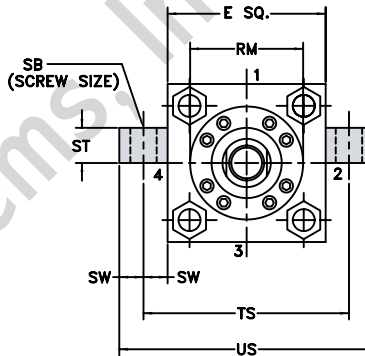

- † HEAD END PORTS SHALLOW TAPPED
- CONSULT FACTORY FOR AVAILABILITY OF SAE PORT OPTION
- Δ (4) SPANNER HOLES USED INSTEAD OF FLATS ON 4" DIA. AND LARGER RODS
- § THESE CYLINDERS HAVE FULL PLATE RETAINERS. USE "E" DIMENSION INSTEAD OF "RM" - SEE PAGE 8
- ‡ B DIMENSION TOLERANCE -.001 / -.003
- * SS DIMENSION CHANGES ON DOUBLE ROD CYLINDERS - SEE PAGE 33 FOR DETAILS
- NOTE:** SUGGESTED THAT THESE MOUNTS BE KEYPED OR PINNED TO PREVENT SHIFTING
- ⊕ CONSULT FACTORY FOR DIMENSIONS.

STANDARD ROD ENDS

#2 STD MALE
NFPA-SM

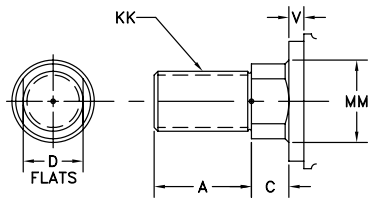

#4 STD FEMALE
NFPA-SF

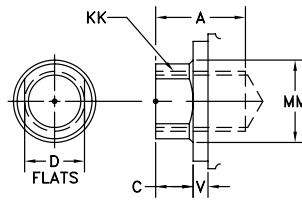

#1 MALE
NFPA-IM

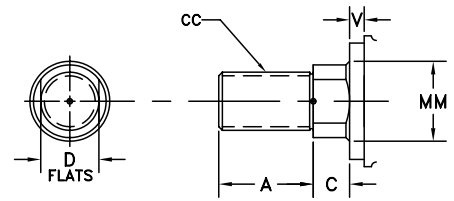

BORE	SAE															ADD STROKE			
	E	EE	OPT.	F	G	J	K	NT	SB	ST	SU	SW	TN	TS	US	LB	P	SN	SS*
1 1/2	2 1/2	1/2	10	3/8	1 3/4	1 1/2	3/8	3/8-16	3/8	1/2	15/16	3/8	3/4	3 1/4	4	5	3	2 7/8	3 7/8
2	3	1/2	10	5/8	1 3/4	1 1/2	7/16	1/2-13	1/2	3/4	1 1/4	1/2	15/16	4	5	5 1/4	3	2 7/8	3 5/8
2 1/2	3 1/2	1/2	10	5/8	1 3/4	1 1/2	7/16	5/8-11	3/4	1	1 9/16	11/16	1 5/16	4 7/8	6 1/4	5 3/8	3 1/8	3	3 3/8
3 1/4	4 1/2	3/4	12	3/4	2	1 3/4	9/16	3/4-10	3/4	1	1 9/16	11/16	1 1/2	5 7/8	7 1/4	6 1/4	3 5/8	3 1/2	4 1/8
4	5	3/4	12	7/8	2	1 3/4	9/16	1-8	1	1 1/4	2	7/8	2 1/16	6 3/4	8 1/2	6 5/8	3 7/8	3 3/4	4
5	6 1/2	3/4	12	7/8	2	1 3/4	3/4	1-8	1	1 1/4	2	7/8	2 15/16	8 1/4	10	7 1/8	4 3/8	4 1/4	4 1/2
6	7 1/2	1	16	1	2 1/4	2 1/4	7/8	1 1/4-7	1 1/4	1 1/2	2 1/2	1 1/8	3 5/16	9 3/4	12	8 3/8	5	5 1/8	5 1/8
7	8 1/2	1 1/4	20	1	2 3/4	2 3/4	1	1 1/2-6	1 1/2	1 3/4	2 7/8	1 3/8	3 3/4	11 1/4	14	9 1/2	5 1/2	5 7/8	5 3/4
8	9 1/2	1 1/2	24	1	3	3	1 1/16	1 1/2-6	1 1/2	1 3/4	2 7/8	1 3/8	4 1/4	12 1/4	15	10 1/2	6 1/4	6 5/8	6 3/4

BORE	ROD DIA. MM	THREAD		ROD EXTENSIONS AND PILOT DIMENSIONS									ENVELOPE AND MOUNTING DIMENSIONS		
		KK	CC	A	B ±	C	D	V	W	TK	RM	XS	XT	Y	
1 1/2	5/8	7/16-20	1/2-20	3/4	1 1/8	3/8	1/2	1/4	5/8	9/16	§	1 3/8	2	1 15/16	
	1 †	3/4-16	7/8-14	1 1/8	1 1/2	1/2	7/8	1/2	1	Φ	§	1 3/4	Φ	2 5/16	
2	1	3/4-16	7/8-14	1 1/8	1 1/2	1/2	7/8	1/4	3/4	1/2	§	1 7/8	2 3/8	2 5/16	
	1 3/8 †	1-14	1 1/4-12	1 5/8	2	5/8	1 1/8	3/8	1	Φ	§	2 1/8	Φ	2 9/16	
2 1/2	1	3/4-16	7/8-14	1 1/8	1 1/2	1/2	7/8	1/4	3/4	13/16	2 5/8	2 1/16	2 3/8	2 5/16	
	1 3/8 †	1-14	1 1/4-12	1 5/8	2	5/8	1 1/8	3/8	1	Φ	§	2 5/16	Φ	2 9/16	
	1 3/4 †	1 1/4-12	1 1/2-12	2	2 3/8	3/4	1 1/2	1/2	1 1/4	Φ	§	2 9/16	Φ	2 13/16	
3 1/4	1 3/8	1-14	1 1/4-12	1 5/8	2	5/8	1 1/8	1/4	7/8	3/4	3 7/32	2 5/16	2 3/4	2 11/16	
	1 3/4	1 1/4-12	1 1/2-12	2	2 3/8	3/4	1 1/2	3/8	1 1/8	3/4	§	2 9/16	3	2 15/16	
4	2 †	1 1/2-12	1 3/4-12	2 1/4	2 5/8	7/8	1 3/4	3/8	1 1/4	Φ	§	2 11/16	Φ	3 1/16	
	1 3/4	1 1/4-12	1 1/2-12	2	2 3/8	3/4	1 1/2	1/4	1	1	3 7/8	2 3/4	3	2 15/16	
	2	1 1/2-12	1 3/4-12	2 1/4	2 5/8	7/8	1 3/4	1/4	1 1/8	Φ	4	2 7/8	Φ	3 1/16	
	2 1/2	1 7/8-12	2 1/4-12	3	3 1/8	1	2 1/8	3/8	1 3/8	Φ	4 7/16	3 1/8	Φ	3 5/16	
5	2	1 1/2-12	1 3/4-12	2 1/4	2 5/8	7/8	1 3/4	1/4	1 1/8	1 1/8	4	2 7/8	3 1/8	3 1/16	
	2 1/2	1 7/8-12	2 1/4-12	3	3 1/8	1	2 1/8	3/8	1 3/8	1 1/8	4 7/16	3 1/8	3 3/8	3 5/16	
	3	2 1/4-12	2 3/4-12	3 1/2	3 3/4	1	2 5/8	3/8	1 3/8	1 1/8	5 1/4	3 1/8	3 3/8	3 5/16	
	3 1/2	2 1/2-12	3 1/4-12	3 1/2	4 1/4	1	3	3/8	1 3/8	Φ	5 5/8	3 1/8	Φ	3 5/16	
6	2 1/2	1 7/8-12	2 1/4-12	3	3 1/8	1	2 1/8	1/4	1 1/4	1 5/16	4 7/16	3 3/8	3 1/2	3 7/16	
	3	2 1/4-12	2 3/4-12	3 1/2	3 3/4	1	2 5/8	1/4	1 1/4	1 5/16	5 1/4	3 3/8	3 1/2	3 7/16	
	3 1/2	2 1/2-12	3 1/4-12	3 1/2	4 1/4	1	3	1/4	1 1/4	1 5/16	5 5/8	3 3/8	3 1/2	3 7/16	
	4	3-12	3 3/4-12	4	4 3/4	1	Δ	1/4	1 1/4	Φ	6 7/16	3 3/8	Φ	3 7/16	
7	3	2 1/4-12	2 3/4-12	3 1/2	3 3/4	1	2 5/8	1/4	1 1/4	1 1/8	5 1/4	3 5/8	3 13/16	3 3/4	
	3 1/2	2 1/2-12	3 1/4-12	3 1/2	4 1/4	1	3	1/4	1 1/4	1 1/8	5 5/8	3 5/8	3 13/16	3 3/4	
	4	3-12	3 3/4-12	4	4 3/4	1	Δ	1/4	1 1/4	1 1/8	6 7/16	3 5/8	3 13/16	3 3/4	
	4 1/2	3 1/4-12	4 1/4-12	4 1/2	5 1/4	1	Δ	1/4	1 1/4	Φ	7 1/8	3 5/8	Φ	3 3/4	
	5	3 1/2-12	4 3/4-12	5	5 3/4	1	Δ	1/4	1 1/4	Φ	7 5/8	3 5/8	Φ	3 3/4	
8	3 1/2	2 1/2-12	3 1/4-12	3 1/2	4 1/4	1	3	1/4	1 1/4	1 9/16	5 5/8	3 5/8	3 15/16	3 7/8	
	4	3-12	3 3/4-12	4	4 3/4	1	Δ	1/4	1 1/4	1 9/16	6 7/16	3 5/8	3 15/16	3 7/8	
	4 1/2	3 1/4-12	4 1/4-12	4 1/2	5 1/4	1	Δ	1/4	1 1/4	1 9/16	7 1/8	3 5/8	3 15/16	3 7/8	
	5	3 1/2-12	4 3/4-12	5	5 3/4	1	Δ	1/4	1 1/4	1 9/16	7 5/8	3 5/8	3 15/16	3 7/8	
	5 1/2	4-12	5 1/4-12	5 1/2	6 1/4	1	Δ	1/4	1 1/4	Φ	8 3/8	3 5/8	Φ	3 7/8	



SIDE END LUGS MOUNT

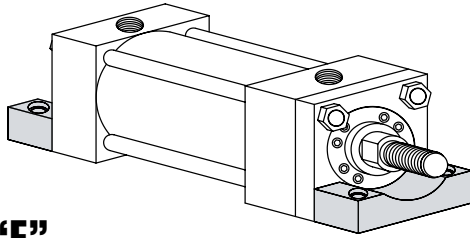

“E”
YATES STYLE E
NFPA-MS7

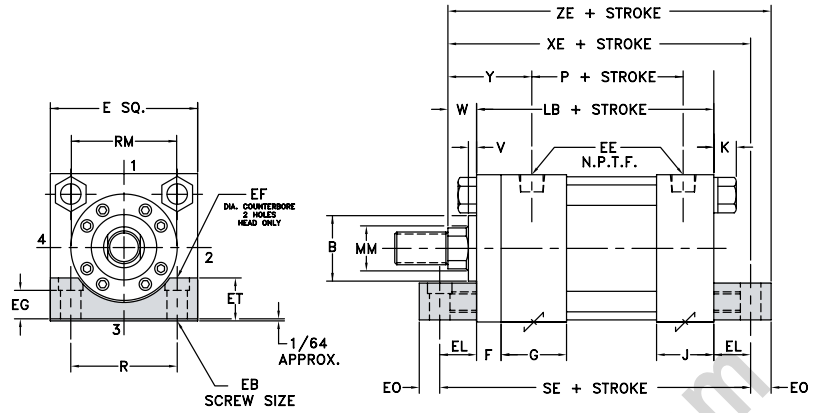

- † HEAD END PORTS SHALLOW TAPPED
- CONSULT FACTORY FOR AVAILABILITY OF SAE PORT OPTION
- Δ (4) SPANNER HOLES USED INSTEAD OF FLATS ON 4" DIA. AND LARGER RODS
- ‡ B DIMENSION TOLERANCE -.001/ -.003
- * SE, XE & ZE DIMENSION CHANGES ON DOUBLE ROD CYLINDERS – SEE PAGE 33 FOR DETAILS.

NOTE: SUGGESTED THAT THESE MOUNTS BE KEYPED OR PINNED TO PREVENT SHIFTING
NOTE: BOTTOMS OF HEAD AND CAP ARE MOUNTING SURFACES. LUGS HOLD CYLINDER AGAINST MOUNTING SURFACE.
NOTE: CHECK FOR CLEARANCE BETWEEN FRONT MOUNTING LUG AND ROD END ATTACHMENT.
 SPECIFY LONGER THAN STANDARD "W" DIMENSION IF NECESSARY.

Air-Oil Systems, Inc. www.airoil.com

STANDARD ROD ENDS

#2 STD MALE
NFPA-SM

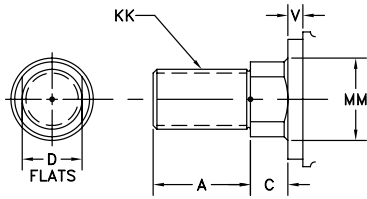

#4 STD FEMALE
NFPA-SF

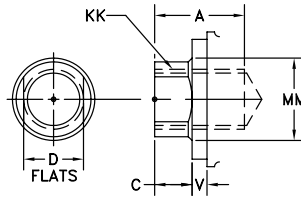

#1 MALE
NFPA-IM

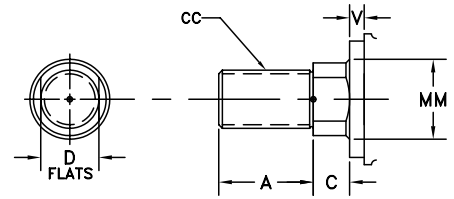

BORE	SAE														ADD STROKE		
	E	EE	OPT.	F	G	J	K	EB	EF	EG	EL	EO	ET	R	LB	P	SE*
1 1/2	2 1/2	1/2	10	3/8	1 3/4	1 1/2	3/8	3/8	5/8	11/16	7/8	3/8	7/8	1.63	5	3	6 3/4
2	3	1/2	10	5/8	1 3/4	1 1/2	7/16	1/2	13/16	3/4	15/16	1/2	15/16	2.05	5 1/4	3	7 1/8
2 1/2	3 1/2	1/2	10	5/8	1 3/4	1 1/2	7/16	1/2	13/16	3/4	15/16	1/2	15/16	2.55	5 3/8	3 1/8	7 1/4
3 1/4	4 1/2	3/4	12	3/4	2	1 3/4	9/16	5/8	1	1 1/16	1 1/8	5/8	1 1/4	3.25	6 1/4	3 5/8	8 1/2
4	5	3/4	12	7/8	2	1 3/4	9/16	5/8	1	15/16	1 1/8	5/8	1 1/4	3.82	6 5/8	3 7/8	8 7/8
5	6 1/2	3/4	12	7/8	2	1 3/4	3/4	7/8	1 3/8	1 1/4	1 1/2	3/4	1 1/2	4.95	7 1/8	4 3/8	10 1/8
6	7 1/2	1	16	1	2 1/4	2 1/4	7/8	1	1 5/8	1 1/2	1 11/16	7/8	1 3/4	5.73	8 3/8	5	11 3/4
7	8 1/2	1 1/4	20	1	2 3/4	2 3/4	1	1 1/8	1 5/8	1 9/16	1 13/16	1	2	6.58	9 1/2	5 1/2	13 1/8
8	9 1/2	1 1/2	24	1	3	3	1 1/16	1 1/4	2 3/32	1 3/4	2	1 1/8	2	7.50	10 1/2	6 1/4	14 1/2

BORE	ROD DIA.	THREAD		ROD EXTENSIONS AND PILOT DIMENSIONS								ADD STROKE	
	MM	KK	CC	A	B†	C	D	V	Y	W	XE*	ZE*	
1 1/2	5/8	7/16-20	1/2-20	3/4	1 1/8	3/8	1/2	1/4	1 15/16	5/8	6 1/2	6 7/8	
	1 †	3/4-16	7/8-14	1 1/8	1 1/2	1/2	7/8	1/2	2 5/16	1	6 7/8	7 1/4	
2	1	3/4-16	7/8-14	1 1/8	1 1/2	1/2	7/8	1/4	2 5/16	3/4	6 15/16	7 7/16	
	1 3/8 †	1-14	1 1/4-12	1 5/8	2	5/8	1 1/8	3/8	2 9/16	1	7 3/16	7 11/16	
2 1/2	1	3/4-16	7/8-14	1 1/8	1 1/2	1/2	7/8	1/4	2 5/16	3/4	7 1/16	7 9/16	
	1 3/8 †	1-14	1 1/4-12	1 5/8	2	5/8	1 1/8	3/8	2 9/16	1	7 5/16	7 13/16	
3 1/4	1 3/8	1-14	1 1/4-12	1 5/8	2	5/8	1 1/8	1/4	2 11/16	7/8	8 1/4	8 7/8	
	1 3/4	1 1/4-12	1 1/2-12	2	2 3/8	3/4	1 1/2	3/8	2 15/16	1 1/8	8 1/2	9 1/8	
4	2 †	1 1/2-12	1 3/4-12	2 1/4	2 5/8	7/8	1 3/4	3/8	3 1/16	1 1/4	8 5/8	9 1/4	
	1 3/4	1 1/4-12	1 1/2-12	2	2 3/8	3/4	1 1/2	1/4	2 15/16	1	8 3/4	9 3/8	
5	2	1 1/2-12	1 3/4-12	2 1/4	2 5/8	7/8	1 3/4	1/4	3 1/16	1 1/8	8 7/8	9 1/2	
	2 1/2	1 7/8-12	2 1/4-12	3	3 1/8	1	2 1/8	3/8	3 5/16	1 3/8	9 1/8	9 3/4	
6	2 1/2	1 1/2-12	1 3/4-12	2 1/4	2 5/8	7/8	1 3/4	1/4	3 1/16	1 1/8	9 3/4	10 1/2	
	2 1/2	1 7/8-12	2 1/4-12	3	3 1/8	1	2 1/8	3/8	3 5/16	1 3/8	10	10 3/4	
7	3	2 1/4-12	2 3/4-12	3 1/2	3 3/4	1	2 5/8	3/8	3 5/16	1 3/8	10	10 3/4	
	3 1/2	2 1/2-12	3 1/4-12	3 1/2	4 1/4	1	3	3/8	3 5/16	1 3/8	10	10 3/4	
8	2 1/2	1 7/8-12	2 1/4-12	3	3 1/8	1	2 1/8	1/4	3 7/16	1 1/4	11 5/16	12 3/16	
	3	2 1/4-12	2 3/4-12	3 1/2	3 3/4	1	2 5/8	1/4	3 7/16	1 1/4	11 5/16	12 3/16	
9	3 1/2	2 1/2-12	3 1/4-12	3 1/2	4 1/4	1	3	1/4	3 7/16	1 1/4	11 5/16	12 3/16	
	4	3-12	3 3/4-12	4	4 3/4	1	Δ	1/4	3 7/16	1 1/4	11 5/16	12 3/16	
10	3	2 1/4-12	2 3/4-12	3 1/2	3 3/4	1	2 5/8	1/4	3 3/4	1 1/4	12 9/16	13 9/16	
	3 1/2	2 1/2-12	3 1/4-12	3 1/2	4 1/4	1	3	1/4	3 3/4	1 1/4	12 9/16	13 9/16	
11	4	3-12	3 3/4-12	4	4 3/4	1	Δ	1/4	3 3/4	1 1/4	12 9/16	13 9/16	
	4 1/2	3 1/4-12	4 1/4-12	4 1/2	5 1/4	1	Δ	1/4	3 3/4	1 1/4	12 9/16	13 9/16	
12	5	3 1/2-12	4 3/4-12	5	5 3/4	1	Δ	1/4	3 3/4	1 1/4	12 9/16	13 9/16	
	3 1/2	2 1/2-12	3 1/4-12	3 1/2	4 1/4	1	3	1/4	3 7/8	1 1/4	13 3/4	14 7/8	
13	4	3-12	3 3/4-12	4	4 3/4	1	Δ	1/4	3 7/8	1 1/4	13 3/4	14 7/8	
	4 1/2	3 1/4-12	4 1/4-12	4 1/2	5 1/4	1	Δ	1/4	3 7/8	1 1/4	13 3/4	14 7/8	
14	5	3 1/2-12	4 3/4-12	5	5 3/4	1	Δ	1/4	3 7/8	1 1/4	13 3/4	14 7/8	
	5 1/2	4-12	5 1/4-12	5 1/2	6 1/4	1	Δ	1/4	3 7/8	1 1/4	13 3/4	14 7/8	



SPHERICAL BEARING MOUNT

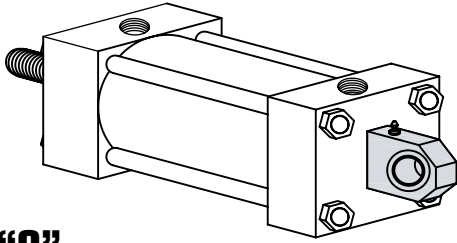

“Q”
YATES STYLE Q
NFPA-MPU3

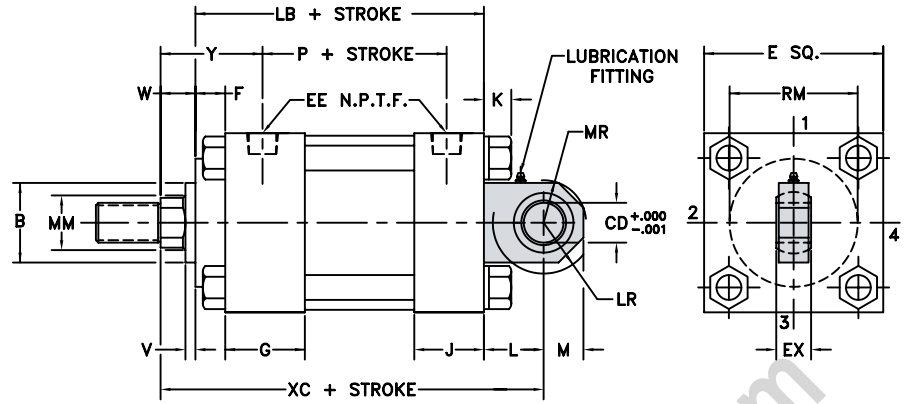

- † HEAD END PORTS SHALLOW TAPPED
- CONSULT FACTORY FOR AVAILABILITY OF SAE PORT OPTION
- Δ (4) SPANNER HOLES USED INSTEAD OF FLATS ON 4" DIA. AND LARGER RODS
- § THESE CYLINDERS HAVE FULL PLATE RETAINERS. USE "E" DIMENSIONS INSTEAD OF "RM" – SEE PAGE 8
- ‡ B DIMENSION TOLERANCE $-.001/-.003$

NOTE: Q MOUNT MAX OPERATING PSI BASED ON STANDARD COMMERCIAL BEARING RATINGS

Air-Oil Systems, Inc. www.airoil.com

STANDARD ROD ENDS

#2 STD MALE
NFPA-SM

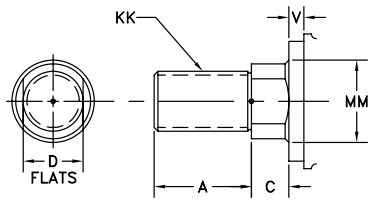

#4 STD FEMALE
NFPA-SF

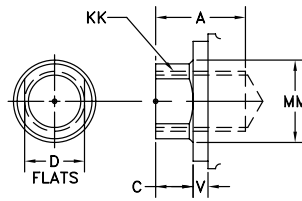

#1 MALE
NFPA-IM

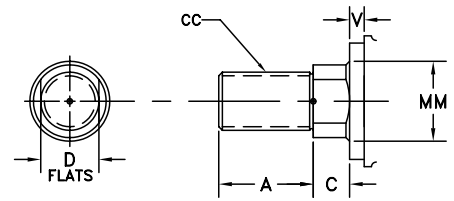

BORE	SAE													ADD STROKE	
	CD	EX	E	EE	OPT.	F	G	J	L	LR	M	MR	K	LB	P
1 1/2	1/2	7/16	2 1/2	1/2	10	3/8	1 3/4	1 1/2	3/4	9/16	3/4	13/16	3/8	5	3
2	3/4	21/32	3	1/2	10	5/8	1 3/4	1 1/2	1 1/4	1 1/16	1	1 1/8	7/16	5 1/4	3
2 1/2	3/4	21/32	3 1/2	1/2	10	5/8	1 3/4	1 1/2	1 1/4	1 1/16	1	1 1/8	7/16	5 3/8	3 1/8
3 1/4	1	7/8	4 1/2	3/4	12	3/4	2	1 3/4	1 1/2	1 1/4	1 1/4	1 3/8	9/16	6 1/4	3 5/8
4	1 3/8	1 3/16	5	3/4	12	7/8	2	1 3/4	2 1/8	1 7/8	1 7/8	2 1/16	9/16	6 5/8	3 7/8
5	1 3/4	1 17/32	6 1/2	3/4	12	7/8	2	1 3/4	2 1/4	1 15/16	2 1/2	2 3/4	3/4	7 1/8	4 3/8
6	2	1 3/4	7 1/2	1	16	1	2 1/4	2 1/4	2 1/2	2 1/16	2 1/2	2 3/4	7/8	8 3/8	5

BORE	ROD DIA.	THREAD		ROD EXTENSIONS AND PILOT DIMENSIONS								ADD STROKE	"Q" MOUNT MAX
	MM	KK	CC	A	B ‡	C	D	V	W	Y	RM	XC	OPER. PSI
1 1/2	5/8	7/16-20	1/2-20	3/4	1 1/8	3/8	1/2	1/4	5/8	1 15/16	§	6 3/8	1675
	1 †	3/4-16	7/8-14	1 1/8	1 1/2	1/2	7/8	1/2	1	2 5/16	§	6 3/4	
2	1	3/4-16	7/8-14	1 1/8	1 1/2	1/2	7/8	1/4	3/4	2 5/16	§	7 1/4	2185
	1 3/8 †	1-14	1 1/4-12	1 5/8	2	5/8	1 1/8	3/8	1	2 9/16	§	7 1/2	
2 1/2	1	3/4-16	7/8-14	1 1/8	1 1/2	1/2	7/8	1/4	3/4	2 5/16	2 5/8	7 3/8	1410
	1 3/8 †	1-14	1 1/4-12	1 5/8	2	5/8	1 1/8	3/8	1	2 9/16	§	7 5/8	
3 1/4	1 3/4 †	1 1/4-12	1 1/2-12	2	2 3/8	3/4	1 1/2	1/2	1 1/4	2 13/16	§	7 7/8	1490
	1 3/8	1-14	1 1/4-12	1 5/8	2	5/8	1 1/8	1/4	7/8	2 11/16	3 7/32	8 5/8	
4	1 3/4	1 1/4-12	1 1/2-12	2	2 3/8	3/4	1 1/2	3/8	1 1/8	2 15/16	§	8 7/8	1800
	2 †	1 1/2-12	1 3/4-12	2 1/4	2 5/8	7/8	1 3/4	3/8	1 1/4	3 1/16	§	9	
5	1 3/4	1 1/4-12	1 1/2-12	2	2 3/8	3/4	1 1/2	1/4	1	2 15/16	3 7/8	9 3/4	1925
	2	1 1/2-12	1 3/4-12	2 1/4	2 5/8	7/8	1 3/4	1/4	1 1/8	3 1/16	4	9 7/8	
6	2 1/2	1 7/8-12	2 1/4-12	3	3 1/8	1	2 1/8	3/8	1 3/8	3 5/16	4 7/16	10 1/8	1765
	2	1 1/2-12	1 3/4-12	2 1/4	2 5/8	7/8	1 3/4	1/4	1 1/8	3 1/16	4	10 1/2	
6	2 1/2	1 7/8-12	2 1/4-12	2 1/4	2 5/8	7/8	1 3/4	1/4	1 1/8	3 1/16	4	10 1/2	1765
	2 1/2	1 7/8-12	2 1/4-12	3	3 1/8	1	2 1/8	3/8	1 3/8	3 5/16	4 7/16	10 3/4	
6	3	2 1/4-12	2 3/4-12	3 1/2	3 3/4	1	2 5/8	3/8	1 3/8	3 5/16	5 1/4	10 3/4	1765
	3 1/2	2 1/2-12	3 1/4-12	3 1/2	4 1/4	1	3	3/8	1 3/8	3 5/16	5 5/8	10 3/4	
6	2 1/2	1 7/8-12	2 1/4-12	3	3 1/8	1	2 1/8	1/4	1 1/4	3 7/16	4 7/16	12 1/8	1765
	3	2 1/4-12	2 3/4-12	3 1/2	3 3/4	1	2 5/8	1/4	1 1/4	3 7/16	5 1/4	12 1/8	
6	3 1/2	2 1/2-12	3 1/4-12	3 1/2	4 1/4	1	3	1/4	1 1/4	3 7/16	5 5/8	12 1/8	1765
	4	3-12	3 3/4-12	4	4 3/4	1	Δ	1/4	1 1/4	3 7/16	6 7/16	12 1/8	



CAP FIXED CLEVIS MOUNT

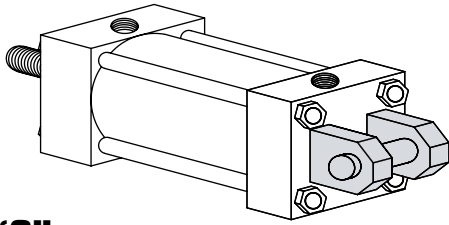

“C”
YATES STYLE C
NFPA-MP1

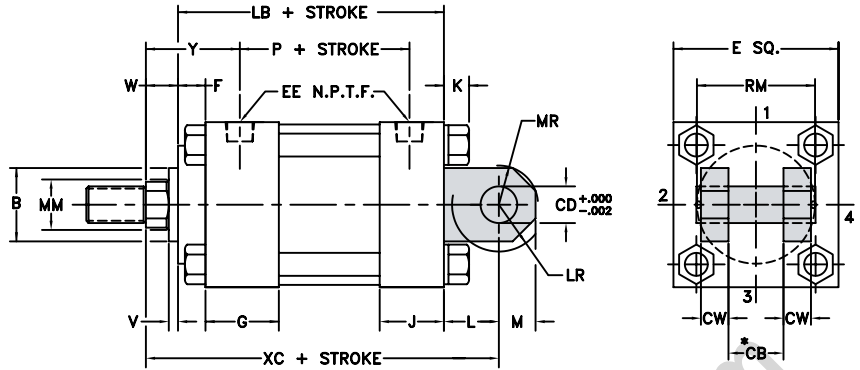

CAP FIXED EYE MOUNT

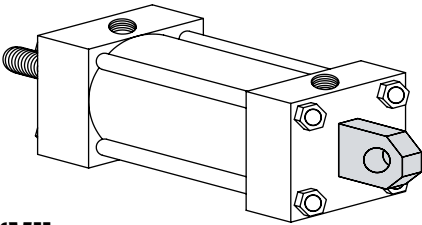

“V”
YATES STYLE V
NFPA-MP3

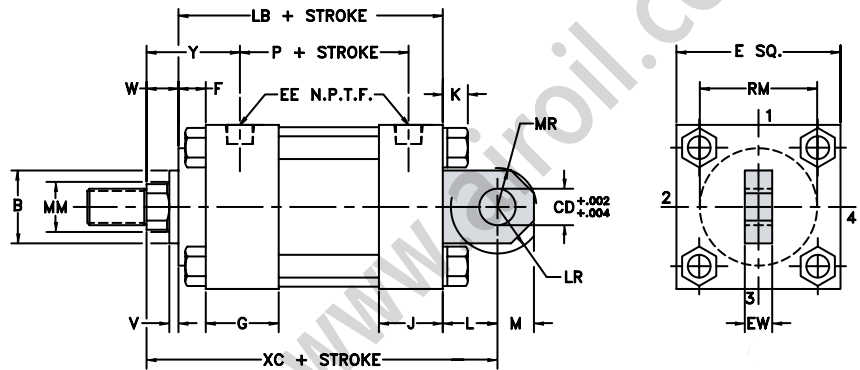

- † HEAD END PORTS SHALLOW TAPPED
- CONSULT FACTORY FOR AVAILABILITY OF SAE PORT OPTION
- Δ (4) SPANNER HOLES USED INSTEAD OF FLATS ON 4" DIA. AND LARGER RODS
- § THESE CYLINDERS HAVE FULL PLATE RETAINERS. USE "E" DIMENSION INSTEAD OF "RM" -- SEE PAGE 8
- ‡ B DIMENSION TOLERANCE $-.001 / -.003$
- * MAX WIDTH OF MATING PART

"EW" DESIGNED TO FIT YATES STD CLEVIS BRACKET

STANDARD ROD ENDS

#2 STD MALE
NFPA-SM

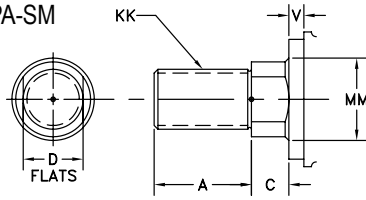

#4 STD FEMALE
NFPA-SF

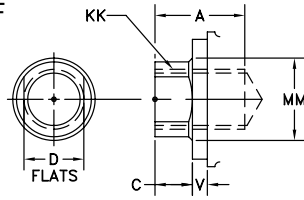

#1 MALE
NFPA-IM

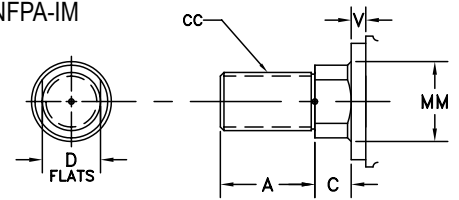

BORE	CB*	CD	CW	EW*	E	EE	SAE OPT.	F	G	J	L	LR	M	MR	K	ADD STROKE	
																LB	P
1 1/2	3/4	1/2	1/2	3/4	2 1/2	1/2	10	3/8	1 3/4	1 1/2	3/4	9/16	1/2	9/16	3/8	5	3
2	1 1/4	3/4	5/8	1 1/4	3	1/2	10	5/8	1 3/4	1 1/2	1 1/4	1 1/16	3/4	7/8	7/16	5 1/4	3
2 1/2	1 1/4	3/4	5/8	1 1/4	3 1/2	1/2	10	5/8	1 3/4	1 1/2	1 1/4	1 1/16	3/4	7/8	7/16	5 3/8	3 1/8
3 1/4	1 1/2	1	3/4	1 1/2	4 1/2	3/4	12	3/4	2	1 3/4	1 1/2	1 1/4	1	1 1/8	9/16	6 1/4	3 5/8
4	2	1 3/8	1	2	5	3/4	12	7/8	2	1 3/4	2 1/8	1 7/8	1 3/8	1 1/2	9/16	6 5/8	3 7/8
5	2 1/2	1 3/4	1 1/4	2 1/2	6 1/2	3/4	12	7/8	2	1 3/4	2 1/4	1 15/16	1 3/4	1 7/8	3/4	7 1/8	4 3/8
6	2 1/2	2	1 1/4	2 1/2	7 1/2	1	16	1	2 1/4	2 1/4	2 1/2	2 1/16	2	2 3/16	7/8	8 3/8	5
7	3	2 1/2	1 1/2	3	8 1/2	1 1/4	20	1	2 3/4	2 3/4	3	2 9/16	2 1/2	2 3/4	1	9 1/2	5 1/2
8	3	3	1 1/2	3	9 1/2	1 1/2	24	1	3	3	3 1/4	2 11/16	2 3/4	3	1 11/16	10 1/2	6 1/4
10	4	3 1/2	2	4	12 5/8	2	32	7/8	3 11/16	3 11/16	4	3 3/8	3 1/2	3 13/16	1	13	8 1/8

BORE	ROD DIA. MM	THREAD		ROD EXTENSIONS AND PILOT DIMENSIONS								ADD STROKE XC
		MM	KK	CC	A	B±	C	D	V	W	Y	
1 1/2	5/8	7/16-20	1/2-20	3/4	1 1/8	3/8	1/2	1/4	5/8	1 15/16	§	6 3/8
	1†	3/4-16	7/8-14	1 1/8	1 1/2	1/2	7/8	1/2	1	2 5/16	§	6 3/4
2	1	3/4-16	7/8-14	1 1/8	1 1/2	1/2	7/8	1/4	3/4	2 5/16	§	7 1/4
	1 3/8†	1-14	1 1/4-12	1 5/8	2	5/8	1 1/8	3/8	1	2 9/16	§	7 1/2
2 1/2	1	3/4-16	7/8-14	1 1/8	1 1/2	1/2	7/8	1/4	3/4	2 5/16	2 5/8	7 3/8
	1 3/8†	1-14	1 1/4-12	1 5/8	2	5/8	1 1/8	3/8	1	2 9/16	§	7 5/8
3 1/4	1 3/4†	1 1/4-12	1 1/2-12	2	2 3/8	3/4	1 1/2	1/2	1 1/4	2 13/16	§	7 7/8
	1 3/8	1-14	1 1/4-12	1 5/8	2	5/8	1 1/8	1/4	7/8	2 11/16	3 7/32	8 5/8
4	1 3/4	1 1/4-12	1 1/2-12	2	2 3/8	3/4	1 1/2	3/8	1 1/8	2 15/16	§	8 7/8
	2	1 1/2-12	1 3/4-12	2 1/4	2 5/8	7/8	1 3/4	3/8	1 1/4	3 1/16	§	9
5	1 3/4	1 1/4-12	1 1/2-12	2	2 3/8	3/4	1 1/2	1/4	1	2 15/16	3 7/8	9 3/4
	2	1 1/2-12	1 3/4-12	2 1/4	2 5/8	7/8	1 3/4	1/4	1 1/8	3 1/16	4	9 7/8
6	2 1/2	1 7/8-12	2 1/4-12	3	3 1/8	1	2 1/8	3/8	1 3/8	3 5/16	4 7/16	10 1/8
	2	1 1/2-12	1 3/4-12	2 1/4	2 5/8	7/8	1 3/4	1/4	1 1/8	3 1/16	4	10 1/2
7	2 1/2	1 7/8-12	2 1/4-12	3	3 1/8	1	2 1/8	3/8	1 3/8	3 5/16	4 7/16	10 3/4
	3	2 1/4-12	2 3/4-12	3 1/2	3 3/4	1	2 5/8	3/8	1 3/8	3 5/16	5 1/4	10 3/4
8	3 1/2	2 1/2-12	3 1/4-12	3 1/2	4 1/4	1	3	3/8	1 3/8	3 5/16	5 5/8	10 3/4
	2 1/2	1 7/8-12	2 1/4-12	3	3 1/8	1	2 1/8	1/4	1 1/4	3 7/16	4 7/16	12 1/8
9	3	2 1/4-12	2 3/4-12	3 1/2	3 3/4	1	2 5/8	1/4	1 1/4	3 7/16	5 1/4	12 1/8
	3 1/2	2 1/2-12	3 1/4-12	3 1/2	4 1/4	1	3	1/4	1 1/4	3 7/16	5 5/8	12 1/8
10	4	3-12	3 3/4-12	4	4 3/4	1	Δ	1/4	1 1/4	3 7/16	6 7/16	12 1/8
	3	2 1/4-12	2 3/4-12	3 1/2	3 3/4	1	2 5/8	1/4	1 1/4	3 3/4	5 1/4	13 3/4
11	3 1/2	2 1/2-12	3 1/4-12	3 1/2	4 1/4	1	3	1/4	1 1/4	3 3/4	5 5/8	13 3/4
	4	3-12	3 3/4-12	4	4 3/4	1	Δ	1/4	1 1/4	3 3/4	6 7/16	13 3/4
12	4 1/2	3 1/4-12	4 1/4-12	4 1/2	5 1/4	1	Δ	1/4	1 1/4	3 3/4	7 1/8	13 3/4
	5	3 1/2-12	4 3/4-12	5	5 3/4	1	Δ	1/4	1 1/4	3 3/4	7 5/8	13 3/4
13	3 1/2	2 1/2-12	3 1/4-12	3 1/2	4 1/4	1	3	1/4	1 1/4	3 7/8	5 5/8	15
	4	3-12	3 3/4-12	4	4 3/4	1	Δ	1/4	1 1/4	3 7/8	6 7/16	15
14	4 1/2	3 1/4-12	4 1/4-12	4 1/2	5 1/4	1	Δ	1/4	1 1/4	3 7/8	7 1/8	15
	5	3 1/2-12	4 3/4-12	5	5 3/4	1	Δ	1/4	1 1/4	3 7/8	7 5/8	15
15	5 1/2	4-12	5 1/4-12	5 1/2	6 1/4	1	Δ	1/4	1 1/4	3 7/8	8 3/8	15
	4 1/2	3 1/4-12	4 1/4-12	4 1/2	5 1/4	1	Δ	1 1/16	2 1/16	4 15/16	7 1/8	19 1/16
16	5	3 1/2-12	4 3/4-12	5	5 3/4	1	Δ	1 5/16	2 5/16	5 3/16	7 5/8	19 5/16
	5 1/2	4-12	5 1/4-12	5 1/2	6 1/4	1	Δ	1 5/16	2 5/16	5 3/16	8 3/8	19 5/16
17	7	5-12	6 1/2-12	7	8	1	Δ	1 5/8	2 5/8	5 1/2	10 7/8	19 5/8



CAP FIXED CLEVIS MOUNT

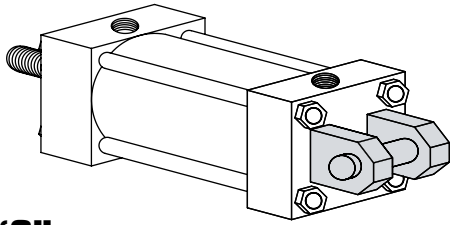

“C”
YATES STYLE C
NFPA-MP1

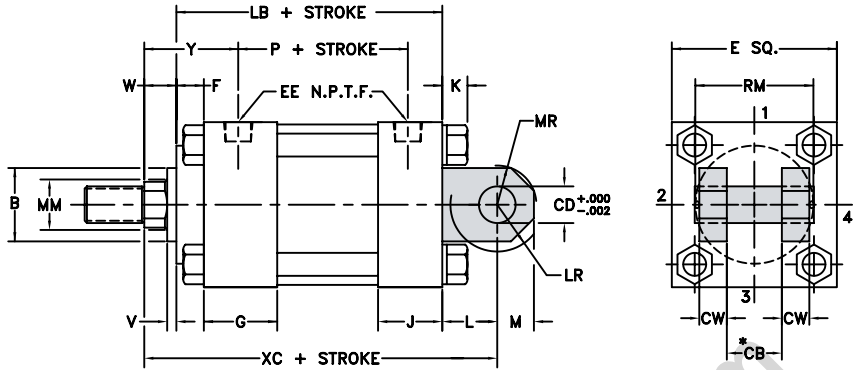

CAP FIXED EYE MOUNT

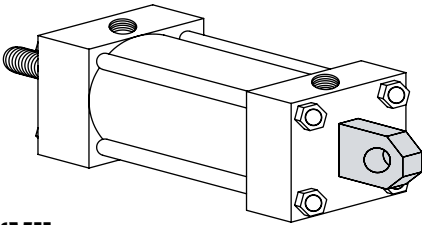

“V”
YATES STYLE V
NFPA-MP3

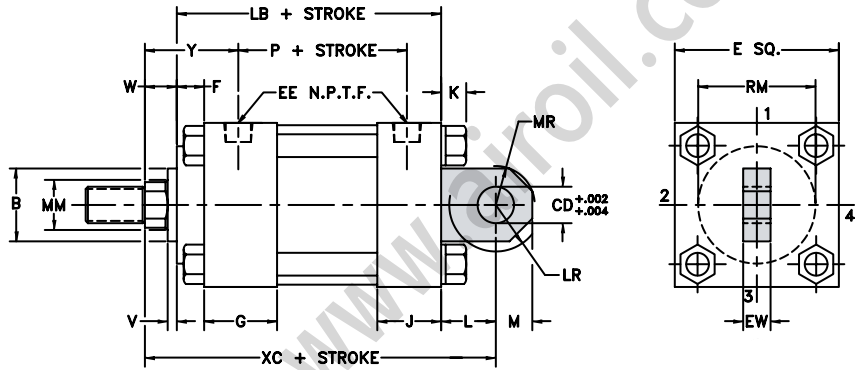

Air-Oil Systems, Inc.

STANDARD ROD ENDS

#2 STD MALE NFPA-SM

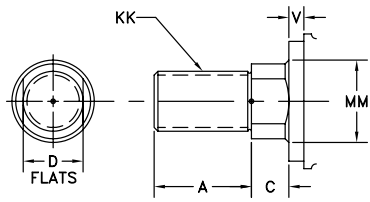

#4 STD FEMALE NFPA-SF

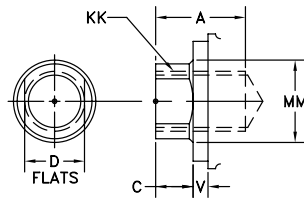

#1 MALE NFPA-IM

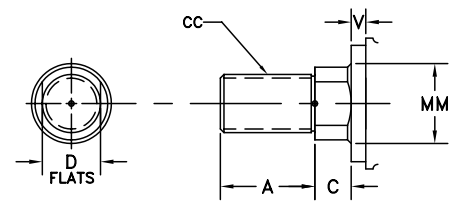

BORE	CB*	CD	CW	EW*	E	EE	SAE OPT.	F	G	J	L	LR	M	MR	K	ADD STROKE	
																LB	P
12	4 1/2	4	2 1/4	4 1/2	14 7/8	2 1/2	32	1 3/8	4 7/16	4 7/16	4 1/2	3 7/8	4	4 3/8	1 1/16	15 7/8	9 1/2
14	6	5	3	6	17 1/8	2 1/2	32	1 5/8	4 7/8	4 7/8	5 3/4	4 3/16	5	5 7/16	1 1/16	17 1/4	9 7/8
16	7	6	3 1/2	7	19 1/4	3	32	1 7/8	5 7/8	5 7/8	7	4 3/4	6	6 1/2	1 9/32	20	11
18	8	6 1/2	4	8	22	3	32	2 3/16	6 7/8	6 7/8	7 5/8	5 1/16	6 1/2	7 1/16	1 9/32	23 15/16	12
20	9	7 1/2	4 1/2	9	23 5/8	3	32	2 11/16	7 7/8	7 7/8	8 3/4	6 3/16	7 1/2	8 1/8	1 9/32	26 5/16	12 1/2

BORE	ROD DIA.	THREAD		ROD EXTENSIONS AND PILOT DIMENSIONS									ADD STROKE
	MM	KK	CC	A	B±	C	D	V	W	Y	RM	XC	
12	5 1/2	4-12	4 1/4-12	5 1/2	6 1/4	1	Δ	13/16	1 13/16	5 11/16	8 3/8	22 3/16	
	7	5-12	6 1/2-12	7	8	1	Δ	1 1/8	2 1/8	6	10 7/8	22 1/2	
	8	5 3/4-12	7 1/2-12	8	9	1	Δ	1 5/8	2 5/8	6 1/2	12 3/8	23	
14	7	5-12	6 1/2-12	7	8	1	Δ	7/8	1 7/8	6 3/8	10 13/16	24 7/8	
	8	5 3/4-12	7 1/2-12	8	9	1	Δ	1 3/8	2 3/8	6 7/8	12 3/8	25 3/8	
	9	6 1/2-12	8 1/2-12	9	10	1	Δ	1 5/8	2 5/8	7 1/8	13 1/8	25 5/8	
16	10	7 1/4-12	9 1/2-12	10	11	1	Δ	1 7/8	2 7/8	7 3/8	14 5/8	25 7/8	
	8	5 3/4-12	7 1/2-12	8	9	1	Δ	1 1/8	2 1/8	7 9/16	14 5/8	29 1/8	
	9	6 1/2-12	8 1/2-12	9	10	1	Δ	1 3/8	2 3/8	7 13/16	13 1/8	29 3/8	
18	10	7 1/4-12	9 1/2-12	10	11	1	Δ	1 5/8	2 5/8	8 1/16	14 5/8	29 5/8	
	9	6 1/2-12	8 1/2-12	9	10	1	Δ	1 1/16	2 1/16	8 13/16	13 1/8	33	
	10	7 1/4-12	9 1/2-12	10	11	1	Δ	1 5/16	2 5/16	9 1/16	14 5/8	33 1/4	
20	10	7 1/4-12	9 1/2-12	10	11	1	Δ	13/16	1 13/16	10 1/16	14 5/8	36 7/8	

Δ (4) SPANNER HOLES USED INSTEAD OF FLATS ON 4" DIA. AND LARGER RODS
 ‡ B DIMENSION TOLERANCE -.001/-.003
 * MAX WIDTH OF MATING PART



INTERMEDIATE FIXED TRUNNION MOUNT

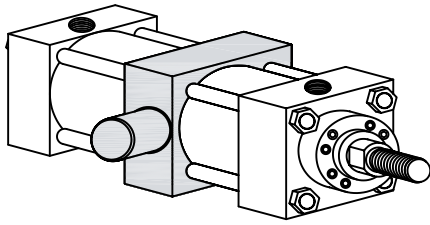

“T”
YATES STYLE **T**
NFPA-MT4

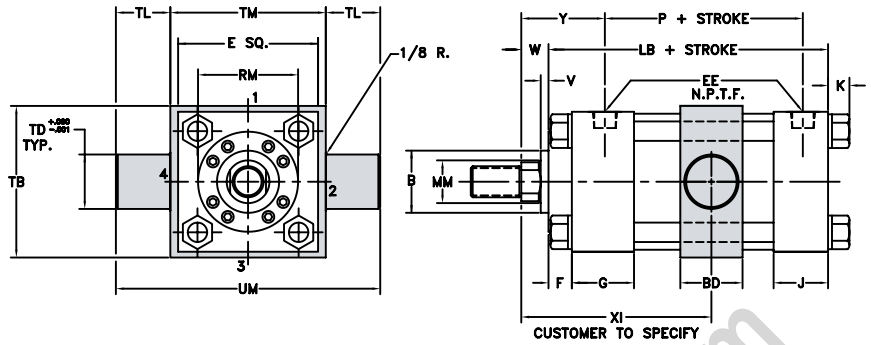

HEAD TRUNNION MOUNT

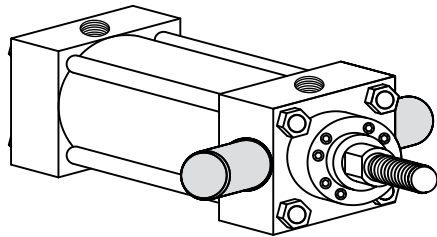

“U”
YATES STYLE **U**
NFPA-MT1

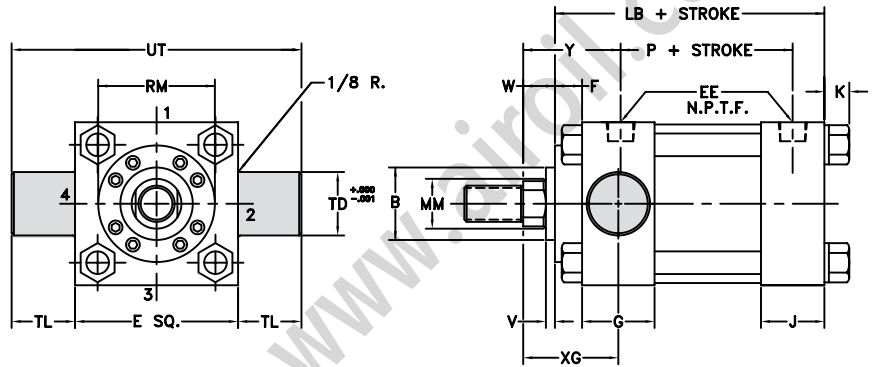

CAP TRUNNION MOUNT

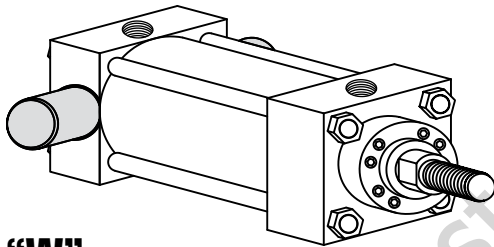

“W”
YATES STYLE **W**
NFPA-MT2

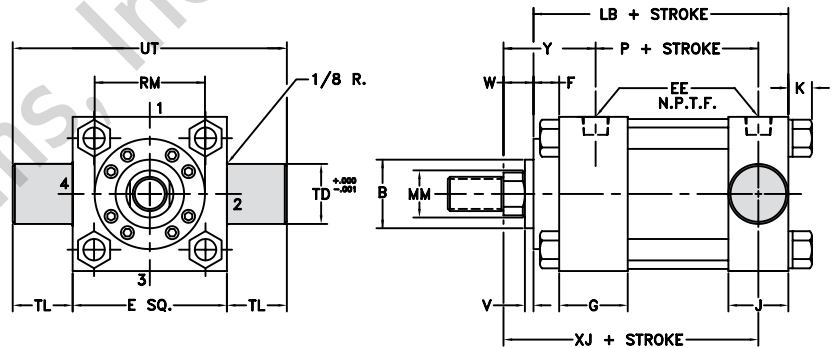

STANDARD ROD ENDS

#2 STD MALE
NFPA-SM

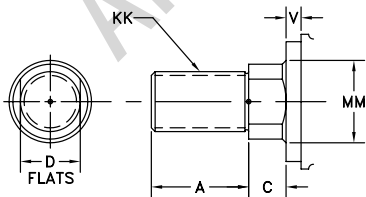

#4 STD FEMALE
NFPA-SF

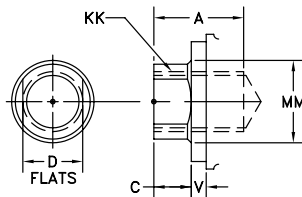

#1 MALE
NFPA-IM

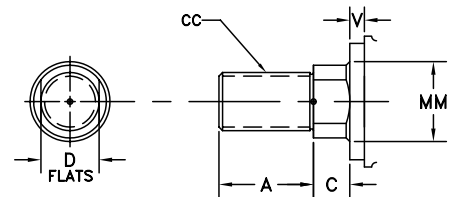

BORE	SAE															ADD STROKE	
	E	EE	OPT.	F	G	J	K	TD	TL	TB	TM	UM	UT	BD	XI	LB	P
1 1/2	2 1/2	1/2	10	3/8	1 3/4	1 1/2	3/8	1	1	2 3/4	3	5	4 1/2	1 1/4	CUSTOMER TO SPECIFY	5	3
2	3	1/2	10	5/8	1 3/4	1 1/2	7/16	1 3/8	1 3/8	3 3/8	3 1/2	6 1/4	5 3/4	1 3/4		5 1/4	3
2 1/2	3 1/2	1/2	10	5/8	1 3/4	1 1/2	7/16	1 3/8	1 3/8	3 7/8	4	6 3/4	6 1/4	2		5 3/8	3 1/8
3 1/4	4 1/2	3/4	12	3/4	2	1 3/4	9/16	1 3/4	1 3/4	4 7/8	5	8 1/2	8	2 1/4		6 1/4	3 5/8
4	5	3/4	12	7/8	2	1 3/4	9/16	1 3/4	1 3/4	5 1/2	5 1/2	9	8 1/2	2 1/4		6 5/8	3 7/8
5	6 1/2	3/4	12	7/8	2	1 3/4	3/4	1 3/4	1 3/4	7 1/4	7	10 1/2	10	3		7 1/8	4 3/8
6	7 1/2	1	16	1	2 1/4	2 1/4	7/8	2	2	8 1/2	8 1/2	12 1/2	11 1/2	3 1/2		8 3/8	5
7	8 1/2	1 1/4	20	1	2 3/4	2 3/4	1	2 1/2	2 1/2	9 3/4	9 3/4	14 3/4	13 1/2	4		9 1/2	5 1/2
8	9 1/2	1 1/2	24	1	3	3	1 1/16	3	3	11	11	17	15 1/2	4 1/4		10 1/2	6 1/4
10	12 5/8	2	32	7/8	3 11/16	3 11/16	1	3 1/2	3 1/2	N/A	N/A	N/A	19 5/8	N/A		N/A	13

BORE	ROD DIA.	THREAD		ROD EXTENSIONS AND PILOT DIMENSIONS										ADD STROKE
		MM	KK	CC	A	B ‡	C	D	V	W	Y	RM	XG	
1 1/2	5/8	7/16-20	1/2-20	3/4	1 1/8	3/8	1/2	1/4	5/8	1 15/16	§	1 7/8	4 7/8	
	1 †	3/4-16	7/8-14	1 1/8	1 1/2	1/2	7/8	1/2	1	2 5/16	§	2 1/4	5 1/4	
2	1	3/4-16	7/8-14	1 1/8	1 1/2	1/2	7/8	1/4	3/4	2 5/16	§	2 1/4	5 1/4	
	1 3/8 †	1-14	1 1/4-12	1 5/8	2	5/8	1 1/8	3/8	1	2 9/16	§	2 1/2	5 1/2	
2 1/2	1	3/4-16	7/8-14	1 1/8	1 1/2	1/2	7/8	1/4	3/4	2 5/16	2 5/8	2 1/4	5 3/8	
	1 3/8 †	1-14	1 1/4-12	1 5/8	2	5/8	1 1/8	3/8	1	2 9/16	§	2 1/2	5 5/8	
3 1/4	1 3/4 †	1 1/4-12	1 1/2-12	2	2 3/8	3/4	1 1/2	1/2	1 1/4	2 13/16	§	2 3/4	5 7/8	
	1 3/4	1 1/4-12	1 1/2-12	2	2 3/8	3/4	1 1/2	3/8	1 1/8	2 15/16	§	2 7/8	6 1/2	
	2 †	1 1/2-12	1 3/4-12	2 1/4	2 5/8	7/8	1 3/4	3/8	1 1/4	3 1/16	§	3	6 5/8	
4	1 3/4	1 1/4-12	1 1/2-12	2	2 3/8	3/4	1 1/2	1/4	1	2 15/16	3 7/8	2 7/8	6 3/4	
	2	1 1/2-12	1 3/4-12	2 1/4	2 5/8	7/8	1 3/4	1/4	1 1/8	3 1/16	4	3	6 7/8	
5	2 1/2	1 7/8-12	2 1/4-12	3	3 1/8	1	2 1/8	3/8	1 3/8	3 5/16	4 7/16	3 1/4	7 1/8	
	2	1 1/2-12	1 3/4-12	2 1/4	2 5/8	7/8	1 3/4	1/4	1 1/8	3 1/16	4	3	7 3/8	
	2 1/2	1 7/8-12	2 1/4-12	3	3 1/8	1	2 1/8	3/8	1 3/8	3 5/16	4 7/16	3 1/4	7 5/8	
6	3	2 1/4-12	2 3/4-12	3 1/2	3 3/4	1	2 5/8	3/8	1 3/8	3 5/16	5 1/4	3 1/4	7 5/8	
	3 1/2	2 1/2-12	3 1/4-12	3 1/2	4 1/4	1	3	3/8	1 3/8	3 5/16	5 5/8	3 1/4	7 5/8	
	2 1/2	1 7/8-12	2 1/4-12	3	3 1/8	1	2 1/8	1/4	1 1/4	3 7/16	4 7/16	3 3/8	8 3/8	
7	3	2 1/4-12	2 3/4-12	3 1/2	3 3/4	1	2 5/8	1/4	1 1/4	3 3/4	5 1/4	3 5/8	9 3/8	
	3 1/2	2 1/2-12	3 1/4-12	3 1/2	4 1/4	1	3	1/4	1 1/4	3 3/4	5 5/8	3 5/8	9 3/8	
	4	3-12	3 3/4-12	4	4 3/4	1	Δ	1/4	1 1/4	3 3/4	6 7/16	3 5/8	9 3/8	
8	4 1/2	3 1/4-12	4 1/4-12	4 1/2	5 1/4	1	Δ	1/4	1 1/4	3 3/4	7 1/8	3 5/8	9 3/8	
	5	3 1/2-12	4 3/4-12	5	5 3/4	1	Δ	1/4	1 1/4	3 3/4	7 5/8	3 5/8	9 3/8	
	3 1/2	2 1/2-12	3 1/4-12	3 1/2	4 1/4	1	3	1/4	1 1/4	3 7/8	5 5/8	3 3/4	10 1/4	
10	4	3-12	3 3/4-12	4	4 3/4	1	Δ	1/4	1 1/4	3 7/8	6 7/16	3 3/4	10 1/4	
	4 1/2	3 1/4-12	4 1/4-12	4 1/2	5 1/4	1	Δ	1/4	1 1/4	3 7/8	7 1/8	3 3/4	10 1/4	
	5	3 1/2-12	4 3/4-12	5	5 3/4	1	Δ	1/4	1 1/4	3 7/8	7 5/8	3 3/4	10 1/4	
10	5 1/2	4-12	5 1/4-12	5 1/2	6 1/4	1	Δ	1/4	1 1/4	3 7/8	8 3/8	3 3/4	10 1/4	
	4 1/2	3 1/4-12	4 1/4-12	4 1/2	5 1/4	1	Δ	1 1/16	2 1/16	4 15/16	7 1/8	4 3/4	13 1/4	
	5	3 1/2-12	4 3/4-12	5	5 3/4	1	Δ	1 5/16	2 5/16	5 3/16	7 5/8	5	13 1/2	
10	5 1/2	4-12	5 1/4-12	5 1/2	6 1/4	1	Δ	1 5/16	2 5/16	5 3/16	8 3/8	5	13 1/2	
	7	5-12	6 1/2-12	7	8	1	Δ	1 5/8	2 5/8	5 1/2	10 7/8	5 5/16	13 13/16	

† HEAD END PORTS SHALLOW TAPPED
 * CONSULT FACTORY FOR AVAILABILITY OF SAE PORT OPTION
 Δ (4) SPANNER HOLES USED INSTEAD OF FLATS ON 4" DIA. AND LARGER RODS
 § THESE CYLINDERS HAVE FULL PLATE RETAINERS. USE "E" DIMENSION INSTEAD OF "RM" - SEE PAGE 8
 ‡ B DIMENSION TOLERANCE -.001/-.003



HEAD TRUNNION MOUNT

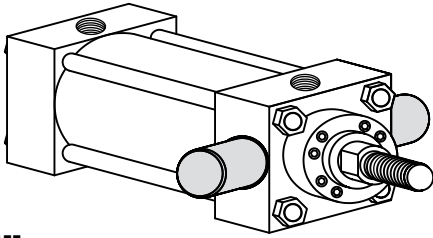

“U”

YATES STYLE **U**
NFPA-MT1

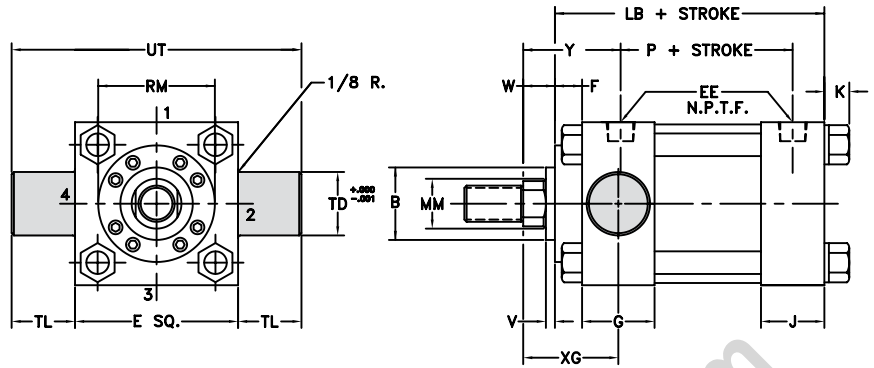

CAP TRUNNION MOUNT

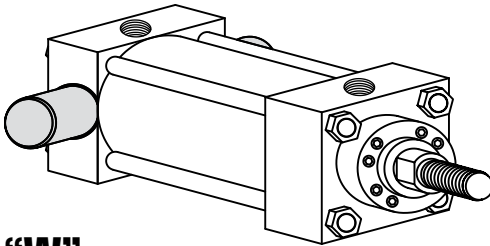

“W”

YATES STYLE **W**
NFPA-MT2

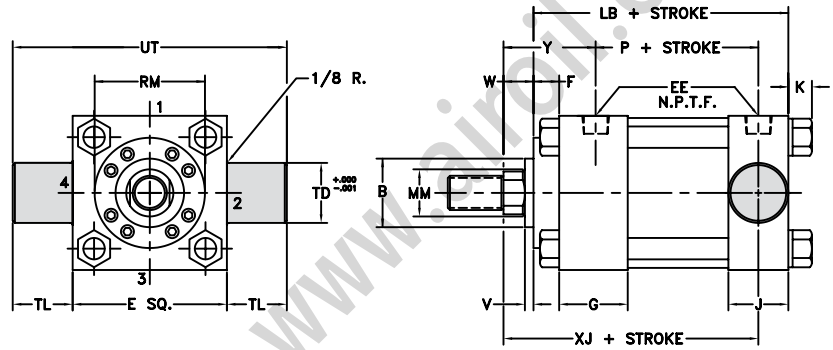

STANDARD ROD ENDS

#2 STD MALE NFPA-SM

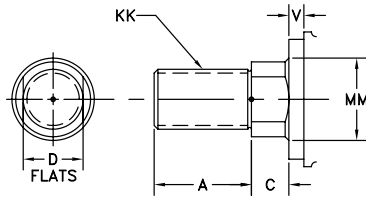

#4 STD FEMALE NFPA-SF

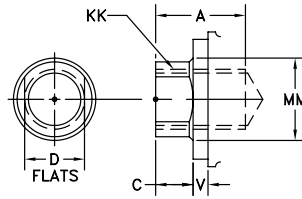

#1 MALE NFPA-IM

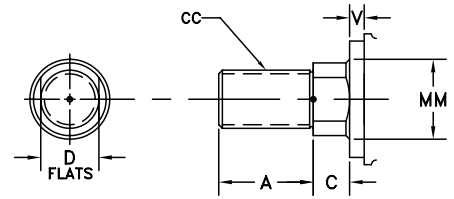

BORE	E	EE	SAE OPT.	F	G	J	K	TD	TL	UT	ADD STROKE	
											LB	P
12	14 7/8	2 1/2	32	1 3/8	4 7/16	4 7/16	1 1/16	4	4	22 7/8	15 7/8	9 1/2
14	17 1/8	2 1/2	32	1 5/8	4 7/8	4 7/8	1 1/16	4 1/2	4 1/2	26 1/8	17 1/4	9 7/8
16	19 1/4	3	32	1 7/8	5 7/8	5 7/8	1 9/32	5	5	29 1/4	20	11
18	22	3	32	2 3/16	6 7/8	6 7/8	1 9/32	5 3/4	5 3/4	33 1/2	23 5/16	12
20	23 5/8	3	32	2 11/16	7 7/8	7 7/8	1 9/32	6 1/4	6 1/4	36 1/8	26 5/16	12 1/2

BORE	ROD DIA.		THREAD		ROD EXTENSIONS AND PILOT DIMENSIONS								ADD STROKE	
	MM	KK	CC	SAE	A	B†	C	D	V	W	Y	RM	XG	XJ
12	5 1/2	4-12	5 1/4-12		5 1/2	6 1/4	1	Δ	13/16	1 13/16	5 11/16	8 3/8	5 3/8	15 1/2
	7	5-12	6 1/2-12		7	8	1	Δ	1 1/8	2 1/8	6	10 7/8	5 11/16	15 13/16
	8	5 3/4-12	7 1/2-12		8	9	1	Δ	1 5/8	2 5/8	6 1/2	12 3/8	6 3/16	16 5/16
14	7	5-12	6 1/2-12		7	8	1	Δ	7/8	1 7/8	6 3/8	10 13/16	5 15/16	16 11/16
	8	5 3/4-12	7 1/2-12		8	9	1	Δ	1 3/8	2 3/8	6 7/8	12 3/8	6 7/16	17 3/16
	9	6 1/2-12	8 1/2-12		9	10	1	Δ	1 5/8	2 5/8	7 1/8	13 1/8	6 11/16	17 7/16
16	10	7 1/4-12	9 1/2-12		10	11	1	Δ	1 7/8	2 7/8	7 3/8	14 5/8	6 15/16	17 11/16
	8	5 3/4-12	7 1/2-12		8	9	1	Δ	1 1/8	2 1/8	7 9/16	12 3/8	6 15/16	19 3/16
	9	6 1/2-12	8 1/2-12		9	10	1	Δ	1 3/8	2 3/8	7 13/16	13 1/8	7 3/16	19 7/16
18	10	7 1/4-12	9 1/2-12		10	11	1	Δ	1 5/8	2 5/8	8 1/16	14 5/8	7 7/16	19 11/16
	9	6 1/2-12	8 1/2-12		9	10	1	Δ	1 1/16	2 1/16	8 13/16	13 1/8	7 15/16	21 15/16
	10	7 1/4-12	9 1/2-12		10	11	1	Δ	1 5/16	2 5/16	9 1/16	14 5/8	7 11/16	22 3/16
20	10	7 1/4-12	9 1/2-12		10	11	1	Δ	1 13/16	1 13/16	10 1/16	14 5/8	8 7/16	24 3/16

† HEAD END PORTS SHALLOW TAPPED
 • CONSULT FACTORY FOR AVAILABILITY OF SAE PORT OPTION
 Δ (4) SPANNER HOLES USED INSTEAD OF FLATS ON 4" DIA. AND LARGER RODS
 § THESE CYLINDERS HAVE FULL PLATE RETAINERS. USE "E" DIMENSION INSTEAD OF "RM" - SEE PAGE 8
 ‡ B DIMENSION TOLERANCE -.001/-.003



HEAD RECTANGULAR FLANGE MOUNT

"F"

YATES STYLE **F**
NFPA-MF1

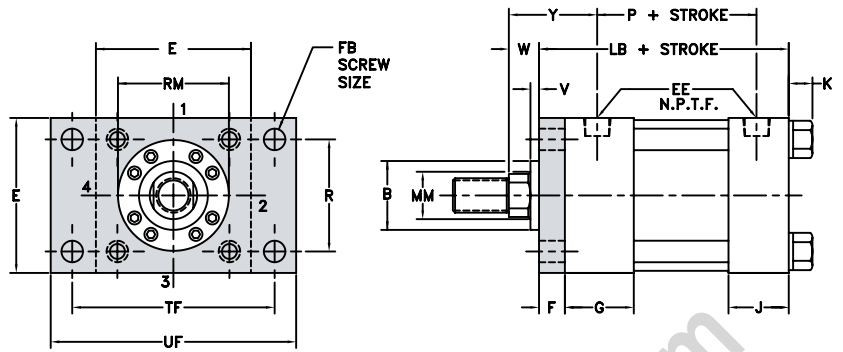
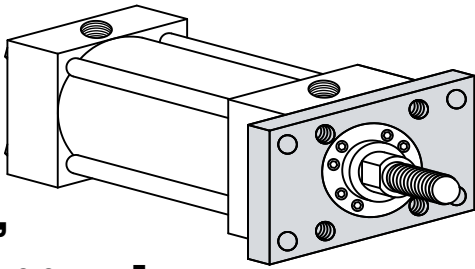

HEAD SQUARE FLANGE MOUNT

"J"

YATES STYLE **J**
NFPA-MF5

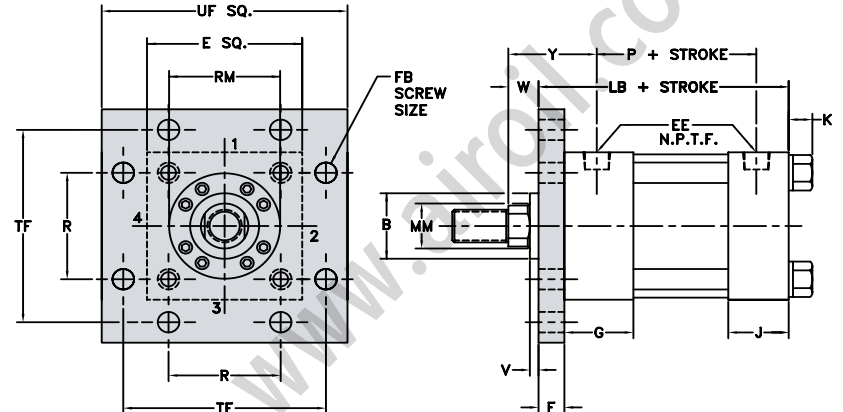
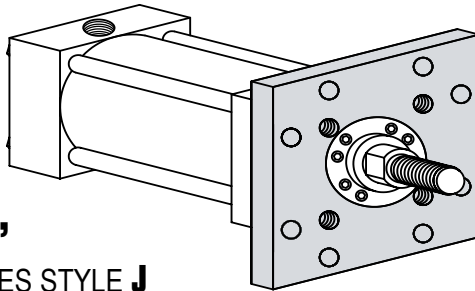

CAP RECTANGULAR FLANGE MOUNT

"R"

YATES STYLE **R**
NFPA-MF2

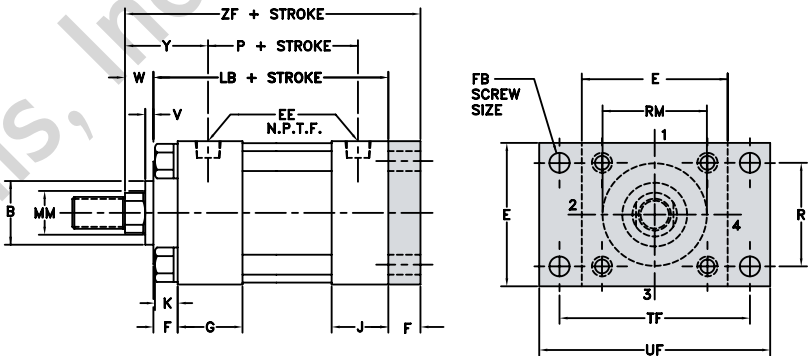
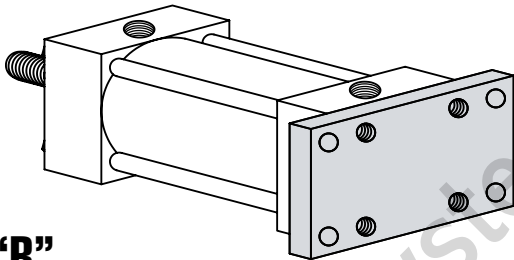

CAP SQUARE FLANGE MOUNT

"S"

YATES STYLE **S**
NFPA-MF6

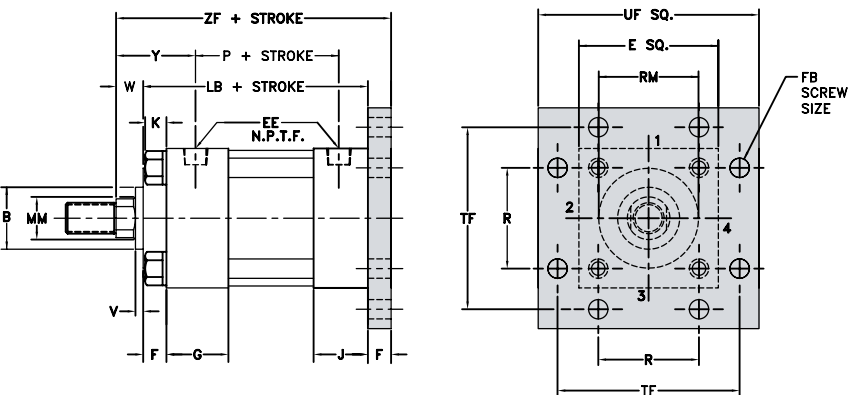
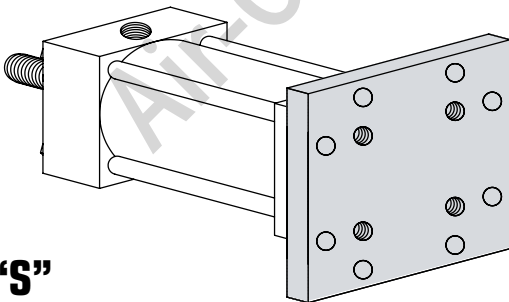

STANDARD ROD ENDS

#2 STD MALE NFPA-SM

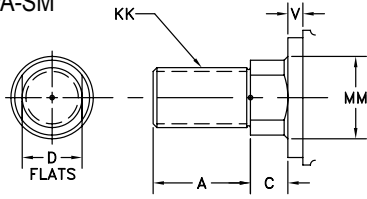

#4 STD FEMALE NFPA-SF

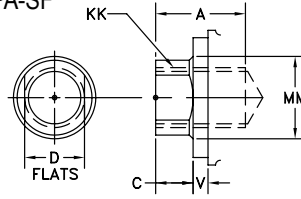

#1 MALE NFPA-IM

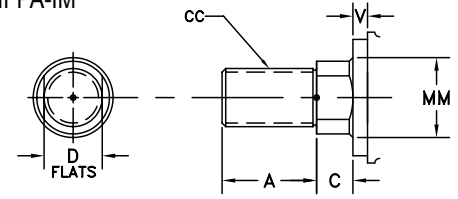

BORE	SAE											ADD STROKE	
	E	EE	OPT.	F	FB	G	J	K	R	TF	UF	LB	P
1 1/2	2 1/2	1/2	10	3/8	3/8	1 3/4	1 1/2	3/8	1.63	3 7/16	4 1/4	5	3
2	3	1/2	10	5/8	1/2	1 3/4	1 1/2	7/16	2.05	4 1/8	5 1/8	5 1/4	3
2 1/2	3 1/2	1/2	10	5/8	1/2	1 3/4	1 1/2	7/16	2.55	4 5/8	5 5/8	5 3/8	3 1/8
3 1/4	4 1/2	3/4	12	3/4	5/8	2	1 3/4	9/16	3.25	5 7/8	7 1/8	6 1/4	3 5/8
4	5	3/4	12	7/8	5/8	2	1 3/4	9/16	3.82	6 3/8	7 5/8	6 5/8	3 7/8
5	6 1/2	3/4	12	7/8	7/8	2	1 3/4	3/4	4.95	8 3/16	9 3/4	7 1/8	4 3/8
6	7 1/2	1	16	1	1	2 1/4	2 1/4	7/8	5.73	9 7/16	11 1/4	8 3/8	5
7	8 1/2	1 1/4	20	1	1 1/8	2 3/4	2 3/4	1	6.58	10 5/8	12 5/8	9 1/2	5 1/2
8	9 1/2	1 1/2	24	1	1 1/4	3	3	1 1/16	7.50	11 13/16	14	10 1/2	6 1/4

BORE	ROD DIA.	THREAD		ROD EXTENSIONS AND PILOT DIMENSIONS								ADD STROKE	"F" MOUNT	"R" MOUNT
		MM	KK	CC	A	B	C	D	V	W	RM	Y	ZF	MAX PSI PUSH
1 1/2	5/8	7/16-20	1/2-20	3/4	1 1/8	3/8	1/2	1/4	5/8	§	1 15/16	6	2500	3000
	1 †	3/4-16	7/8-14	1 1/8	1 1/2	1/2	7/8	1/2	1	§	2 5/16	6 3/8	1500	3000
2	1	3/4-16	7/8-14	1 1/8	1 1/2	1/2	7/8	1/4	3/4	§	2 5/16	6 5/8	2500	3000
	1 3/8 †	1-14	1 1/4-12	1 5/8	2	5/8	1 1/8	3/8	1	§	2 9/16	6 7/8	1500	3000
2 1/2	1	3/4-16	7/8-14	1 1/8	1 1/2	1/2	7/8	1/4	3/4	2 5/8	2 5/16	6 3/4	2500	3000
	1 3/8 †	1-14	1 1/4-12	1 5/8	2	5/8	1 1/8	3/8	1	§	2 9/16	7	1900	3000
	1 3/4 †	1 1/4-12	1 1/2-12	2	2 3/8	3/4	1 1/2	1/2	1 1/4	§	2 13/16	7 1/4	1500	3000
3 1/4	1 3/8	1-14	1 1/4-12	1 5/8	2	5/8	1 1/8	1/4	7/8	3 7/32	2 11/16	7 7/8	2500	3000
	1 3/4	1 1/4-12	1 1/2-12	2	2 3/8	3/4	1 1/2	3/8	1 1/8	§	2 15/16	8 1/8	2100	3000
	2 †	1 1/2-12	1 3/4-12	2 1/4	2 5/8	7/8	1 3/4	3/8	1 1/4	§	3 1/16	8 1/4	1500	3000
4	1 3/4	1 1/4-12	1 1/2-12	2	2 3/8	3/4	1 1/2	1/4	1	3 7/8	2 15/16	8 1/2	2500	3000
	2	1 1/2-12	1 3/4-12	2 1/4	2 5/8	7/8	1 3/4	1/4	1 1/8	4	3 1/16	8 5/8	1800	3000
	2 1/2	1 7/8-12	2 1/4-12	3	3 1/8	1	2 1/8	3/8	1 3/8	4 7/16	3 5/16	8 7/8	1500	3000
	2	1 1/2-12	1 3/4-12	2 1/4	2 5/8	7/8	1 3/4	1/4	1 1/8	4	3 1/16	9 1/8	2200	2000
5	2 1/2	1 7/8-12	2 1/4-12	3	3 1/8	1	2 1/8	3/8	1 3/8	4 7/16	3 5/16	9 3/8	1650	2500
	3	2 1/4-12	2 3/4-12	3 1/2	3 3/4	1	2 5/8	3/8	1 3/8	5 1/4	3 5/16	9 3/8	1200	2800
	3 1/2	2 1/2-12	3 1/4-12	3 1/2	4 1/4	1	3	3/8	1 3/8	5 5/8	3 5/16	9 3/8	750	3000
	2 1/2	1 7/8-12	2 1/4-12	3	3 1/8	1	2 1/8	1/4	1 1/4	4 7/16	3 7/16	10 5/8	1800	2000
6	3	2 1/4-12	2 3/4-12	3 1/2	3 3/4	1	2 5/8	1/4	1 1/4	5 1/4	3 7/16	10 5/8	1450	2500
	3 1/2	2 1/2-12	3 1/4-12	3 1/2	4 1/4	1	3	1/4	1 1/4	5 5/8	3 7/16	10 5/8	1100	2800
	4	3-12	3 3/4-12	4	4 3/4	1	Δ	1/4	1 1/4	§	3 7/16	10 5/8	750	3000
	3	2 1/4-12	2 3/4-12	3 1/2	3 3/4	1	2 5/8	1/4	1 1/4	5 1/4	3 7/16	10 5/8	1100	2800
7	3 1/2	2 1/2-12	3 1/4-12	3 1/2	4 1/4	1	3	1/4	1 1/4	5 1/4	3 3/4	11 3/4	740	1500
	4	3-12	3 3/4-12	4	4 3/4	1	Δ	1/4	1 1/4	5 5/8	3 3/4	11 3/4	650	1700
	4 1/2	3 1/4-12	4 1/4-12	4 1/2	5 1/4	1	Δ	1/4	1 1/4	6 7/16	3 3/4	11 3/4	450	1800
	5	3 1/2-12	4 3/4-12	5	5 3/4	1	Δ	1/4	1 1/4	7 1/8	3 3/4	11 3/4	360	1900
8	3 1/2	2 1/2-12	3 1/4-12	3 1/2	4 1/4	1	3	1/4	1 1/4	5 5/8	3 7/8	12 3/4	620	1500
	4	3-12	3 3/4-12	4	4 3/4	1	Δ	1/4	1 1/4	6 7/16	3 7/8	12 3/4	470	1700
	4 1/2	3 1/4-12	4 1/4-12	4 1/2	5 1/4	1	Δ	1/4	1 1/4	7 1/8	3 7/8	12 3/4	410	1800
	5	3 1/2-12	4 3/4-12	5	5 3/4	1	Δ	1/4	1 1/4	7 5/8	3 7/8	12 3/4	340	1900
	5 1/2	4-12	5 1/4-12	5 1/2	6 1/4	1	Δ	1/4	1 1/4	§	3 7/8	12 3/4	280	2000

† HEAD END PORTS SHALLOW TAPPED
 • CONSULT FACTORY FOR AVAILABILITY OF SAE PORT OPTION
 Δ (4) SPANNER HOLES USED INSTEAD OF FLATS ON 4" DIA. AND LARGER RODS

§ THESE CYLINDERS HAVE FULL PLATE RETAINERS. USE "E" DIMENSION INSTEAD OF "RM" - SEE PAGE 8
 ‡ B DIMENSION TOLERANCE -.001/-.003
NOTE: "F" AND "R" MOUNTS HAVE DERATED PRESSURE RATINGS, FOR HIGHER PRESSURE USE "G" AND "P" MOUNTS



HEAD RECTANGULAR INTEGRAL FLANGE MOUNT

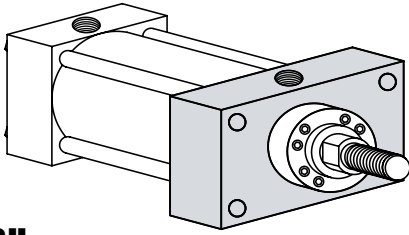

"G"
YATES STYLE **G**
NFPA-ME5

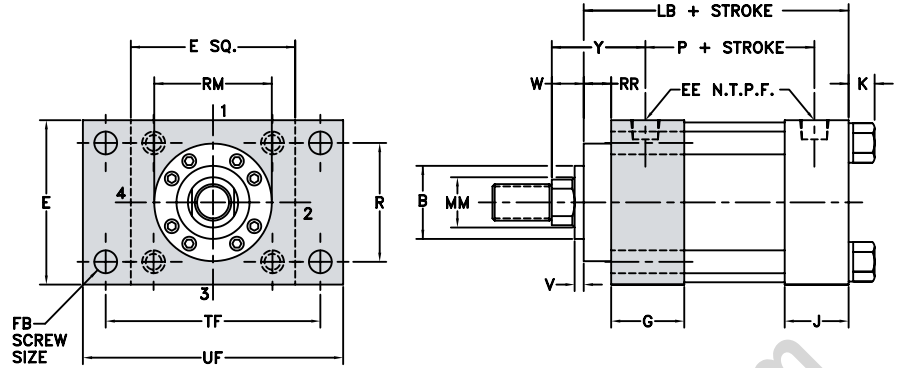

CAP RECTANGULAR INTEGRAL FLANGE MOUNT

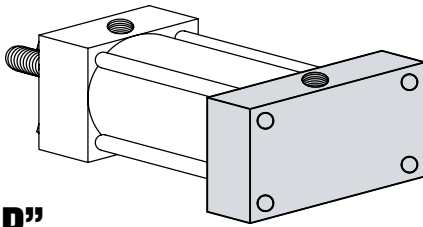

"P"
YATES STYLE **P**
NFPA-ME6

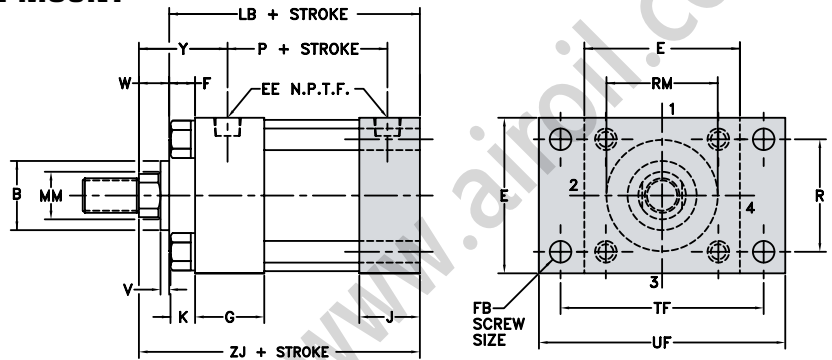

STANDARD ROD ENDS

#2 STD MALE
NFPA-SM

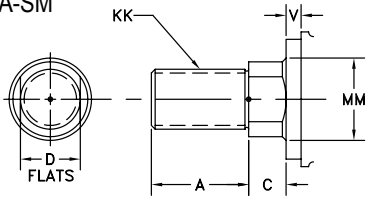

#4 STD FEMALE
NFPA-SF

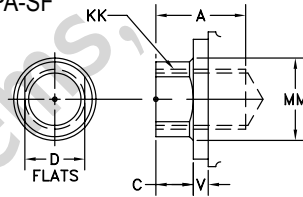

#1 MALE
NFPA-IM

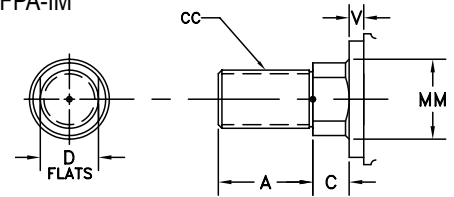

- † HEAD END PORTS SHALLOW TAPPED
- CONSULT FACTORY FOR AVAILABILITY OF SAE PORT OPTION
- Δ (4) SPANNER HOLES USED INSTEAD OF FLATS ON 4" DIA. AND LARGER RODS
- § P-MOUNT CYLINDERS HAVE FULL PLATE RETAINERS. USE "E" DIMENSION INSTEAD OF "RM" - SEE PAGE 8
- ‡ B DIMENSION TOLERANCE $-.001/-0.003$

BORE	SAE											ADD STROKE	
	E	EE	OPT	F	FB	G	J	K	R	TF	UF	LB	P
1 1/2	2 1/2	1/2	10	3/8	3/8	1 3/4	1 1/2	3/8	1.63	3 7/16	4 1/4	5	3
2	3	1/2	10	5/8	1/2	1 3/4	1 1/2	7/16	2.05	4 1/8	5 1/8	5 1/4	3
2 1/2	3 1/2	1/2	10	5/8	1/2	1 3/4	1 1/2	7/16	2.55	4 5/8	5 5/8	5 3/8	3 1/8
3 1/4	4 1/2	3/4	12	3/4	5/8	2	1 3/4	9/16	3.25	5 7/8	7 1/8	6 1/4	3 5/8
4	5	3/4	12	7/8	5/8	2	1 3/4	9/16	3.82	6 3/8	7 5/8	6 5/8	3 7/8
5	6 1/2	3/4	12	7/8	7/8	2	1 3/4	3/4	4.95	8 3/16	9 3/4	7 1/8	4 3/8
6	7 1/2	1	16	1	1	2 1/4	2 1/4	7/8	5.73	9 7/16	11 1/4	8 3/8	5
7	8 1/2	1 1/4	20	1	1 1/8	2 3/4	2 3/4	1	6.58	10 5/8	12 5/8	9 1/2	5 1/2
8	9 1/2	1 1/2	24	1	1 1/4	3	3	1 1/16	7.50	11 13/16	14	10 1/2	6 1/4
10	12 5/8	2	32	7/8	1 3/4	3 11/16	3 11/16	1	9.62	15 7/8	19	13	8 1/8
12	14 7/8	2 1/2	32	1 3/8	2	4 7/16	4 7/16	1 1/8	11.45	18 1/2	22	15 7/8	9 1/2
14	17 1/8	2 1/2	32	1 5/8	2 1/4	4 7/8	4 7/8	1 1/8	13.26	21	25	17 1/4	9 7/8

BORE	ROD DIA.	THREAD		ROD EXTENSIONS AND PILOT DIMENSIONS									ADD STROKE
	MM	KK	CC	A	B ‡	C	D	RR	V	W	RM	Y	ZJ
1 1/2	5/8	7/16-20	1/2-20	3/4	1 1/8	3/8	1/2	3/8	1/4	5/8	2 3/8 §	1 15/16	5 5/8
	1 †	3/4-16	7/8-14	1 1/8	1 1/2	1/2	7/8	1/2	1/2	1	2 5/8 §	2 5/16	6
2	1	3/4-16	7/8-14	1 1/8	1 1/2	1/2	7/8	5/8	1/4	3/4	2 5/8 §	2 5/16	6
	1 3/8 †	1-14	1 1/4-12	1 5/8	2	5/8	1 1/8	5/8	3/8	1	3 7/32 §	2 9/16	6 1/4
2 1/2	1	3/4-16	7/8-14	1 1/8	1 1/2	1/2	7/8	5/8	1/4	3/4	2 5/8	2 5/16	6 1/8
	1 3/8 †	1-14	1 1/4-12	1 5/8	2	5/8	1 1/8	5/8	3/8	1	3 7/32 §	2 9/16	6 3/8
	1 3/4 †	1 1/4-12	1 1/2-12	2	2 3/8	3/4	1 1/2	5/8	1/2	1 1/4	3 7/8 §	2 13/16	6 5/8
	1 3/8	1-14	1 1/4-12	1 5/8	2	5/8	1 1/8	5/8	1/4	7/8	3 7/32	2 11/16	7 1/8
3 1/4	1 3/4	1 1/4-12	1 1/2-12	2	2 3/8	3/4	1 1/2	5/8	3/8	1 1/8	3 7/8 §	2 15/16	7 3/8
	2 †	1 1/2-12	1 3/4-12	2 1/4	2 5/8	7/8	1 3/4	5/8	3/8	1 1/4	4 §	3 1/16	7 1/2
4	1 3/4	1 1/4-12	1 1/2-12	2	2 3/8	3/4	1 1/2	5/8	1/4	1	3 7/8	2 15/16	7 5/8
	2	1 1/2-12	1 3/4-12	2 1/4	2 5/8	7/8	1 3/4	5/8	1/4	1 1/8	4	3 1/16	7 3/4
	2 1/2	1 7/8-12	2 1/4-12	3	3 1/8	1	2 1/8	5/8	3/8	1 3/8	4 7/16	3 5/16	8
	2	1 1/2-12	1 3/4-12	2 1/4	2 5/8	7/8	1 3/4	5/8	1/4	1 1/8	4	3 1/16	8 1/4
5	2 1/2	1 7/8-12	2 1/4-12	3	3 1/8	1	2 1/8	5/8	3/8	1 3/8	4 7/16	3 5/16	8 1/2
	3	2 1/4-12	2 3/4-12	3 1/2	3 3/4	1	2 5/8	3/4	3/8	1 3/8	5 1/4	3 5/16	8 1/2
	3 1/2	2 1/2-12	3 1/4-12	3 1/2	4 1/4	1	3	3/4	3/8	1 3/8	5 5/8	3 5/16	8 1/2
	2 1/2	1 7/8-12	2 1/4-12	3	3 1/8	1	2 1/8	5/8	1/4	1 1/4	4 7/16	3 7/16	9 5/8
6	3	2 1/4-12	2 3/4-12	3 1/2	3 3/4	1	2 5/8	3/4	1/4	1 1/4	5 1/4	3 7/16	9 5/8
	3 1/2	2 1/2-12	3 1/4-12	3 1/2	4 1/4	1	3	3/4	1/4	1 1/4	5 5/8	3 7/16	9 5/8
7	4	3-12	3 3/4-12	4	4 3/4	1	Δ	7/8	1/4	1 1/4	6 7/16	3 7/16	9 5/8
	3	2 1/4-12	2 3/4-12	3 1/2	3 3/4	1	2 5/8	3/4	1/4	1 1/4	5 1/4	3 3/4	10 3/4
	3 1/2	2 1/2-12	3 1/4-12	3 1/2	4 1/4	1	3	3/4	1/4	1 1/4	5 5/8	3 3/4	10 3/4
	4	3-12	3 3/4-12	4	4 3/4	1	Δ	7/8	1/4	1 1/4	6 7/16	3 3/4	10 3/4
	4 1/2	3 1/4-12	4 1/4-12	4 1/2	5 1/4	1	Δ	7/8	1/4	1 1/4	7 1/8	3 3/4	10 3/4
	5	3 1/2-12	4 3/4-12	5	5 3/4	1	Δ	7/8	1/4	1 1/4	7 5/8	3 3/4	10 3/4
8	3 1/2	2 1/2-12	3 1/4-12	3 1/2	4 1/4	1	3	3/4	1/4	1 1/4	5 5/8	3 7/8	11 3/4
	4	3-12	3 3/4-12	4	4 3/4	1	Δ	7/8	1/4	1 1/4	6 7/16	3 7/8	11 3/4
	4 1/2	3 1/4-12	4 1/4-12	4 1/2	5 1/4	1	Δ	7/8	1/4	1 1/4	7 1/8	3 7/8	11 3/4
	5	3 1/2-12	4 3/4-12	5	5 3/4	1	Δ	7/8	1/4	1 1/4	7 5/8	3 7/8	11 3/4
	5 1/2	4-12	5 1/4-12	5 1/2	6 1/4	1	Δ	7/8	1/4	1 1/4	8 3/8	3 7/8	11 3/4
	4 1/2	3 1/4-12	4 1/4-12	4 1/2	5 1/4	1	Δ	7/8	1 1/16	2 1/16	7 1/8	4 15/16	15 1/16
10	5	3 1/2-12	4 3/4-12	5	5 3/4	1	Δ	7/8	1 5/16	2 5/16	7 5/8	5 3/16	15 5/16
	5 1/2	4-12	5 1/4-12	5 1/2	6 1/4	1	Δ	7/8	1 5/16	2 5/16	8 3/8	5 3/16	15 5/16
	7	5-12	6 1/2-12	7	8	1	Δ	7/8	1 5/8	2 5/8	10 7/8	5 1/2	15 5/8
	5 1/2	4-12	5 1/4-12	5 1/2	6 1/4	1	Δ	7/8	13/16	1 13/16	8 3/8	5 11/16	17 11/16
12	7	5-12	6 1/2-12	7	8	1	Δ	1 3/8	1 1/8	2 1/8	10 7/8	6	18
	8	5 3/4-12	7 1/2-12	8	9	1	Δ	1 3/8	1 5/8	2 5/8	12 3/8	6 1/2	18 1/2
14	7	5-12	6 1/2-12	7	8	1	Δ	1 5/8	7/8	1 7/8	10 13/16	6 3/8	19 1/8
	8	5 3/4-12	7 1/2-12	8	9	1	Δ	1 5/8	1 3/8	2 3/8	12 3/8	6 7/8	19 5/8
	9	6 1/2-12	8 1/2-12	9	10	1	Δ	1 5/8	1 5/8	2 5/8	13 1/8	7 1/8	19 7/8
	10	7 1/4-12	9 1/2-12	10	11	1	Δ	1 5/8	1 7/8	2 7/8	14 5/8	7 3/8	20 1/8



HEAD SQUARE INTEGRAL FLANGE MOUNT

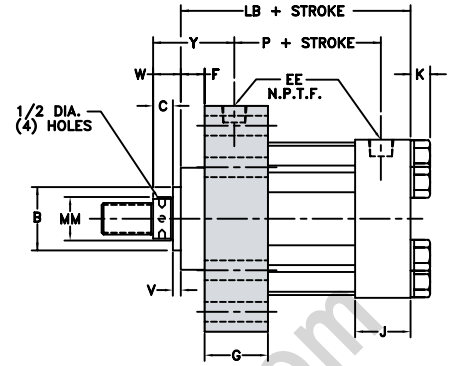
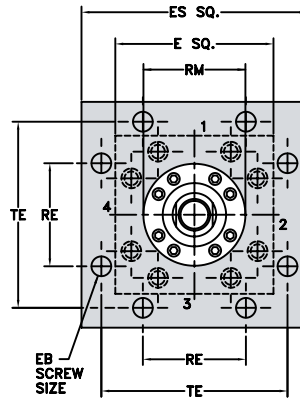
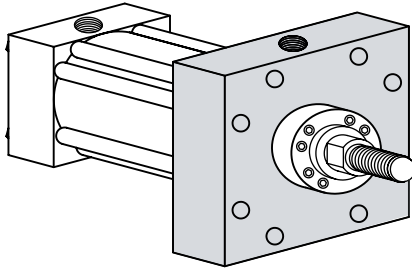

“X”
YATES STYLE **X**
NFPA-ME3

CAP SQUARE INTEGRAL FLANGE MOUNT

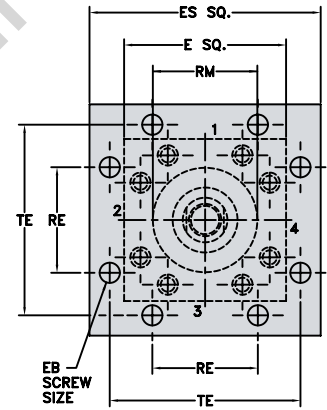
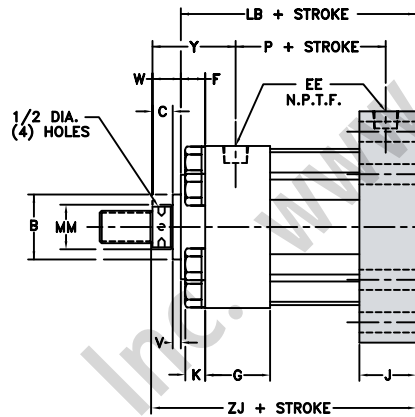
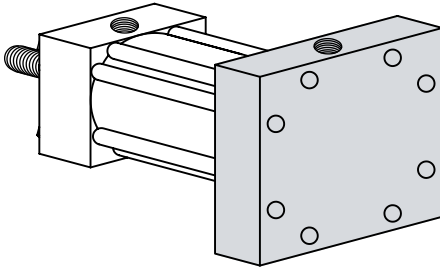

“Z”
YATES STYLE **Z**
NFPA-ME4

STANDARD ROD ENDS

#2 STD MALE NFPA-SM

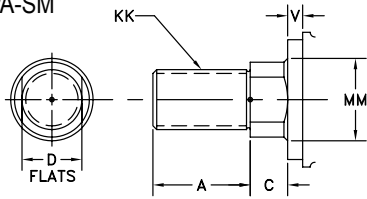

#4 STD FEMALE NFPA-SF

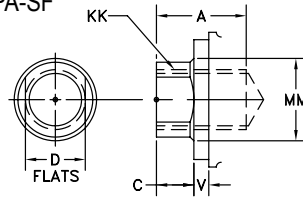

#1 MALE NFPA-IM

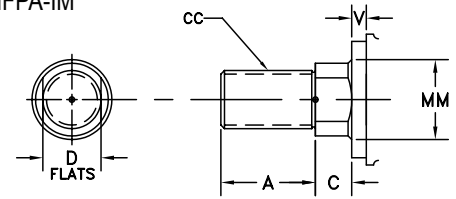

BORE	E	EB	EE	SAE OPT	F	ES	G	J	K	RE	TE	ADD STROKE	
												LB	P
10	12 5/8	1 1/4	2	32	7/8	16 5/8	3 11/16	3 11/16	1	9 7/8	14 1/8	13	8 1/8
12	14 7/8	1 1/2	2 1/2	32	1 3/8	19 3/4	4 7/16	4 7/16	1 1/16	11 3/4	16 3/4	15 7/8	9 1/2
14	17 1/8	1 3/4	2 1/2	32	1 5/8	21 3/4	4 7/8	4 7/8	1 1/16	12 15/16	18 7/16	17 1/4	9 7/8
16	19 1/4	1 3/4	3	32	1 7/8	24 1/2	5 7/8	5 7/8	1 9/32	15 1/4	21 1/16	20	11
18	22	2	3	32	2 3/16	26 1/2	6 7/8	6 7/8	1 9/32	16 7/16	22 5/8	23 5/16	12
20	23 5/8	2	3	32	2 11/16	29	7 7/8	7 7/8	1 9/32	18 1/16	24 7/8	26 5/16	12 1/2

BORE	ROD DIA.	THREAD		ROD EXTENSIONS AND PILOT DIMENSIONS								ADD STROKE
	MM	KK	CC	A	B ±	C	D	V	W	RM	Y	ZJ
10	4 1/2	3 1/4-12	4 1/4-12	4 1/2	5 1/4	1	Δ	1 1/16	2 1/16	7 1/8	4 15/16	15 1/16
	5	3 1/2-12	4 3/4-12	5	5 3/4	1	Δ	1 5/16	2 5/16	7 5/8	5 3/16	15 5/16
	5 1/2	4-12	5 1/4-12	5 1/2	6 1/4	1	Δ	1 5/16	2 5/16	8 3/8	5 3/16	15 5/16
12	7	5-12	6 1/2-12	7	8	1	Δ	1 5/8	2 5/8	10 7/8	5 1/2	15 5/8
	5 1/2	4-12	5 1/4-12	5 1/2	6 1/4	1	Δ	13/16	1 13/16	8 3/8	5 11/16	17 11/16
	7	5-12	6 1/2-12	7	8	1	Δ	1 1/8	2 1/8	10 7/8	6	18
14	8	5 3/4-12	7 1/2-12	8	9	1	Δ	1 5/8	2 5/8	12 3/8	6 1/2	18 1/2
	7	5-12	6 1/2-12	7	8	1	Δ	7/8	1 7/8	10 13/16	6 3/8	19 1/8
	8	5 3/4-12	7 1/2-12	8	9	1	Δ	1 3/8	2 3/8	12 3/8	6 7/8	19 5/8
16	9	6 1/2-12	8 1/2-12	9	10	1	Δ	1 5/8	2 5/8	13 1/8	7 1/8	19 7/8
	10	7 1/4-12	9 1/2-12	10	11	1	Δ	1 7/8	2 7/8	14 5/8	7 3/8	20 1/8
	8	5 3/4-12	7 1/2-12	8	9	1	Δ	1 1/8	2 1/8	12 3/8	7 9/16	22 1/8
18	9	6 1/2-12	8 1/2-12	9	10	1	Δ	1 3/8	2 3/8	13 1/8	7 13/16	22 3/8
	10	7 1/4-12	9 1/2-12	10	11	1	Δ	1 5/8	2 5/8	14 5/8	8 1/16	22 5/8
	9	6 1/2-12	8 1/2-12	9	10	1	Δ	1 1/16	2 1/16	13 1/8	8 13/16	25 3/8
20	10	7 1/4-12	9 1/2-12	10	11	1	Δ	1 5/16	2 5/16	14 5/8	9 1/16	25 5/8
	10	7 1/4-12	9 1/2-12	10	11	1	Δ	13/16	1 13/16	14 5/8	10 1/16	28 1/8

Δ (4) SPANNER HOLES USED INSTEAD OF FLATS ON 4" DIA. AND LARGER RODS

± B DIMENSION TOLERANCE -.001/-.003

NOTE: SEE PAGE 8 FOR TIE ROD INFORMATION ON 10" THRU 20" BORES



NO TIE RODS EXTENDED MOUNT

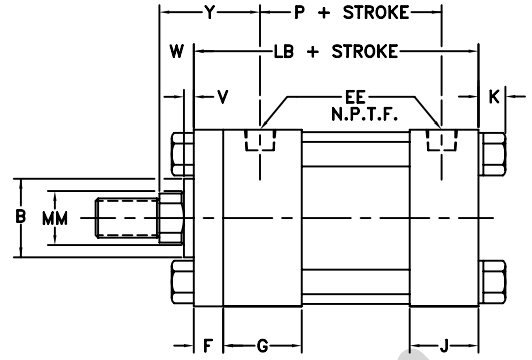
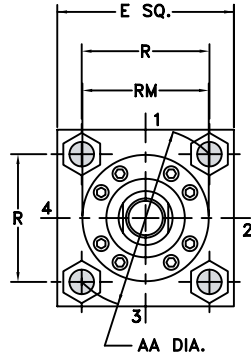
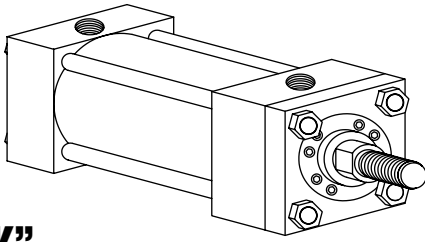

“K”

YATES STYLE **K**
NFPA-MX0

BOTH ENDS TIE RODS EXTENDED MOUNT

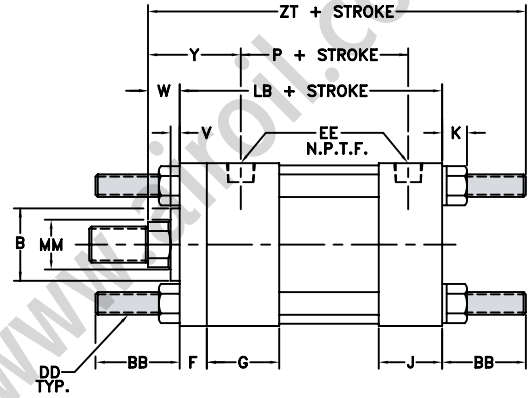
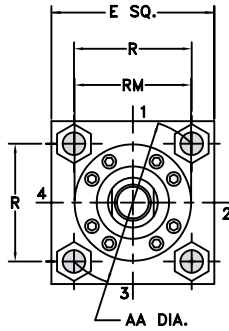
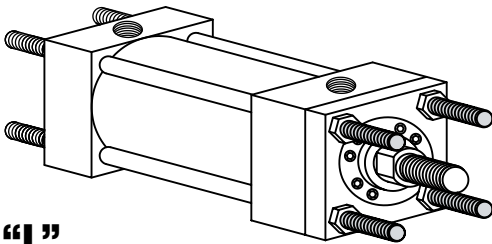

“L”

YATES STYLE **L**
NFPA-MX1

HEAD TIE RODS EXTENDED MOUNT

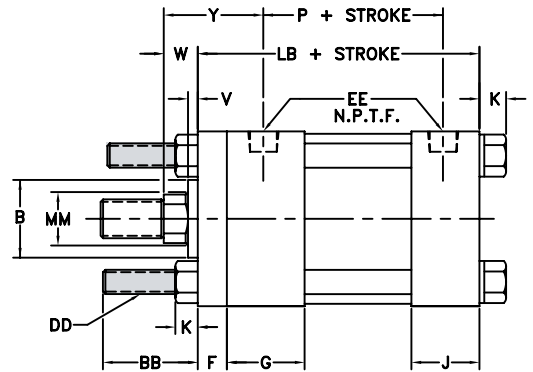
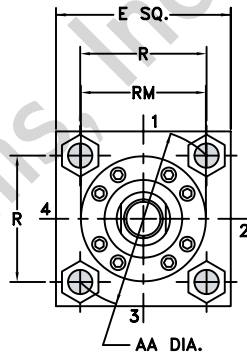
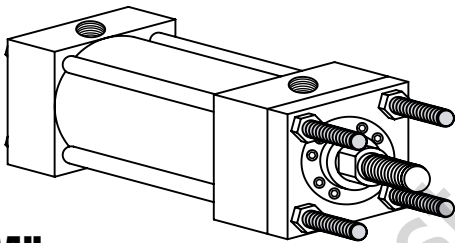

“M”

YATES STYLE **M**
NFPA-MX3

CAP TIE RODS EXTENDED MOUNT

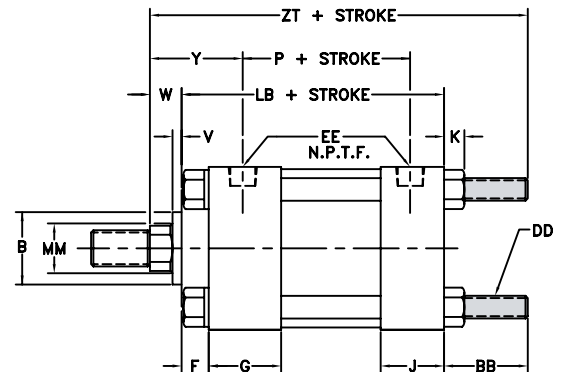
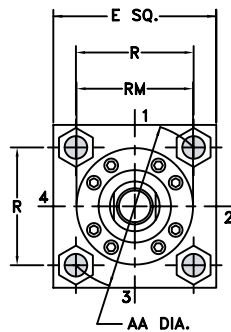
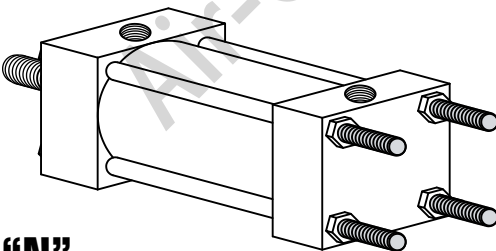

“N”

YATES STYLE **N**
NFPA-MX2

STANDARD ROD ENDS

#2 STD MALE NFPA-SM

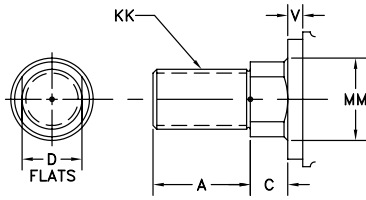

#4 STD FEMALE NFPA-SF

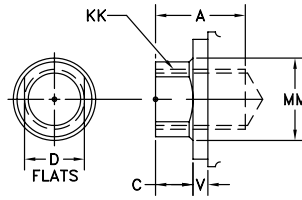

#1 MALE NFPA-IM

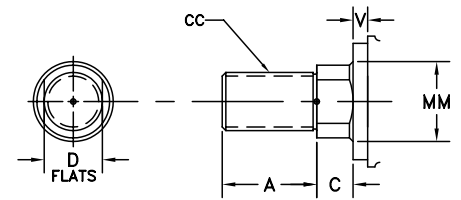

BORE	AA	BB	DD	E	EE	SAE OPT.	F	G	J	K	R	ADD STROKE	
												LB	P
1 1/2	2.3	1 3/8	3/8-24	2 1/2	1/2	10	3/8	1 3/4	1 1/2	3/8	1.63	5	3
2	2.9	1 13/16	1/2-20	3	1/2	10	5/8	1 3/4	1 1/2	7/16	2.05	5 1/4	3
2 1/2	3.6	1 13/16	1/2-20	3 1/2	1/2	10	5/8	1 3/4	1 1/2	7/16	2.55	5 3/8	3 1/8
3 1/4	4.6	2 5/16	5/8-18	4 1/2	3/4	12	3/4	2	1 3/4	9/16	3.25	6 1/4	3 5/8
4	5.4	2 5/16	5/8-18	5	3/4	12	7/8	2	1 3/4	9/16	3.82	6 5/8	3 7/8
5	7.0	3 3/16	7/8-14	6 1/2	3/4	12	7/8	2	1 3/4	3/4	4.95	7 1/8	4 3/8
6	8.1	3 5/8	1-14	7 1/2	1	16	1	2 1/4	2 1/4	7/8	5.73	8 3/8	5
7	9.3	4 1/8	1 1/8-12	8 1/2	1 1/4	20	1	2 3/4	2 3/4	1	6.58	9 1/2	5 1/2
8	10.6	4 1/2	1 1/4-12	9 1/2	1 1/2	24	1	3	3	1 1/16	7.50	10 1/2	6 1/4

BORE	ROD DIA.	THREAD		ROD EXTENSIONS AND PILOT DIMENSION								ADD STROKE
	MM	KK	CC	A	B	C	D	V	W	RM	Y	ZT*
1 1/2	5/8	7/16-20	1/2-20	3/4	1 1/8	3/8	1/2	1/4	5/8	§	1 15/16	7
	1 †	3/4-16	7/8-14	1 1/8	1 1/2	1/2	7/8	1/2	1	§	2 5/16	7 3/8
2	1	3/4-16	7/8-14	1 1/8	1 1/2	1/2	7/8	1/4	3/4	§	2 5/16	7 13/16
	1 3/8 †	1-14	1 1/4-12	1 5/8	2	5/8	1 1/8	3/8	1	§	2 9/16	8 1/16
2 1/2	1	3/4-16	7/8-14	1 1/8	1 1/2	1/2	7/8	1/4	3/4	2 5/8	2 5/16	7 15/16
	1 3/8 †	1-14	1 1/4-12	1 5/8	2	5/8	1 1/8	3/8	1	§	2 9/16	8 3/16
3 1/4	1 3/8 †	1 1/4-12	1 1/2-12	2	2 3/8	3/4	1 1/2	1/2	1 1/4	§	2 13/16	8 7/16
	1 3/4	1-14	1 1/4-12	1 5/8	2	5/8	1 1/8	1/4	7/8	3 7/32	2 11/16	9 7/16
4	1 3/8	1 1/4-12	1 1/2-12	2	2 3/8	3/4	1 1/2	3/8	1 1/8	§	2 15/16	9 11/16
	2 †	1 1/2-12	1 3/4-12	2 1/4	2 5/8	7/8	1 3/4	3/8	1 1/4	§	3 1/16	9 13/16
5	1 3/4	1 1/4-12	1 1/2-12	2	2 3/8	3/4	1 1/2	1/4	1	3 7/8	2 15/16	9 15/16
	2	1 1/2-12	1 3/4-12	2 1/4	2 5/8	7/8	1 3/4	1/4	1 1/8	4	3 1/16	10 1/16
6	2 1/2	1 7/8-12	2 1/4-12	3	3 1/8	1	2 1/8	3/8	1 3/8	4 7/16	3 5/16	10 5/16
	2	1 1/2-12	1 3/4-12	2 1/4	2 5/8	7/8	1 3/4	1/4	1 1/8	4	3 1/16	11 7/16
7	2 1/2	1 7/8-12	2 1/4-12	3	3 1/8	1	2 1/8	3/8	1 3/8	4 7/16	3 5/16	11 11/16
	3	2 1/4-12	2 3/4-12	3 1/2	3 3/4	1	2 5/8	3/8	1 3/8	5 1/4	3 5/16	11 11/16
8	3 1/2	2 1/2-12	3 1/4-12	3 1/2	4 1/4	1	3	3/8	1 3/8	5 5/8	3 5/16	11 11/16
	2 1/2	1 7/8-12	2 1/4-12	3	3 1/8	1	2 1/8	1/4	1 1/4	4 7/16	3 7/16	13 1/4
9	3	2 1/4-12	2 3/4-12	3 1/2	3 3/4	1	2 5/8	1/4	1 1/4	4 7/16	3 7/16	13 1/4
	3 1/2	2 1/2-12	3 1/4-12	3 1/2	4 1/4	1	3	1/4	1 1/4	5 1/4	3 7/16	13 1/4
10	4	3-12	3 3/4-12	4	4 3/4	1	Δ	1/4	1 1/4	6 7/16	3 7/16	13 1/4
	3	2 1/4-12	2 3/4-12	3 1/2	3 3/4	1	2 5/8	1/4	1 1/4	5 1/4	3 3/4	14 7/8
11	3 1/2	2 1/2-12	3 1/4-12	3 1/2	4 1/4	1	3	1/4	1 1/4	5 5/8	3 3/4	14 7/8
	4	3-12	3 3/4-12	4	4 3/4	1	Δ	1/4	1 1/4	6 7/16	3 3/4	14 7/8
12	4 1/2	3 1/4-12	4 1/4-12	4 1/2	5 1/4	1	Δ	1/4	1 1/4	7 1/8	3 3/4	14 7/8
	5	3 1/2-12	4 3/4-12	5	5 3/4	1	Δ	1/4	1 1/4	7 5/8	3 3/4	14 7/8
13	3 1/2	2 1/2-12	3 1/4-12	3 1/2	4 1/4	1	3	1/4	1 1/4	5 5/8	3 7/8	16 1/4
	4	3-12	3 3/4-12	4	4 3/4	1	Δ	1/4	1 1/4	6 7/16	3 7/8	16 1/4
14	4 1/2	3 1/4-12	4 1/4-12	4 1/2	5 1/4	1	Δ	1/4	1 1/4	7 1/8	3 7/8	16 1/4
	5	3 1/2-12	4 3/4-12	5	5 3/4	1	Δ	1/4	1 1/4	7 5/8	3 7/8	16 1/4
15	5 1/2	4-12	5 1/4-12	5 1/2	6 1/4	1	Δ	1/4	1 1/4	8 3/8	3 7/8	16 1/4

† HEAD END PORTS SHALLOW TAPPED
 † CONSULT FACTORY FOR AVAILABILITY OF SAE PORT OPTION
 Δ (4) SPANNER HOLES USED INSTEAD OF FLATS ON 4" DIA. AND LARGER RODS
 ‡ B DIMENSION TOLERANCE -.001/- .003
 § THESE CYLINDERS HAVE FULL PLATE RETAINERS. USE "E" DIMENSION INSTEAD OF "RM" - SEE PAGE 8
 * ZT DIMENSION CHANGES ON DOUBLE ROD CYLINDERS - SEE PAGE 33 FOR DETAILS
NOTE: 1 1/2" AND 2" BORE CYLINDERS ON K AND N MOUNTS AND 1 1/2" THRU 8" BORE CYLINDERS ON L AND M MOUNTS HAVE FULL PLATE RETAINERS. USE "E" SQ. DIMENSION INSTEAD OF RM



DOUBLE ROD END STYLES

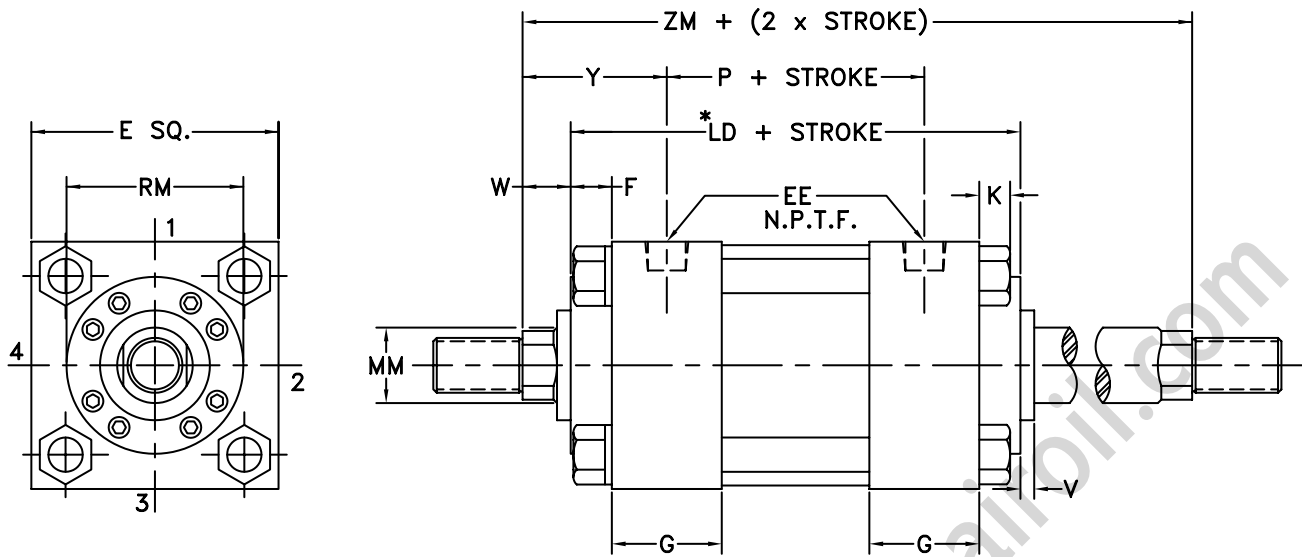

AVAILABLE IN MOUNTING STYLES A, B, E, F, G, H, J, K, L, M, T, U, AND X

FOR ORDERING DOUBLE ROD END CYLINDERS ADD "D" AFTER STYLE

Example: Style "A" side lug mount with double rod end is style "HGAD"

Where the two rod ends will be different, state which rod end is to go at which end of cylinder.

If only one end of double rod cylinder is to be cushioned, specify clearly which end.

EXTENDED KEY PLATE MOUNTINGS

BORE	FA	FE
1 1/2	.362	3/16
2	.612	5/16
2 1/2	.612	5/16
3 1/4	.737	3/8
4	.862	7/16
5	.862	7/16
6	.987	1/2
7	.987	1/2
8	.987	1/2

FOR ORDERING EXTENDED KEY PLATE add "S" in part # & state extended key plate in description.

AVAILABLE IN MOUNTING STYLES "A", "B", AND "E"

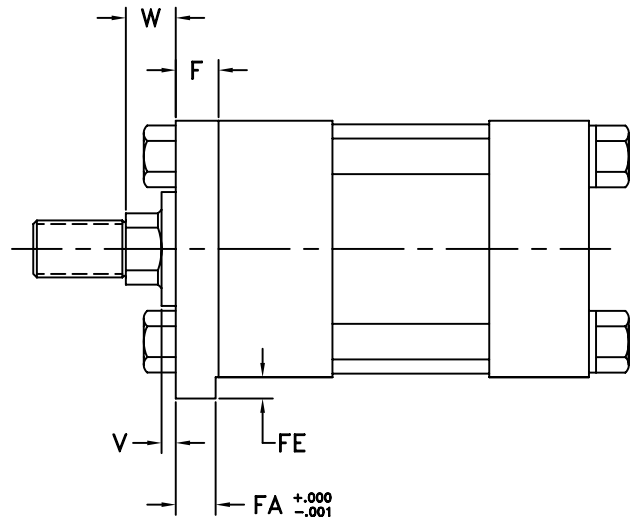

DOUBLE ROD END DIMENSIONS

BORE	ROD DIA.		ADD STROKE					ADD 2X STROKE
	MM	LD*	SED	SSD	XED	ZED	ZTD	ZM
1 1/2	5/8	5 5/8	7 3/8	4 1/8	7 1/8	7 1/2	7 5/8	6 7/8
	1	5 5/8	7 3/8	4 1/8	7 1/2	7 7/8	8	7 5/8
2	1	6 1/8	8	3 7/8	7 13/16	8 5/16	8 11/16	7 5/8
	1 3/8	6 1/8	8	3 7/8	8 1/16	8 9/16	8 15/16	8 1/8
2 1/2	1	6 1/4	8 1/8	3 5/8	8 15/16	8 7/16	8 13/16	7 3/4
	1 3/8	6 1/4	8 1/8	3 5/8	8 3/16	8 11/16	9 1/16	8 1/4
	1 3/4	6 1/4	8 1/8	3 5/8	8 7/16	8 15/16	9 5/16	8 3/4
3 1/4	1 3/8	7 1/4	9 1/2	4 3/8	9 1/4	9 7/8	10 7/16	9
	1 3/4	7 1/4	9 1/2	4 3/8	9 1/2	10 1/8	10 11/16	9 1/2
	2 †	7 1/4	9 1/2	4 3/8	9 5/8	10 1/4	10 13/16	9 3/4
4	1 3/4	7 3/4	10	4 1/4	9 7/8	10 1/2	11 1/16	9 3/4
	2	7 3/4	10	4 1/4	10	10 5/8	11 3/16	10
	2 1/2	7 3/4	10	4 1/4	10 1/4	10 7/8	11 7/16	10 1/2
5	2	8 1/4	11 1/4	4 3/4	10 7/8	11 5/16	12 9/16	10 1/2
	2 1/2	8 1/4	11 1/4	4 3/4	11 1/8	11 7/8	12 13/16	11
	3	8 1/4	11 1/4	4 3/4	11 1/8	11 7/8	12 13/16	11
	3 1/2	8 1/4	11 1/4	4 3/4	11 1/8	11 7/8	12 13/16	11
6	2 1/2	9 3/8	12 3/4	5 1/8	12 5/16	13 3/16	14 1/4	11 7/8
	3	9 3/8	12 3/4	5 1/8	12 5/16	13 3/16	14 1/4	11 7/8
	3 1/2	9 3/8	12 3/4	5 1/8	12 5/16	13 3/16	14 1/4	11 7/8
	4	9 3/8	12 3/4	5 1/8	12 5/16	13 3/16	14 1/4	11 7/8
7	3	10 1/2	14 1/8	5 3/4	13 9/16	14 9/16	15 7/8	13
	3 1/2	10 1/2	14 1/8	5 3/4	13 9/16	14 9/16	15 7/8	13
	4	10 1/2	14 1/8	5 3/4	13 9/16	14 9/16	15 7/8	13
	4 1/2	10 1/2	14 1/8	5 3/4	13 9/16	14 9/16	15 7/8	13
	5	10 1/2	14 1/8	5 3/4	13 9/16	14 9/16	15 7/8	13
8	3 1/2	11 1/2	15 1/2	6 3/4	14 3/4	15 7/8	17 1/4	14
	4	11 1/2	15 1/2	6 3/4	14 3/4	15 7/8	17 1/4	14
	4 1/2	11 1/2	15 1/2	6 3/4	14 3/4	15 3/8	17 1/4	14
	5	11 1/2	15 1/2	6 3/4	14 3/4	15 7/8	17 1/4	14
	5 1/2	11 1/2	15 1/2	6 3/4	14 3/4	15 7/8	17 1/4	14
10	4 1/5	14	NA	NA	NA	NA	NA	15 15/16
	5	14	NA	NA	NA	NA	NA	16 7/16
	5 1/2	14	NA	NA	NA	NA	NA	16 7/16
	7	14	NA	NA	NA	NA	NA	17 1/16

BORE	ROD DIA.		ADD STROKE					ADD 2X STROKE
	MM	LD*	SED	SSD	XED	ZED	ZTD	ZM
12	5 1/2	17 1/4	NA	NA	NA	NA	NA	19 1/16
	7	17 1/4	NA	NA	NA	NA	NA	19 11/16
	8	17 1/4	NA	NA	NA	NA	NA	20 11/16
14	7	18 7/8	NA	NA	NA	NA	NA	20 3/4
	8	18 7/8	NA	NA	NA	NA	NA	21 3/4
	9	18 7/8	NA	NA	NA	NA	NA	22 1/4
	10	18 7/8	NA	NA	NA	NA	NA	22 3/4
16	8	21 7/8	NA	NA	NA	NA	NA	24
	9	21 7/8	NA	NA	NA	NA	NA	24 1/4
	10	21 7/8	NA	NA	NA	NA	NA	25
18	9	25 1/2	NA	NA	NA	NA	NA	27 9/16
	10	25 1/2	NA	NA	NA	NA	NA	28 1/16
20	10	29	NA	NA	NA	NA	NA	30 13/16



FEMALE CLEVIS

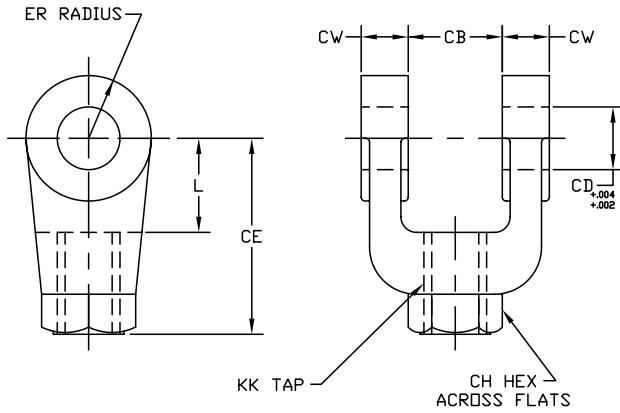

PART NO.	CB	CD	CE	CH	CW	ER	KK	L
10-YFC-134-05-A	3/4	1/2	1 1/2	1	1/2	1/2	7/16-20	3/4
10-YFC-134-08-A	1 1/4	3/4	2 3/8	1 1/4	5/8	3/4	3/4-16	1 1/4
10-YFC-134-08-M	1 1/4	3/4	2 1/8	1 3/8	5/8	3/4	3/4-16	1
10-YFC-134-11-A	1 1/2	1	3 1/8	1 1/2	3/4	1	1-14	1 1/2
10-YFC-134-11-M	1 1/2	1	2 15/16	1 1/2	3/4	1	1-14	1 5/16
10-YFC-134-14-A	2	1 3/8	4 1/8	2	1	1 3/8	1 1/4-12	2 1/8
10-YFC-134-14-M	2	1 3/8	3 3/4	2	1	1 3/8	1 1/4-12	1 3/4
10-YFC-134-16-A	2 1/2	1 3/4	4 1/2	2 3/8	1 1/4	1 3/4	1 1/2-12	2 1/4
10-YFC-134-20-A	2 1/2	2	5 1/2	2 15/16	1 1/4	2	1 7/8-12	2 1/2
10-YFC-134-24-A	3	2 1/2	6 1/2	3 1/2	1 1/2	2 1/2	2 1/4-12	3
10-YFC-134-28-A	3	3	6 3/4	3 7/8	1 1/2	2 3/4	2 1/2-12	3 1/4
10-YFC-134-28-M	3	3	6 3/4	3 7/8	1 1/2	3	2 1/2-12	3 1/4
10-YFC-134-36-A	4	3 1/2	8 1/2	5	2	3 1/2	3 1/4-12	4
10-YFC-134-36-M	4	3 1/2	7 3/4	5	2	3 1/2	3 1/4-12	4 1/4
10-YFC-134-44-A	4 1/2	4	10	6 1/8	2 1/4	4	4-12	4 1/2

ROD COUPLERS

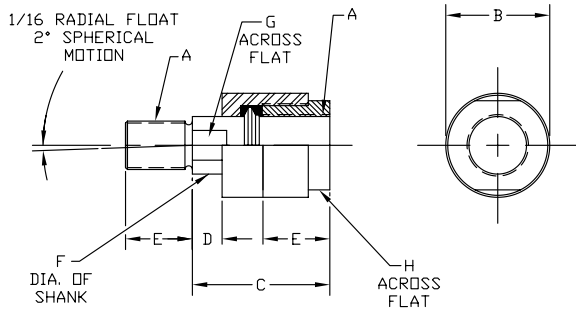

PART NUMBER	ROD DIA.	A	B	C	D	E	F	G	H	MAX PULL
11-YAC-2-05	5/8	7/16-20	1 1/4	2	1/2	3/4	5/8	1/2	1	10,000
11-YAC-2-06	5/8	1/2-20	1 1/4	2	1/2	3/4	5/8	1/2	1	14,000
11-YAC-2-07	5/8	5/8-18	1 1/4	2	1/2	3/4	5/8	1/2	1	19,000
11-YAC-2-08	1	3/4-16	1 3/4	2 5/16	1/2	1 1/8	31/32	13/16	1 1/2	34,000
11-YAC-2-09	1	7/8-14	1 3/4	2 5/16	1/2	1 1/8	31/32	13/16	1 1/2	39,000
11-YAC-2-11	1 3/8	1-14	2 1/2	2 15/16	1/2	1 5/8	1 3/8	1 5/32	2 1/4	64,000
11-YAC-2-14	1 3/8	1 1/4-12	2 1/2	2 15/16	1/2	1 5/8	1 3/8	1 5/32	2 1/4	78,000
11-YAC-2-15	1 3/8	1 3/8-12	2 1/2	2 15/16	1/2	1 5/8	1 3/8	1 5/32	2 1/4	78,000
11-YAC-2-16	2	1 1/2-12	3 1/4	4 3/8	13/16	2 1/4	1 3/4	1 1/2	3	134,000
11-YAC-2-17	2	1 3/4-12	3 1/4	4 3/8	13/16	2 1/4	1 3/4	1 1/2	3	134,000
11-YAC-2-20	2 1/2	1 7/8-12	3 3/4	5 7/16	7/8	3	2	1 7/8	3 1/2	240,000
11-YAC-2-21	2 1/2	2-12	3 3/4	5 7/16	7/8	3	2	1 7/8	3 1/2	240,000
11-YAC-2-24	3	2 1/4-12	6 3/4	6 3/8	1	3 1/2	2 3/4	2 3/8	4 1/2	397,000
11-YAC-2-28	3 1/2	2 1/2-12	7	6 1/2	1	3 1/2	3 1/4	2 7/8	3 3/8	495,000
11-YAC-2-29	3 1/2	2 3/4-12	7	6 1/2	1	3 1/2	3 1/4	2 7/8	3 3/8	603,000
11-YAC-2-36	4 1/2	3 1/4-12	9 1/4	8 1/2	5 1/4	4 1/2	4	3 3/8	4 1/2	853,800
11-YAC-2-37	4 1/2	4 1/4-12	12 7/8	11 1/4	7 3/4	4 1/2	5 1/2	4 7/8	7	1,483,400

CLEVIS BRACKET

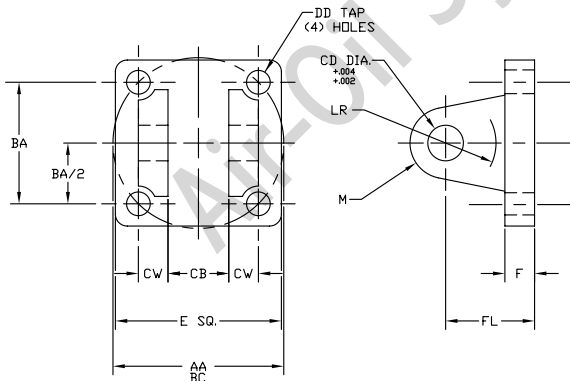

PART NUMBER	AA	BA	CB	CD	CW	DD	E	F	FL	LR	M
14-YCB-133-03	2.3	1 5/8	25/32	1/2	1/2	5/8-24	2 1/2	3/8	1 1/8	1/2	1/2
14-YCB-133-04	2.9	2 1/16	1 9/32	3/4	5/8	1/2-20	3	5/8	1 7/8	1	3/4
14-YCB-133-05	3.6	2 9/16	1 9/32	3/4	5/8	1/2-20	3 1/2	5/8	1 7/8	1 1/16	3/4
14-YCB-133-06	4.6	3 1/4	1 17/32	1	3/4	5/8-18	4 1/2	3/4	2 1/4	1 1/4	1
14-YCB-133-08	5.4	3 13/16	2 1/32	1 3/8	1	5/8-18	5	7/8	3	1 7/8	1 3/8
14-YCB-133-10	7.0	4 15/16	2 17/32	1 3/4	1 1/4	7/8-14	6 1/2	7/8	3 1/8	2	1 3/4
14-YCB-133-12	8.1	5 3/4	2 17/32	2	1 1/4	1-14	7 1/2	1	3 1/2	2 1/8	2
14-YCB-133-14	9.3	6 19/32	3 1/32	2 1/2	1 1/2	1 1/8-12	8 1/2	1	4	2 5/8	2 1/2
14-YCB-133-16	10.6	7 1/2	3 1/32	3	1 1/2	1 1/4-12	9 1/2	1	4 1/4	2 7/8	2 3/4
14-YCB-133-20	13.6	9 5/8	4 1/16	3 1/2	2	1 3/4-12	12 5/8	1 11/16	5 11/16	3 5/8	3 1/2
14-YCB-133-24	16.2	11 1/2	4 9/16	4	2 1/4	2-12	14 7/8	1 15/16	6 7/16	4	4



FEMALE EYE

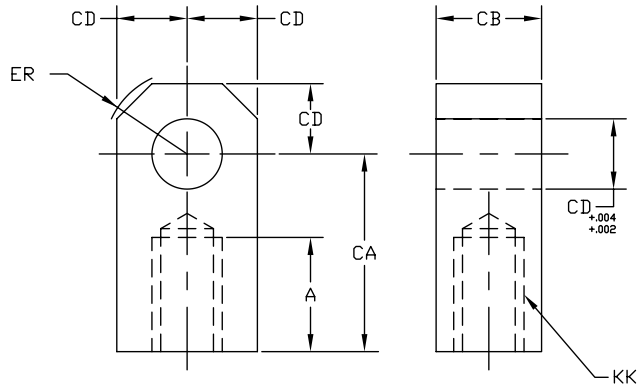

PART NUMBER	A	CA	CB	CD	ER	KK
13-YE-9303	3/4	1/2	3/4	1/2	5/8	7/16-20
13-YE-9304	1 1/8	2 1/16	1 1/4	3/4	7/8	3/4-16
13-YE-9306	1 5/8	2 13/16	1 1/2	1	1 3/16	1-14
13-YE-9306-M	1 1/8	2 3/8	1 1/2	1	1 7/16	7/8-14
13-YE-9308	2	3 7/16	2	1 3/8	1 9/16	1 1/4-12
13-YE-9310	2 1/4	4	2 1/2	1 3/4	2	1 1/2-12
13-YE-9312	3	5	2 1/2	2	2 1/2	1 7/8-12
13-YE-9312-M	2 1/4	4 3/8	2 1/2	2	2 7/8	1 3/4-12
13-YE-9314	3 1/2	5 13/16	3	2 1/2	2 13/16	2 1/4-12
13-YE-9316	3 1/2	6 1/8	3	3	3 1/4	2 1/2-12
13-YE9316-M	3 5/8	6 1/2	3 1/2	3	3 1/4	2 3/4-12
13-YE-9320	4 1/2	7 5/8	4	3 1/2	3 7/8	3 1/4-12
13-YE-9320-M	5	7 5/8	4	3 1/2	3 7/8	3 1/2-12
13-YE-9324	5 1/2	9 1/8	4 1/2	4	4 7/16	4-12
13-YE-9324-M	5 3/4	9 1/8	5	4	4 7/16	4 1/2-12

PIVOT PIN

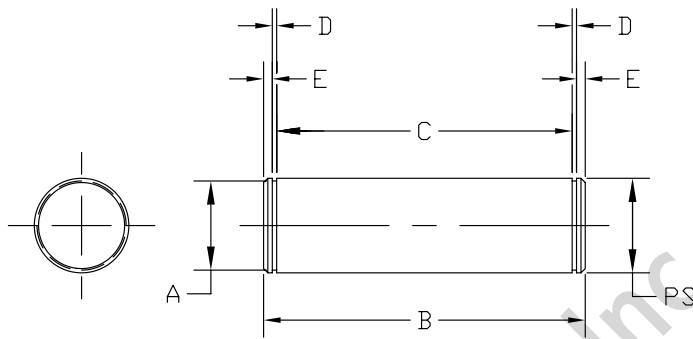

PART NUMBER	PIN SIZE	A	B	C	D	E
12-YP-9003-3-G-A	.500	.470	2.109	1.875	.039	.078
12-YP-9004-3-G-A	.750	.750	2.901	2.625	.046	.092
12-YP-9006-3-G-A	1.000	.943	3.401	3.125	.046	.092
12-YP-9008-3-G-A	1.375	1.295	4.461	4.125	.056	.122
12-YP-9010-3-G-A	1.750	1.655	5.545	5.125	.070	.140
12-YP-9012-3-G-A	2.000	1.891	5.545	5.125	.070	.140
12-YP-9014-3-G-A	2.500	2.266	6.625	6.190	.103	.172
12-YP-9016-3-G-A	3.000	2.844	6.780	6.250	.103	.206
12-YP-9020-3-G-A	3.500	3.322	8.845	8.250	.120	.240
12-YP-9024-3-G-A	4.000	3.782	9.845	9.125	.120	.240

EYE BRACKET

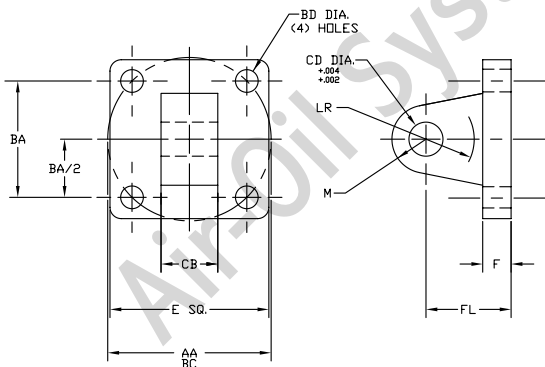

PART NUMBER	AA	BA	BD	CB	CD	E	F	FL	LR	M	M
15-YEB-8903	2.3	1 5/8	13/32	3/4	1/2	2 1/2	3/8	1 1/8	1/2	1/2	1 1/16
15-YEB-8904	3.6	2 9/16	17/32	1 1/4	3/4	3 1/2	5/8	1 7/8	1	3/4	1 3/16
15-YEB-8906	4.6	3 1/4	21/32	1 1/2	1	4 1/2	3/4	2 1/4	1	1	1 3/8
15-YEB-8908	5.4	3 13/16	21/32	2	1 3/8	5	7/8	3	1 1/8	1 3/8	2
15-YEB-8910	7.0	4 15/16	29/32	2 1/2	1 3/4	6 1/2	7/8	3 1/8	1 3/4	1 3/4	2 1/8
15-YEB-8912	8.1	5 3/4	1 1/32	2 1/2	2	7 1/2	1	3 1/2	2	2	2 3/8
15-YEB-8914	9.3	6 19/32	15/32	3	2 1/2	8 1/2	1	4	2 1/2	2 1/2	
15-YEB-8916	10.6	7 1/2	1 9/32	3	3	9 1/2	1	4 1/4	2 3/4	2 3/4	
15-YEB-8920	13.6	9 5/8	1 25/32	4	3 1/2	12 5/8	1 11/16	5 11/16	3 1/2	3 1/2	
15-YEB-8924	16.2	11 1/2	2 1/32	4 1/2	4	14 7/8	1 15/16	6 7/16	3 7/8	4	

SWIVEL EYE BRACKET

PART NUMBER	AA	BA	BD	CB	CD	E	F	FL	LR	M
15-YSB-219-3-1	2.3	1 5/8	13/32	3/4	1/2	2 1/2	3/8	1 1/8	1/2	1 1/16
15-YSB-219-3-2	3.6	2 9/16	17/32	1 1/4	3/4	3 1/2	5/8	1 7/8	1	1 3/16
15-YSB-219-3-3	4.6	3 1/4	21/32	1 1/2	1	4 1/2	3/4	2 1/4	1	1 3/8
15-YSB-219-3-4	5.4	3 13/16	21/32	2	1 3/8	5	7/8	3	1 1/8	2
15-YSB-219-3-5	7.0	4 15/16	29/32	2 1/2	1 3/4	6 1/2	7/8	3 1/8	1 3/4	2 1/8
15-YSB-219-3-6	8.1	5 3/4	1 1/32	2 1/2	2	7 1/2	1	3 1/2	2	2 3/8

(Includes spacers to allow swivel action up to 7° and to make dimensions interchangeable with standard eye bracket.)
NOTE: To assure precision fit-up, pivot pins, machined to special tolerances are furnished with all swivel eye brackets, unless otherwise specified.



ROD END COUPLER AND WELD PLATE

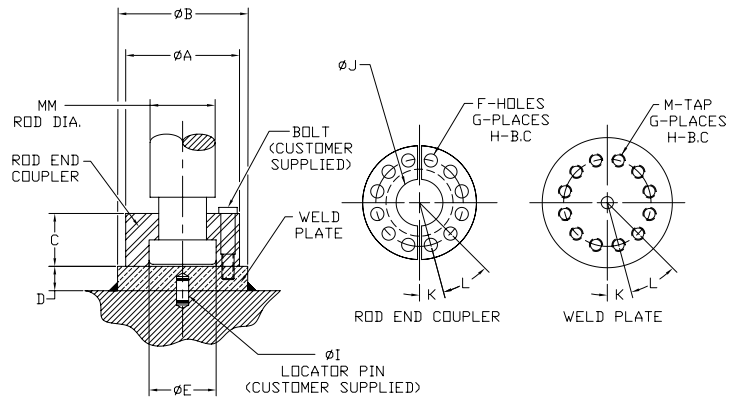

ROD END COUPLER PART#	WELD PLATE PART#	WELD PLATE MATERIAL	MM	A	B	C	D	E	F	G	H	I	J	K	L	M
18-FEC-062	18-FEC-062-WP	CD 1018	5/8	1.500	2.000	.562	.500	.656	.218	4	1.125	250	.406	45°	90°	10-24
18-FEC-100	18-FEC-100-WP	CD 1018	1	2.000	2.500	.875	.500	1.063	.281	6	1.500	250	.750	30°	60°	1/4-20
18-FEC-137	18-FEC-137-WP	CD 1018	1 3/8	2.500	3.000	1.000	.625	1.438	.343	6	2.000	250	.938	30°	60°	5/16-18
18-FEC-175	18-FEC-175-WP	CD 1018	1 3/4	3.000	4.000	1.250	.625	1.813	.343	8	2.375	250	1.187	22.5°	45°	5/16-18
18-FEC-200	18-FEC-200-WP	CD 1018	2	3.500	4.000	1.625	.750	2.063	.406	12	2.688	.375	1.438	15°	30°	3/8-16
18-FEC-250	18-FEC-250-WP	CD 1018	2 1/2	4.000	4.500	1.875	.750	2.625	.406	12	3.188	.375	1.875	15°	30°	3/8-16
18-FEC-300	18-FEC-300-WP	CD 1018	3	5.000	5.500	2.375	1.000	3.125	.531	12	4.000	.375	2.375	15°	30°	1/2-13
18-FEC-350	18-FEC-350-WP	A 36 HRS	3 1/2	5.875	7.000	2.625	1.000	3.625	.656	12	4.688	.375	2.625	15°	30°	5/8-11
18-FEC-400	18-FEC-400-WP	A 36 HRS	4	6.375	7.000	2.625	1.000	4.125	.656	12	5.188	.375	3.125	15°	30°	5/8-11
18-FEC-450	18-FEC-450-WP	A 36 HRS	4 1/2	6.875	8.000	3.125	1.000	4.625	.656	12	5.688	.375	4.625	15°	30°	5/8-11
18-FEC-500	18-FEC-500-WP	A 36 HRS	5	7.375	8.000	3.125	1.000	5.125	.656	12	6.188	.375	4.000	15°	30°	5/8-11
18-FEC-550	18-FEC-550-WP	A 36 HRS	5 1/2	8.250	9.000	3.875	1.250	5.625	.781	12	6.875	.375	4.500	15°	30°	3/4-10
18-FEC-700	18-FEC-700-WP	A 36 HRS	7	10.375	11.000	4.000	1.750	7.125	1.031	12	8.750	.375	5.938	15°	30°	1"-8

MALE SPHERICAL ROD EYE

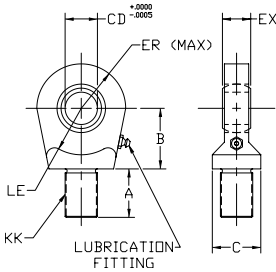

PART NUMBER	CD	KK	A	B	C	ER	EX	LE	MAX LOAD
13-MSRE-0500	.5000	7/16-20	11/16	7/8	7/8	7/8	7/16	3/4	2,600
13-MSRE-0750	.7500	3/4-16	1	1 1/4	1 5/16	1 1/4	21/32	1 1/16	7,080
13-MSRE-1000	1.000	1-14	1 1/2	1 7/8	1 1/2	1 3/8	7/8	1 7/16	12,590
13-MSRE-1375	1.3750	1 1/4-12	2	2 1/8	2	1 13/16	1 3/16	1 7/8	22,930
13-MSRE-1750	1.7500	1 1/2-12	2 1/8	2 1/2	2 1/4	2 3/16	1 17/32	2 1/8	38,220
13-MSRE-2000	2.000	1 7/8-12	2 7/8	2 3/4	2 5/8	2 5/8	1 3/4	2 1/2	50,360

SPHERICAL CLEVIS EYE BRACKET

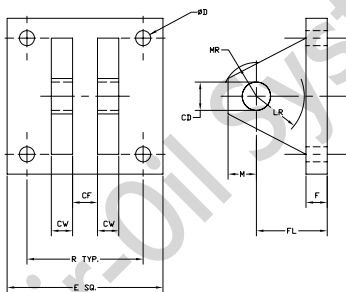

PART NUMBER	CD	CF	CW	D	E	F	FL	M	MR	LR	R
14-YCB-133-03-CBS	.500	.44	.50	.41	.300	.50	.150	.50	.62	.94	.205
14-YCB-133-05-CBS	.750	.66	.62	.53	.375	.62	.200	.88	1.00	1.38	.276
14-YCB-133-06-CBS	1.000	.88	.75	.53	.550	.75	.250	1.00	1.19	1.69	.410
14-YCB-133-08-CBS	1.375	1.19	1.00	.66	.650	.88	.350	1.38	1.62	2.44	.495
14-YCB-133-10-CBS	1.750	1.53	1.25	.91	.850	1.25	.450	1.75	2.06	2.88	.658
14-YCB-133-12-CBS	2.000	1.75	1.50	.91	1.062	1.50	.500	2.00	2.38	3.31	.792

SPHERICAL PINS

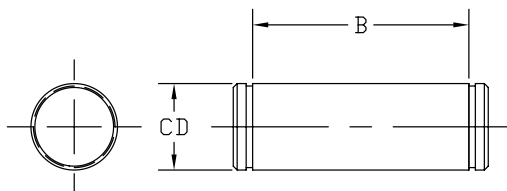

PART NUMBER	CD		B
12-YP-9003-3-G-CBS	.4997	+0.000 -.0004	1 9/16
12-YP-9004-3-G-CBS	.7497	+0.000 -.0005	2 1/32
12-YP-9006-3-CBS	.9997	+0.000 -.0005	2 1/2
12-YP-9008-3-CBS	1.3746	+0.000 -.0006	3 5/16
12-YP-9010-3-CBS	1.7496	+0.000 -.0006	4 7/32
12-YP-9012-3-CBS	1.9996	+0.000 -.0007	4 15/16

STANDARD ROD END STYLES

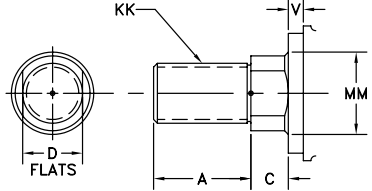
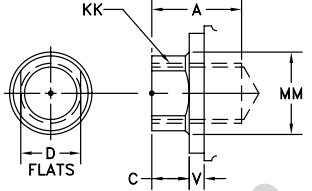
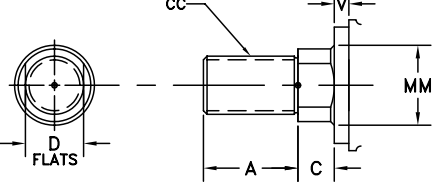
ROD END STYLE #	DIMENSIONS	ROD END STYLE #	DIMENSIONS																																																																																																																	
#2** STANDARD MALE (NFPA-SM)		#4 STANDARD FEMALE (NFPA-SF)																																																																																																																		
#1 STANDARD MALE (NFPA-IM)		<table border="1"> <thead> <tr> <th colspan="6">ADDITIONAL DIMENSIONS</th> </tr> <tr> <th rowspan="2">ROD</th> <th colspan="4">STYLE 9</th> <th rowspan="2">STYLE 8</th> </tr> <tr> <th>AC +/-0.030</th> <th>AD +/-0.010</th> <th>AE+0.000/-0.010</th> <th>AF +/-0.010</th> <th>FT</th> </tr> </thead> <tbody> <tr><td>5/8</td><td>1 1/8</td><td>5/8</td><td>1/4</td><td>3/8</td><td>5/8-18</td></tr> <tr><td>1</td><td>1 1/2</td><td>15/16</td><td>3/8</td><td>11/16</td><td>1-14</td></tr> <tr><td>1 3/8</td><td>1 3/4</td><td>1 1/16</td><td>3/8</td><td>7/8</td><td>1 3/8-12</td></tr> <tr><td>1 3/4</td><td>2</td><td>1 5/16</td><td>1/2</td><td>1 1/8</td><td>1 3/4-12</td></tr> <tr><td>2</td><td>2 5/8</td><td>1 11/16</td><td>5/8</td><td>1 3/8</td><td>2-12</td></tr> <tr><td>2 1/2</td><td>3 1/4</td><td>1 15/16</td><td>3/4</td><td>1 3/4</td><td>2 1/2-12</td></tr> <tr><td>3</td><td>3 5/8</td><td>2 7/16</td><td>7/8</td><td>2 1/4</td><td>3-12</td></tr> <tr><td>3 1/2</td><td>4 3/8</td><td>2 11/16</td><td>1</td><td>2 1/2</td><td>3 1/2-12</td></tr> <tr><td>4</td><td>4 1/2</td><td>2 11/16</td><td>1</td><td>3</td><td>4-12</td></tr> <tr><td>4 1/2</td><td>5 1/4</td><td>3 3/16</td><td>1 1/2</td><td>3 1/2</td><td>4 1/2-12</td></tr> <tr><td>5</td><td>5 3/8</td><td>3 3/16</td><td>1 1/2</td><td>3 7/8</td><td>5-12</td></tr> <tr><td>5 1/2</td><td>6 1/4</td><td>3 15/16</td><td>1 7/8</td><td>4 3/8</td><td>5 1/2-12</td></tr> <tr><td>7</td><td>6 1/2</td><td>4 1/16</td><td>2</td><td>5 3/4</td><td>7-12</td></tr> <tr><td>8</td><td>6 1/2</td><td>4 1/16</td><td>2</td><td>6 1/2</td><td>8-12</td></tr> <tr><td>9</td><td>6 3/4</td><td>4 1/8</td><td>2 3/8</td><td>7 1/4</td><td>9-12</td></tr> <tr><td>10</td><td>7 1/4</td><td>4 5/8</td><td>2 3/8</td><td>8</td><td>10-12</td></tr> </tbody> </table>		ADDITIONAL DIMENSIONS						ROD	STYLE 9				STYLE 8	AC +/-0.030	AD +/-0.010	AE+0.000/-0.010	AF +/-0.010	FT	5/8	1 1/8	5/8	1/4	3/8	5/8-18	1	1 1/2	15/16	3/8	11/16	1-14	1 3/8	1 3/4	1 1/16	3/8	7/8	1 3/8-12	1 3/4	2	1 5/16	1/2	1 1/8	1 3/4-12	2	2 5/8	1 11/16	5/8	1 3/8	2-12	2 1/2	3 1/4	1 15/16	3/4	1 3/4	2 1/2-12	3	3 5/8	2 7/16	7/8	2 1/4	3-12	3 1/2	4 3/8	2 11/16	1	2 1/2	3 1/2-12	4	4 1/2	2 11/16	1	3	4-12	4 1/2	5 1/4	3 3/16	1 1/2	3 1/2	4 1/2-12	5	5 3/8	3 3/16	1 1/2	3 7/8	5-12	5 1/2	6 1/4	3 15/16	1 7/8	4 3/8	5 1/2-12	7	6 1/2	4 1/16	2	5 3/4	7-12	8	6 1/2	4 1/16	2	6 1/2	8-12	9	6 3/4	4 1/8	2 3/8	7 1/4	9-12	10	7 1/4	4 5/8	2 3/8	8	10-12
ADDITIONAL DIMENSIONS																																																																																																																				
ROD	STYLE 9				STYLE 8																																																																																																															
	AC +/-0.030	AD +/-0.010	AE+0.000/-0.010	AF +/-0.010		FT																																																																																																														
5/8	1 1/8	5/8	1/4	3/8	5/8-18																																																																																																															
1	1 1/2	15/16	3/8	11/16	1-14																																																																																																															
1 3/8	1 3/4	1 1/16	3/8	7/8	1 3/8-12																																																																																																															
1 3/4	2	1 5/16	1/2	1 1/8	1 3/4-12																																																																																																															
2	2 5/8	1 11/16	5/8	1 3/8	2-12																																																																																																															
2 1/2	3 1/4	1 15/16	3/4	1 3/4	2 1/2-12																																																																																																															
3	3 5/8	2 7/16	7/8	2 1/4	3-12																																																																																																															
3 1/2	4 3/8	2 11/16	1	2 1/2	3 1/2-12																																																																																																															
4	4 1/2	2 11/16	1	3	4-12																																																																																																															
4 1/2	5 1/4	3 3/16	1 1/2	3 1/2	4 1/2-12																																																																																																															
5	5 3/8	3 3/16	1 1/2	3 7/8	5-12																																																																																																															
5 1/2	6 1/4	3 15/16	1 7/8	4 3/8	5 1/2-12																																																																																																															
7	6 1/2	4 1/16	2	5 3/4	7-12																																																																																																															
8	6 1/2	4 1/16	2	6 1/2	8-12																																																																																																															
9	6 3/4	4 1/8	2 3/8	7 1/4	9-12																																																																																																															
10	7 1/4	4 5/8	2 3/8	8	10-12																																																																																																															

OPTIONAL ROD END STYLES

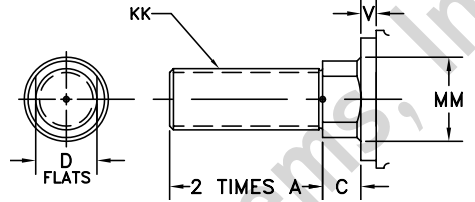
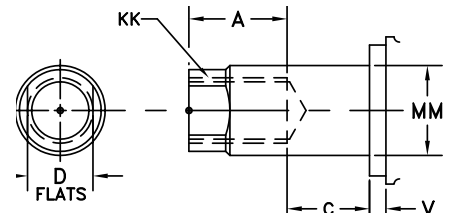
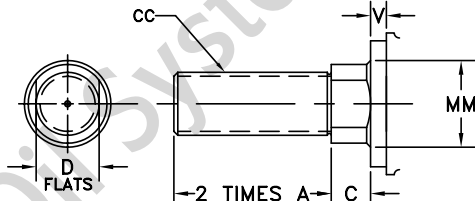
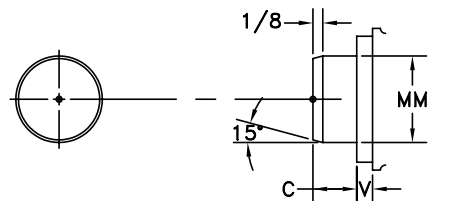
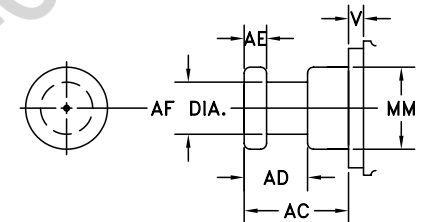
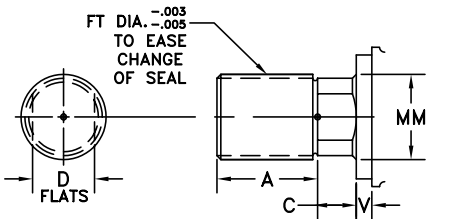
ROD END STYLE #	DIMENSIONS	ROD END STYLE #	DIMENSIONS
#5		#3 (NFPA-LF)	
#6		#7 (NFPA-PL)	
#9		#8 (NFPA-FM)	

**** MALE ROD END STYLE #2 WILL BE FURNISHED UNLESS OTHERWISE SPECIFIED**

(4) SPANNER HOLES USED INSTEAD OF FLATS ON 4" DIA. AND LARGER.

NOTE: CONSULT FACTORY FOR ROD END CONFIGURATIONS OTHER THAN THOSE SHOWN.

NOTE: ALL YATES MOUNTING ACCESSORIES ARE DESIGNED TO FIT #2 ROD END STYLES



HEAVY DUTY PNEUMATIC
Series A4

MEDIUM DUTY HYDRAULIC
Series H4

PERMANENTLY LUBRICATED HEAVY DUTY PNEUMATIC
Series L4



A4/L4/H4 FEATURES

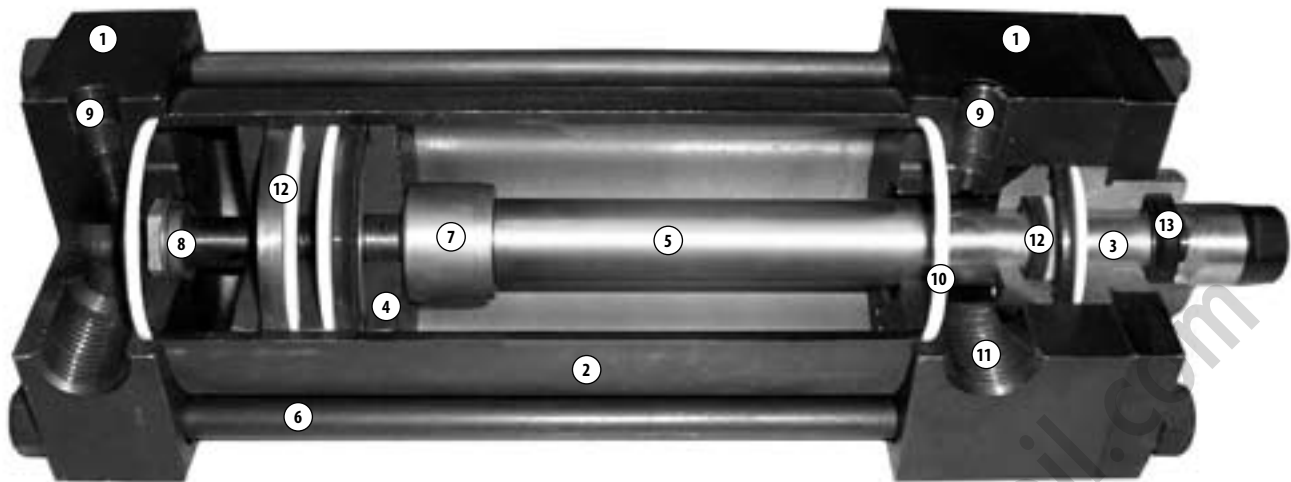

- 1. HEAD/CAP-** Precision machined steel head and cap provide close concentricity and accurate alignment between piston, tube, piston rod and rod bearing.
- 2. CYLINDER BARREL-** Damage resistant tubing honed to an 8 to 16 micro finish for low frictional drag and maximum seal life. Hard chrome plated to resist corrosion and scoring.
- 3. ROD CARTRIDGE-** Extra long, high strength bronze gland provides maximum bearing support and wear resistance. With certain exceptions a removable retainer allows for gland removal without cylinder disassembly.
- 4. PISTON-** One piece fine grained cast iron piston provides maximum strength and protection against shock loads. Anaerobic adhesive is used to permanently lock and seal the piston to the rod.
- 5. PISTON ROD-** High strength damage resistant piston rod provides 100,000 PSI minimum yield material in 5/8" through 4 1/2" diameters. Larger diameters vary between 50,000 and 75,000 PSI minimum yield material. All rods are case hardened to 50-55 RC and hard chrome plated to provide maximum wear life. Stainless steel is also available.
- 6. TIE RODS-** 100,000 to 125,000 PSI minimum yield steel, pre-stressed for fatigue resistance, and roll threaded for added strength.
- 7. HEAD CUSHIONS-** Self centering head cushion design provides consistent cushioning performance.
- 8. CAP CUSHIONS-** Floating cap cushion insert design replaces ball check to provide greater flow area for fast break away and provides consistent cushioning performance.
- 9. CUSHION NEEDLE ADJUSTMENT AND BALL CHECK-** Flush mounted captive cushion adjustment allows safe cushion adjustment under pressure. Special tip design and fine threads allow precise adjustment over a broad range of operations. Cushion ball check provided at head end allows for fast break away under full power.
- 10. TUBE SEALS-** Extrusion resistant Teflon® material is compatible with virtually all fluids and can operate in temperatures to 500°F.
- 11. PORTS-** NPT ports are standard and can be rotated to any 90 degree position in relation to each other and the mounting. SAE ports optional.
- 12. RODS AND PISTON SEALS-** Pressure energized nitrile U-cups, with Teflon® back-up rings are standard. Step cut cast iron rings and Viton® seals for temperatures to 400°F are optional. Special seals for low friction, high speed applications are also available.
- 13. ROD WIPER-** Nitrile double lip rod wiper acts as secondary seal while keeping dirt, dust and other contaminants out. Optional Viton® wiper available for fluid compatibility or temperatures to 400°F. Metallic scrapers and low friction wipers also available.

SIDE MOUNTS

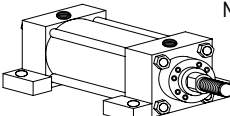
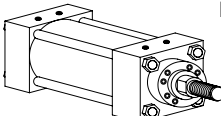
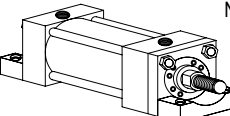
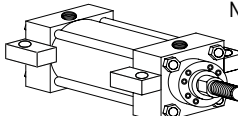
<p>STYLE A PAGE 44-47 NFA-MS2</p>  <p>SIDE LUGS 1 1/2-20" BORE</p>	<p>STYLE B PAGE 44-47 NFA-MS4</p>  <p>SIDE TAPPED 1 1/2-20" BORE</p>	<p>STYLE E PAGE 48-49 NFA-MS7</p>  <p>SIDE END LUGS 1 1/2-14" BORE</p>	<p>STYLE H PAGE 44-47 NFA-MS3</p>  <p>CENTER-LINE LUGS 1 1/2-20" BORE</p>
---	---	--	--

END MOUNTS

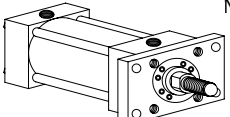
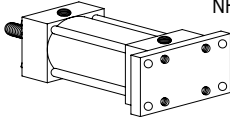
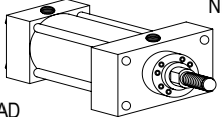
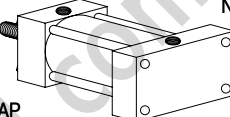
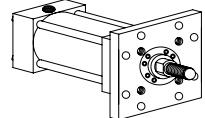
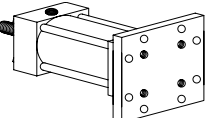
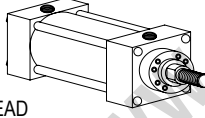
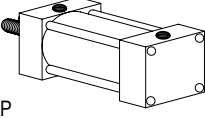
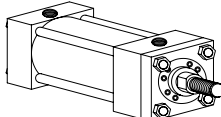
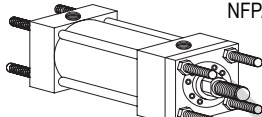
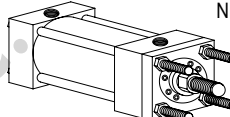
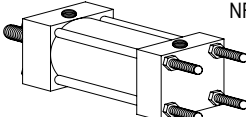
<p>STYLE F PAGE 62 NFA-MF1</p>  <p>HEAD RECTANGULAR FLANGE 1 1/2-6" BORE</p>	<p>STYLE R PAGE 62 NFA-MF2</p>  <p>CAP RECTANGULAR FLANGE 1 1/2-6" BORE</p>	<p>STYLE G PAGE 64 NFA-ME5</p>  <p>HEAD RECTANGULAR INTEGRAL FLANGE 1 1/2-6" BORE</p>	<p>STYLE P PAGE 64 NFA-ME6</p>  <p>CAP RECTANGULAR INTEGRAL FLANGE 1 1/2-6" BORE</p>
<p>STYLE J PAGE 62 NFA-MF5</p>  <p>HEAD SQUARE FLANGE 1 1/2-6" BORE</p>	<p>STYLE S PAGE 62 NFA-MF6</p>  <p>CAP SQUARE FLANGE 1 1/2-6" BORE</p>	<p>STYLE X PAGE 66 NFA-ME3</p>  <p>HEAD SQUARE INTEGRAL FLANGE 8-20" BORE</p>	<p>STYLE Z PAGE 66 NFA-ME4</p>  <p>CAP SQUARE INTEGRAL FLANGE 8-20" BORE</p>
<p>STYLE K PAGE 68-71 NFA-MX0</p>  <p>NO TIE RODS EXTENDED 1 1/2-20" BORE</p>	<p>STYLE L PAGE 68-71 NFA-MX1</p>  <p>BOTH ENDS TIE RODS EXTENDED 1 1/2-20" BORE</p>	<p>STYLE M PAGE 68-71 NFA-MX3</p>  <p>HEAD TIE RODS EXTENDED 1 1/2-20" BORE</p>	<p>STYLE N PAGE 68-71 NFA-MX2</p>  <p>CAP TIE RODS EXTENDED 1 1/2-20" BORE</p>

PIVOT MOUNTS – CLEVIS AND EYE

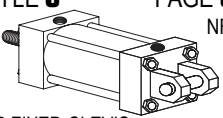
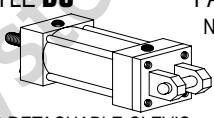
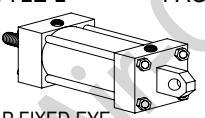
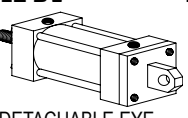
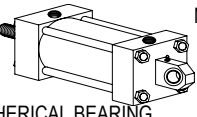
<p>STYLE C PAGE 52-55 NFA-MP1</p>  <p>CAP FIXED CLEVIS 1 1/2-20" BORE</p>	<p>STYLE DC PAGE 56 NFA-MP2</p>  <p>CAP DETACHABLE CLEVIS 1 1/2-6" BORE</p>
<p>STYLE V PAGE 52-55 NFA-MP3</p>  <p>CAP FIXED EYE 1 1/2-20" BORE</p>	<p>STYLE DV PAGE 56 NFA-MP4</p>  <p>CAP DETACHABLE EYE 1 1/2-6" BORE</p>
<p>STYLE Q PAGE 50-51 NFA-MPU3</p>  <p>SPHERICAL BEARING 1 1/2-14" BORE</p>	

PIVOT MOUNTS – TRUNNION

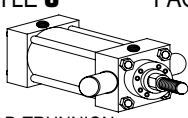
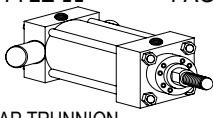
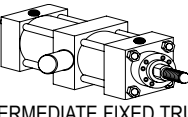
<p>STYLE U PAGE 58-61 NFA-MT1</p>  <p>HEAD TRUNNION 1 1/2-20" BORE</p>
<p>STYLE W PAGE 58-61 NFA-MT2</p>  <p>CAP TRUNNION 1 1/2-20" BORE</p>
<p>STYLE T PAGE 58-61 NFA-MT4</p>  <p>INTERMEDIATE FIXED TRUNNION 1 1/2-14" BORE</p>

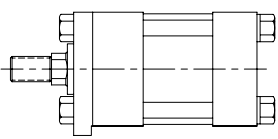
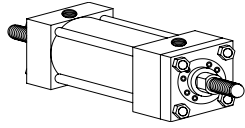
<p>EXTENDED KEY PLATE (ADD "S" IN PART # AND STATE EXTENDED KEY PLATE IN DESCRIPTION)</p>  <p>1 1/2-6" BORE PAGE 73</p>
<p>DOUBLE ROD END (ADD "D" AFTER STYLE)</p>  <p>1 1/2-20" BORE PAGE 72</p>



PRESSURE RATINGS

CYLINDER BORE (INCHES)	PISTON ROD DIAMETER (INCHES)			PRESSURE RATINGS (PSI)	
	STANDARD	OVERSIZE	2:1	HEAVY-DUTY SERVICE	4:1 SAFETY FACTOR
1 1/2	5/8		1	1500 *	1800
2	5/8	1	1 3/8	1400 *	950
2 1/2	5/8	1, 1 3/8	1 3/4	1100 *	600
3 1/4	1	1 3/8, 1 3/4	2	1300 *	900
4	1	1 3/8, 1 3/4, 2	2 1/2	900 *	650
5	1	1 3/8, 1 3/4, 2, 2 1/2, 3	3 1/2	750 *	650
6	1 3/8	1 3/4, 2, 2 1/2, 3, 3 1/2	4	700 *	450
8	1 3/8	1 3/4, 2, 2 1/2, 3, 3 1/2, 4, 4 1/2, 5		500 *	550
10	1 3/4	2, 2 1/2, 3, 3 1/2, 4, 4 1/2, 5, 5 1/2		400 *	350
12	2	2 1/2, 3, 3 1/2, 4, 4 1/2, 5, 5 1/2		400 *	
14	2 1/2	3, 3 1/2, 4, 4 1/2, 5, 5 1/2		400 *	
16	3 1/2	4, 4 1/2, 5, 5 1/2		450 *	
18	4	4 1/2, 5, 5 1/2		400 *	
20	4	4 1/2, 5, 5 1/2		400 *	

FOR HIGHER PRESSURES CONSULT FACTORY

* PRESSURE FOR "F" AND "R" MOUNTS IS LOWER SEE PAGE 63

Φ 4:1 SAFETY FACTOR BASED ON FAILURE PRESSURES OF WEAKEST COMPONENT AND STANDARD ROD SIZE

RETAINER INFORMATION

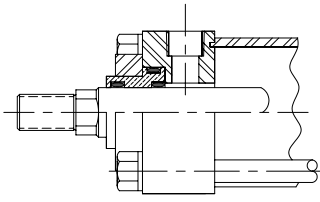
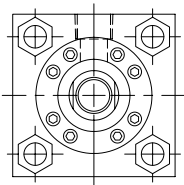

A4 and H4 cylinders with the following bore and rod combinations use circular retainers which permit removal of rod cartridge without disassembling cylinder.

- 2 1/2" bore with 5/8" and 1" rods
- 3 1/4" bore with 1" and 1 3/8" rods
- 4" bore with 1", 1 3/8", 1 3/4", and 2" rods
- 5" bore with 1", 1 3/8", 1 3/4", 2", and 2 1/2" rods
- 6" bore with 1 3/8", 1 3/4", 2", 2 1/2", 3", and 3 1/2" rods
- 8" thru 20" bores with all rod diameters

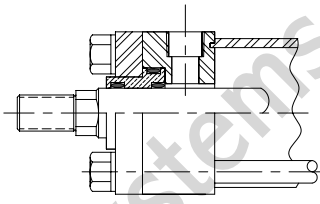
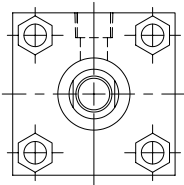

A4 and H4 cylinders with the following bore and rod combinations use full plate retainer construction.

- 1 1/2" bore with 5/8" and 1" rods
- 2" bore with 5/8", 1", and 1 3/8" rods
- 2 1/2" bore with 1 3/8" and 1 3/4" rods
- 3 1/4" bore with 1 3/4" and 2" rods
- 4" bore with 2 1/2" rod
- 5" bore with 3" and 3 1/2" rods
- 6" bore with 4" rod

TIE ROD INFORMATION

On large bore cylinders, two tie rods are used at each corner of the 16, 18 and 20 inch bore sizes. This reduces flexing of head and cap under pressure.

BORE	RA	RB	TIE ROD THREAD
16	7.745	5.234	1-14
18	8.396	5.879	1 1/8-12
20	9.266	6.488	1 1/4-12

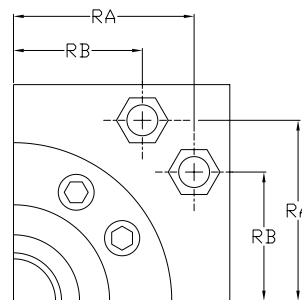

SIDE LUGS MOUNT

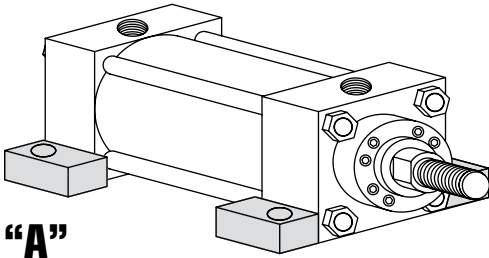

"A"
YATES STYLE A
NFPA-MS2

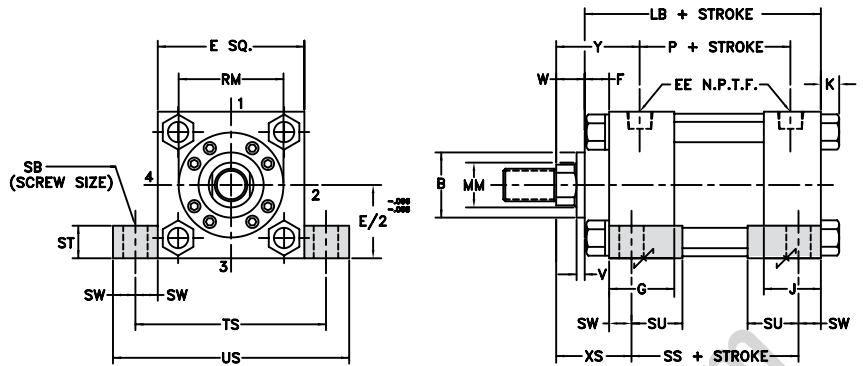

SIDE TAPPED MOUNT

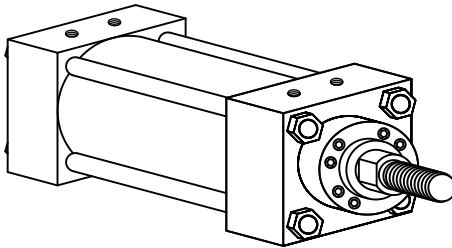

"B"
YATES STYLE B
NFPA-MS4

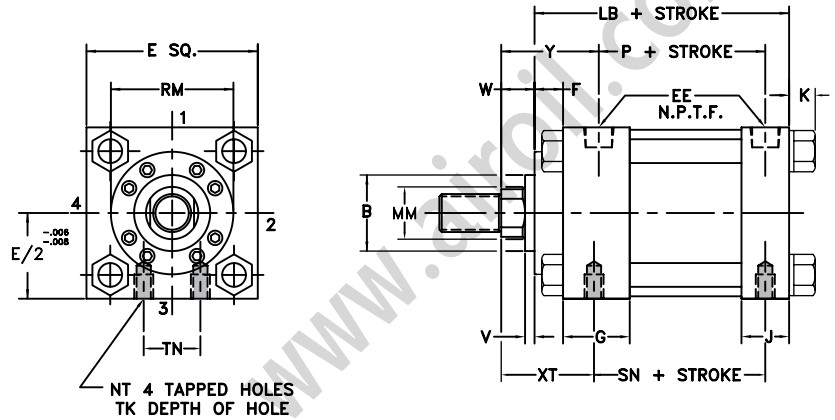

CENTER-LINE LUGS MOUNT

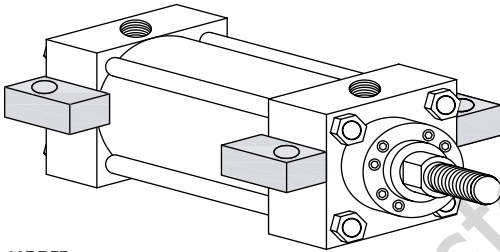

"H"
YATES STYLE H
NFPA-MS3

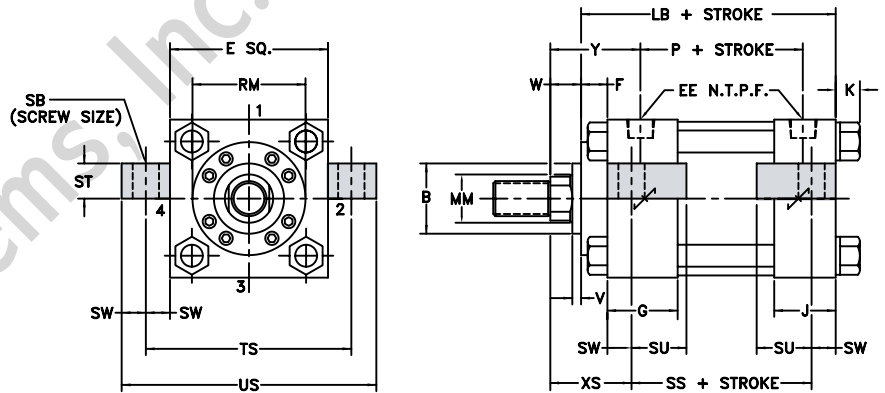

STANDARD ROD ENDS

#2 STD MALE
NFPA-SM

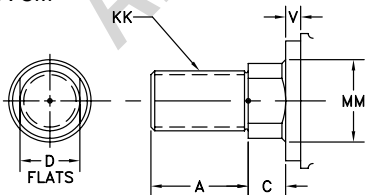

#4 STD FEMALE
NFPA-SF

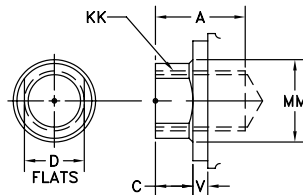

#1 MALE
NFPA-IM

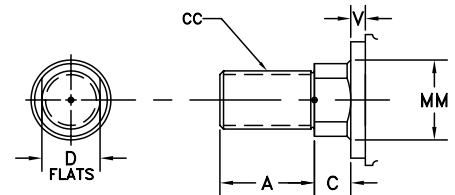

BORE	SAE															ADD STROKE			
	E	EE	OPT	F	G	J	K	SB	ST	SU	SW	TS	US	NT	TN	LB	P	SS *	SN
1 1/2	2	3/8	6	3/8	1 1/2	1	1/4	3/8	1/2	15/16	3/8	2 3/4	3 1/2	1/4-20	5/8	4	2 3/16	2 7/8	2 1/4
2	2 1/2	3/8	6	3/8	1 1/2	1	5/16	3/8	1/2	15/16	3/8	3 1/4	4	5/16-18	7/8	4	2 3/16	2 7/8	2 1/4
2 1/2	3	3/8	6	3/8	1 1/2	1	5/16	3/8	1/2	15/16	3/8	3 3/4	4 1/2	3/8-16	1 1/4	4 1/8	2 5/16	3	2 3/8
3 1/4	3 3/4	1/2	10	5/8	1 3/4	1 1/4	3/8	1/2	3/4	1 1/4	1/2	4 3/4	5 3/4	1/2-13	1 1/2	4 7/8	2 5/8	3 1/4	2 5/8
4	4 1/2	1/2	10	5/8	1 3/4	1 1/4	3/8	1/2	3/4	1 1/4	1/2	5 1/2	6 1/2	1/2-13	2 1/16	4 7/8	2 5/8	3 1/4	2 5/8
5	5 1/2	1/2	10	5/8	1 3/4	1 1/4	7/16	3/4	1	1 9/16	11/16	6 7/8	8 1/4	5/8-11	2 11/16	5 1/8	2 7/8	3 1/8	2 7/8
6	6 1/2	3/4	12	3/4	2	1 1/2	7/16	3/4	1	1 9/16	11/16	7 7/8	9 1/4	3/4-10	3 1/4	5 3/4	3 1/8	3 5/8	3 1/8
8	8 1/2	3/4	12	3/4	2	1 1/2	9/16	3/4	1	1 9/16	11/16	9 7/8	11 1/4	3/4-10	4 1/2	5 7/8	3 1/4	3 3/4	3 1/4

BORE	ROD DIA. MM	THREAD		ROD EXTENSIONS AND PILOT DIMENSIONS									ENVELOPE AND MOUNTING DIMENSIONS		
		KK	CC	A	B ‡	C	D	V	W	TK	RM	XS	XT	Y	
1 1/2	5/8	7/16-20	1/2-20	3/4	1 1/8	3/8	1/2	1/4	5/8	3/8	§	1 3/8	1 15/16	1 31/32	
	1 †	3/4-16	7/8-14	1 1/8	1 1/2	1/2	7/8	1/2	1	⊕	§	1 3/4	2 5/16	2 11/32	
2	5/8	7/16-20	1/2-20	3/4	1 1/8	3/8	1/2	1/4	5/8	1/2	§	1 3/8	1 15/16	1 31/32	
	1	3/4-16	7/8-14	1 1/8	1 1/2	1/2	7/8	1/2	1	1/2	§	1 3/4	2 5/16	2 11/32	
	1 3/8 †	1-14	1 1/4-12	1 5/8	2	5/8	1 1/8	5/8	1 1/4	⊕	§	2	2 9/16	2 19/32	
2 1/2	5/8	7/16-20	1/2-20	3/4	1 1/8	3/8	1/2	1/4	5/8	5/8	2 3/8	1 3/8	1 15/16	1 31/32	
	1	3/4-16	7/8-14	1 1/8	1 1/2	1/2	7/8	1/2	1	5/8	2 5/8	1 3/4	2 5/16	2 11/32	
	1 3/8	1-14	1 1/4-12	1 5/8	2	5/8	1 1/8	5/8	1 1/4	5/8	§	2	2 9/16	2 19/32	
	1 3/4 †	1 1/4-12	1 1/2-12	2	2 3/8	3/4	1 1/2	3/4	1 1/2	⊕	§	2 1/4	2 13/16	2 27/32	
3 1/4	1	3/4-16	7/8-14	1 1/8	1 1/2	1/2	7/8	1/4	3/4	3/4	2 5/8	1 7/8	2 7/16	2 71/16	
	1 3/8	1-14	1 1/4-12	1 5/8	2	5/8	1 1/8	3/8	1	3/4	3 7/32	2 1/8	2 11/16	2 11/16	
	1 3/4	1 1/4-12	1 1/2-12	2	2 3/8	3/4	1 1/2	1/2	1 1/4	⊕	§	2 3/8	2 15/16	2 15/16	
	2 †	1 1/2-12	1 3/4-12	2 1/4	2 5/8	7/8	1 3/4	1/2	1 3/8	⊕	§	2 1/2	3 1/16	3 1/16	
	4	3/4-16	7/8-14	1 1/8	1 1/2	1/2	7/8	1/4	3/4	3/4	2 5/8	1 7/8	2 7/16	2 7/16	
4	1 3/8	1-14	1 1/4-12	1 5/8	2	5/8	1 1/8	3/8	1	3/4	3 7/32	2 1/8	2 11/16	2 11/16	
	1 3/4	1 1/4-12	1 1/2-12	2	2 3/8	3/4	1 1/2	1/2	1 1/4	3/4	3 7/8	2 3/8	2 15/16	2 15/16	
	2	1 1/2-12	1 3/4-12	2 1/4	2 5/8	7/8	1 3/4	1/2	1 3/8	⊕	4	2 1/2	3 1/16	3 1/16	
	2 1/2 †	1 7/8-12	2 1/4-12	3	3 1/8	1	2 1/8	5/8	1 5/8	⊕	§	2 3/4	3 5/16	3 5/16	
	5	3/4-16	7/8-14	1 1/8	1 1/2	1/2	7/8	1/4	3/4	1	2 5/8	2 1/16	2 7/16	2 7/16	
	1 3/8	1-14	1 1/4-12	1 5/8	2	5/8	1 1/8	3/8	1	1	3 7/32	2 5/16	2 11/16	2 11/16	
5	1 3/4	1 1/4-12	1 1/2-12	2	2 3/8	3/4	1 1/2	1/2	1 1/4	1	3 7/8	2 9/16	2 15/16	2 15/16	
	2	1 1/2-12	1 3/4-12	2 1/4	2 5/8	7/8	1 3/4	1/2	1 3/8	1	4	2 11/16	3 1/16	3 1/16	
	2 1/2	1 7/8-12	2 1/4-12	3	3 1/8	1	2 1/8	5/8	1 5/8	1	4 7/16	2 15/16	3 5/16	3 5/16	
	3	2 1/4-12	2 3/4-12	3 1/2	3 3/4	1	2 5/8	5/8	1 5/8	⊕	§	2 15/16	3 5/16	3 5/16	
	3 1/2 †	2 1/2-12	3 1/4-12	3 1/2	4 1/4	1	3	5/8	1 5/8	⊕	§	2 15/16	3 5/16	3 5/16	
	6	3/4-16	7/8-14	1 1/8	1 1/2	1/2	7/8	1/4	3/4	3/4	2 5/8	1 7/8	2 7/16	2 7/16	
6	1 3/8	1-14	1 1/4-12	1 5/8	2	5/8	1 1/8	1/4	7/8	1 1/8	3 7/32	2 5/16	2 13/16	2 13/16	
	1 3/4	1 1/4-12	1 1/2-12	2	2 3/8	3/4	1 1/2	3/8	1 1/8	1 1/8	3 7/8	2 9/16	3 1/16	3 1/16	
	2	1 1/2-12	1 3/4-12	2 1/4	2 5/8	7/8	1 3/4	3/8	1 1/4	1 1/8	4	2 11/16	3 3/16	3 3/16	
	2 1/2	1 7/8-12	2 1/4-12	3	3 1/8	1	2 1/8	1/2	1 1/2	1 1/8	4 7/16	2 15/16	3 7/16	3 7/16	
	3	2 1/4-12	2 3/4-12	3 1/2	3 3/4	1	2 5/8	1/2	1 1/2	1 1/8	5 1/4	2 15/16	3 7/16	3 7/16	
	3 1/2	2 1/2-12	3 1/4-12	3 1/2	4 1/4	1	3	1/2	1 1/2	1 1/8	5 5/8	2 15/16	3 7/16	3 7/16	
	4	3-12	3 3/4-12	4	4 3/4	1	Δ	1/2	1 1/2	⊕	§	2 15/16	3 7/16	3 7/16	
8	1 3/8	1-14	1 1/4-12	1 5/8	2	5/8	1 1/8	1/4	7/8	1 1/8	3 7/32	2 5/16	2 13/16	2 13/16	
	1 3/4	1 1/4-12	1 1/2-12	2	2 3/8	3/4	1 1/2	3/8	1 1/8	1 1/8	3 7/8	2 9/16	3 1/16	3 1/16	
	2	1 1/2-12	1 3/4-12	2 1/4	2 5/8	7/8	1 3/4	3/8	1 1/4	1 1/8	4	2 11/16	3 3/16	3 3/16	
	2 1/2	1 7/8-12	2 1/4-12	3	3 1/8	1	2 1/8	1/2	1 1/2	1 1/8	4 7/16	2 15/16	3 7/16	3 7/16	
	3	2 1/4-12	2 3/4-12	3 1/2	3 3/4	1	2 5/8	1/2	1 1/2	1 1/8	5 1/4	2 15/16	3 7/16	3 7/16	
	3 1/2	2 1/2-12	3 1/4-12	3 1/2	4 1/4	1	3	1/2	1 1/2	1 1/8	5 5/8	2 15/16	3 7/16	3 7/16	
	4	3-12	3 3/4-12	4	4 3/4	1	Δ	1/2	1 1/2	1 1/8	6 7/16	2 15/16	3 7/16	3 7/16	
8	4 1/2	3 1/4-12	4 1/4-12	4 1/2	5 1/4	1	Δ	1/2	1 1/2	1 1/8	7 1/8	2 15/16	3 7/16	3 7/16	
	5	3 1/2-12	4 3/4-12	5	5 3/4	1	Δ	1/2	1 1/2	1 1/8	7 5/8	2 15/16	3 7/16	3 7/16	

† HEAD END PORTS SHALLOW TAPPED
 Ω FIXED CUSHIONS FURNISHED AT THE HEAD END IN THESE SIZES
 Δ (4) SPANNER HOLES USED INSTEAD OF FLATS ON 4" DIA. AND LARGER RODS
 § THESE CYLINDERS HAVE FULL PLATE RETAINERS. USE "E" DIMENSION INSTEAD OF "RM" - SEE PAGE 42

‡ B DIMENSION TOLERANCE -.001/- .003
 * SS DIMENSION CHANGES ON DOUBLE ROD CYLINDERS - SEE PAGE 72 FOR DETAILS
 NOTE: SUGGESTED THAT THESE MOUNTS BE KEYPED OR PINNED TO PREVENT SHIFTING
 ⊕ CONSULT FACTORY FOR THREAD DEPTH



SIDE LUGS MOUNT

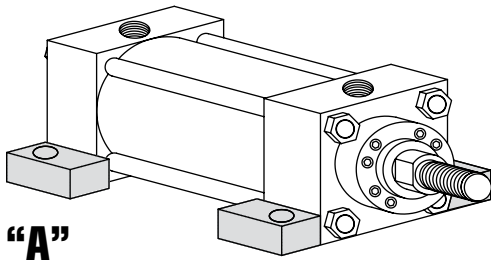

"A"
YATES STYLE A
NFPA-MS2

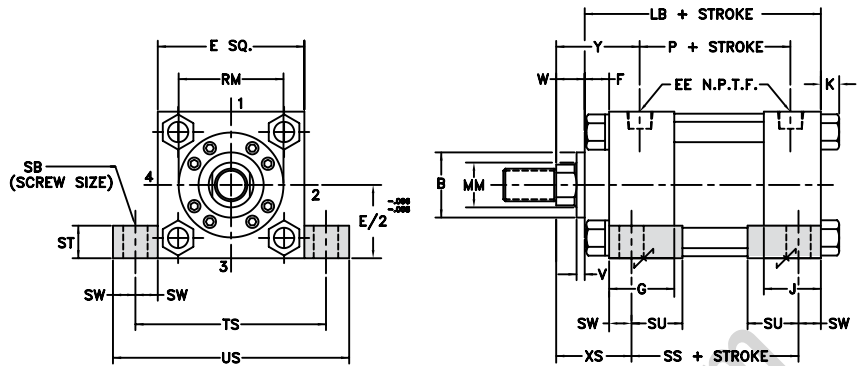

SIDE TAPPED MOUNT

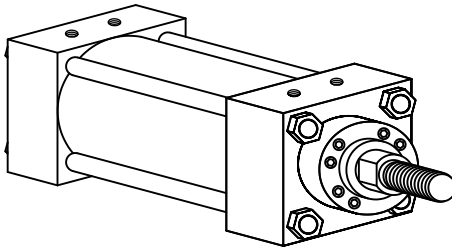

"B"
YATES STYLE B
NFPA-MS4

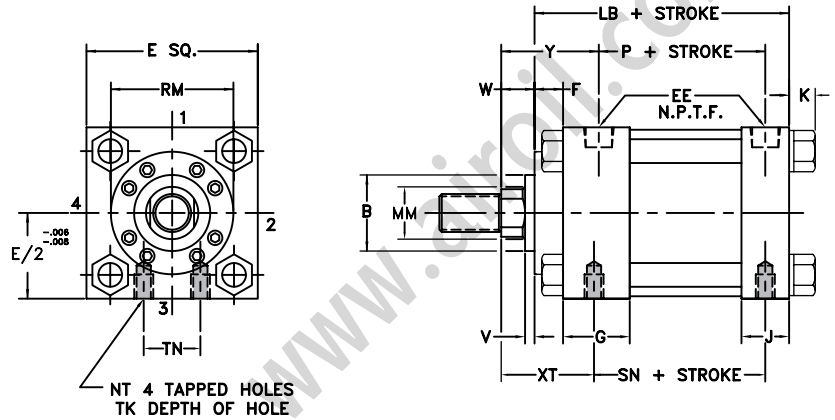

CENTER-LINE LUGS MOUNT

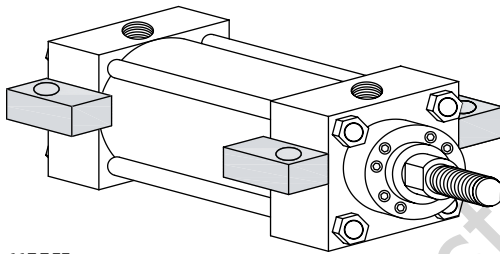

"H"
YATES STYLE H
NFPA-MS3

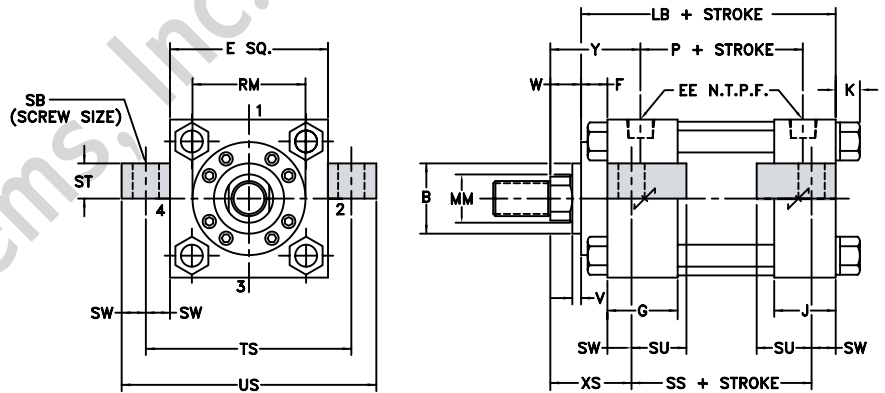

STANDARD ROD ENDS

#2 STD MALE
NFPA-SM

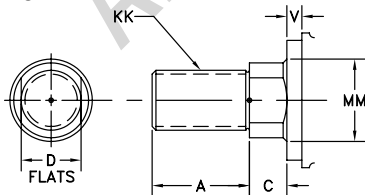

#4 STD FEMALE
NFPA-SF

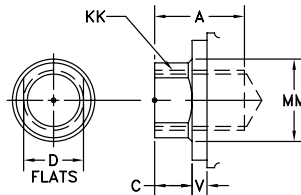

#1 MALE
NFPA-IM

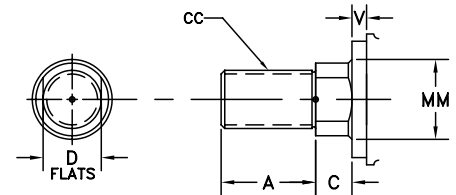

BORE	SAE															ADD STROKE			
	E	EE	OPT	F	G	J	K	SB	ST	SU	SW	TS	US	NT	TN	LB	P	SS *	SN
10	10 5/8	1	16	3/4	2 1/4	2	11/16	1	1 1/4	2	7/8	12 3/8	14 1/8	1-8	5 1/2	7 1/8	4 1/8	4 5/8	4 1/8
12	12 3/4	1	16	3/4	2 1/4	2	11/16	1	1 1/4	2	7/8	14 1/2	16 1/4	1-8	7 1/4	7 5/8	4 5/8	5 1/8	4 5/8
14	14 3/4	1 1/4	20	3/4	2 3/4	2 1/4	13/16	1 1/4	1 1/2	2 1/2	1 1/8	17	19 1/4	1 1/4-7	8 3/8	8 7/8	5 1/2	5 7/8	5 1/2
16	17 1/2	1 1/2	24	3/4	2 15/16	2 15/16	15/16	1 3/4	2	3 1/2	1 3/4	21	24 1/4	1 3/4-12	7	10	6 1/2	5 3/4	6 1/2
18	19 1/2	1 1/2	24	7/8	3 7/16	3 7/16	1	2	2 1/2	3 1/2	2	23 1/2	27 1/2	2-12	8	11 1/8	6 1/2	6 1/4	7
20	21 3/4	2	32	7/8	3 15/16	3 15/16	1 1/8	2 1/4	3	3 5/8	2 3/8	26 1/2	31 1/4	2 1/4-12	8 1/2	12 5/8	7 3/8	7	7 3/4

BORE	ROD DIA.	THREAD		ROD EXTENSIONS AND PILOT DIMENSIONS									ENVELOPE AND MOUNTING DIMENSIONS		
		MM	KK	CC	A	B ±	C	D	V	W	TK	RM	XS	XT	Y
10	1 3/4	1 1/4-12	1 1/2-12	2	2 3/8	3/4	1 1/2	3/8	1 1/8	1 1/2	3 7/8	2 3/4	3 1/8	3 1/8	
	2	1 1/2-12	1 3/4-12	2 1/4	2 5/8	7/8	1 3/4	3/8	1 1/4	1 1/2	4	2 7/8	3 1/4	3 1/4	
	2 1/2	1 7/8-12	2 1/4-12	3	3 1/8	1	2 1/8	1/2	1 1/2	1 1/2	4 7/16	3 1/8	3 1/2	3 1/2	
	3	2 1/4-12	2 3/4-12	3 1/2	3 3/4	1	2 5/8	1/2	1 1/2	1 1/2	5 1/4	3 1/8	3 1/2	3 1/2	
	3 1/2	2 1/2-12	3 1/4-12	3 1/2	4 1/4	1	3	1/2	1 1/2	1 1/2	5 5/8	3 1/8	3 1/2	3 1/2	
	4	3-12	3 3/4-12	4	4 3/4	1	Δ	1/2	1 1/2	1 1/2	6 7/16	3 1/8	3 1/2	3 1/2	
	4 1/2	3 1/4-12	4 1/4-12	4 1/2	5 1/4	1	Δ	1/2	1 1/2	1 1/2	7 1/8	3 1/8	3 1/2	3 1/2	
	5	3 1/2-12	4 3/4-12	5	5 3/4	1	Δ	1/2	1 1/2	1 1/2	7 5/8	3 1/8	3 1/2	3 1/2	
12	5 1/2	4-12	5 1/4-12	5 1/2	6 1/4	1	Δ	1/2	1 1/2	1 1/2	8 3/8	3 1/8	3 1/2	3 1/2	
	2	1 1/2-12	1 3/4-12	2 1/4	2 5/8	7/8	1 3/4	3/8	1 1/4	1 1/2	4	2 7/8	3 1/4	3 1/4	
	2 1/2	1 7/8-12	2 1/4-12	3	3 1/8	1	2 1/8	1/2	1 1/2	1 1/2	4 7/16	3 1/8	3 1/2	3 1/2	
	3	2 1/4-12	2 3/4-12	3 1/2	3 3/4	1	2 5/8	1/2	1 1/2	1 1/2	5 1/4	3 1/8	3 1/2	3 1/2	
	3 1/2	2 1/2-12	3 1/4-12	3 1/2	4 1/4	1	3	1/2	1 1/2	1 1/2	5 5/8	3 1/8	3 1/2	3 1/2	
	4	3-12	3 3/4-12	4	4 3/4	1	Δ	1/2	1 1/2	1 1/2	6 7/16	3 1/8	3 1/2	3 1/2	
	4 1/2	3 1/4-12	4 1/4-12	4 1/2	5 1/4	1	Δ	1/2	1 1/2	1 1/2	7 1/8	3 1/8	3 1/2	3 1/2	
	5	3 1/2-12	4 3/4-12	5	5 3/4	1	Δ	1/2	1 1/2	1 1/2	7 5/8	3 1/8	3 1/2	3 1/2	
14	5 1/2	4-12	5 1/4-12	5 1/2	6 1/4	1	Δ	1/2	1 1/2	1 1/2	8 3/8	3 1/8	3 1/2	3 1/2	
	2 1/2	1 7/8-12	2 1/4-12	3	3 1/8	1	2 1/8	1/2	1 1/2	1 7/8	4 7/16	3 3/8	3 13/16	3 13/16	
	3	2 1/4-12	2 3/4-12	3 1/2	3 3/4	1	2 5/8	1/2	1 1/2	1 7/8	5 1/4	3 3/8	3 13/16	3 13/16	
	3 1/2	2 1/2-12	3 1/4-12	3 1/2	4 1/4	1	3	1/2	1 1/2	1 7/8	5 5/8	3 3/8	3 13/16	3 13/16	
	4	3-12	3 3/4-12	4	4 3/4	1	Δ	1/2	1 1/2	1 7/8	6 7/16	3 3/8	3 13/16	3 13/16	
	4 1/2	3 1/4-12	4 1/4-12	4 1/2	5 1/4	1	Δ	1/2	1 1/2	1 7/8	7 1/8	3 3/8	3 13/16	3 13/16	
	5	3 1/2-12	4 3/4-12	5	5 3/4	1	Δ	1/2	1 1/2	1 7/8	7 5/8	3 3/8	3 13/16	3 13/16	
	5 1/2	4-12	5 1/4-12	5 1/2	6 1/4	1	Δ	1/2	1 1/2	1 7/8	8 3/8	3 3/8	3 13/16	3 13/16	
16	3 1/2	2 1/2-12	3 1/4-12	3 1/2	4 1/4	1	3	1/2	1 1/2	3	5 5/8	4	3 11/16	3 5/8	
	4	3-12	3 3/4-12	4	4 3/4	1	Δ	1/2	1 1/2	3	6 7/16	4	3 11/16	3 5/8	
	4 1/2	3 1/4-12	4 1/4-12	4 1/2	5 1/4	1	Δ	1/2	1 1/2	3	7 1/8	4	3 11/16	3 5/8	
	5	3 1/2-12	4 3/4-12	5	5 3/4	1	Δ	1/2	1 1/2	3	7 5/8	4	3 11/16	3 5/8	
	5 1/2	4-12	5 1/4-12	5 1/2	6 1/4	1	Δ	1/2	1 1/2	3	8 3/8	4	3 11/16	3 5/8	
18	4	3-12	3 3/4-12	4	4 3/4	1	Δ	3/8	1 3/8	3 1/4	6 7/16	4 1/4	3 15/16	4 1/8	
	4 1/2	3 1/4-12	4 1/4-12	4 1/2	5 1/4	1	Δ	3/8	1 3/8	3 1/4	7 1/8	4 1/4	3 15/16	4 1/8	
	5	3 1/2-12	4 3/4-12	5	5 3/4	1	Δ	3/8	1 3/8	3 1/4	7 5/8	4 1/4	3 15/16	4 1/8	
	5 1/2	4-12	5 1/4-12	5 1/2	6 1/4	1	Δ	3/8	1 3/8	3 1/4	8 3/8	4 1/4	3 15/16	4 1/8	
20	4	3-12	3 3/4-12	4	4 3/4	1	Δ	3/8	1 3/8	3 3/4	6 7/16	4 5/8	4 3/16	4 7/16	
	4 1/2	3 1/4-12	4 1/4-12	4 1/2	5 1/4	1	Δ	3/8	1 3/8	3 3/4	7 1/8	4 5/8	4 3/16	4 7/16	
	5	3 1/2-12	4 3/4-12	5	5 3/4	1	Δ	3/8	1 3/8	3 3/4	7 5/8	4 5/8	4 3/16	4 7/16	
	5 1/2	4-12	5 1/4-12	5 1/2	6 1/4	1	Δ	3/8	1 3/8	3 3/4	8 3/8	4 5/8	4 3/16	4 7/16	

† HEAD END PORTS SHALLOW TAPPED

Ω FIXED CUSHIONS FURNISHED AT THE HEAD END IN THESE SIZES

Δ (4) SPANNER HOLES USED INSTEAD OF FLATS ON 4" DIA. AND LARGER RODS

§ THESE CYLINDERS HAVE FULL PLATE RETAINERS. USE "E" DIMENSION INSTEAD OF "RM" - SEE PAGE 42

± B DIMENSION TOLERANCE -.001/ -.003

* SS DIMENSION CHANGES ON DOUBLE ROD CYLINDERS - SEE PAGE 72 FOR DETAILS

SUGGESTED THAT THESE MOUNTS BE KEYED OR PINNED TO PREVENT SHIFTING

φ CONSULT FACTORY FOR THREAD DEPTH



SIDE END LUGS MOUNT

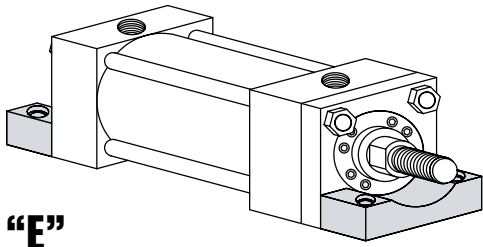

“E”
YATES STYLE E
NFPA-MS7

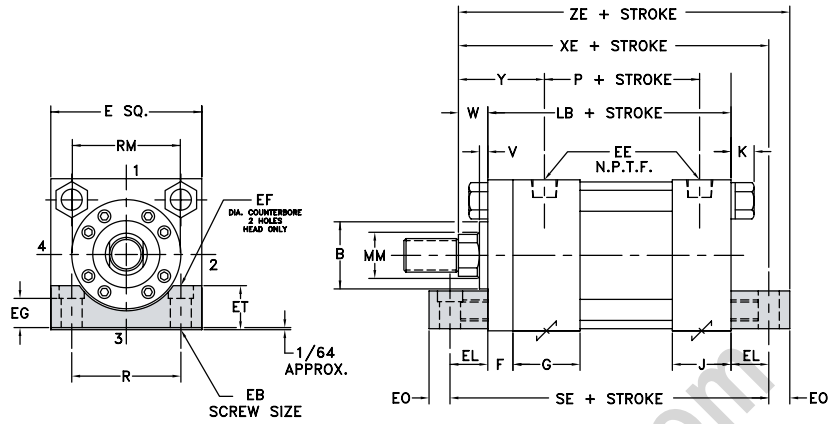

BORE	SAE														ADD STROKE		
	E	EE	OPT	F	G	J	K	EB	EF	EG	EL	EO	ET	R	LB	SE*	P
1 1/2	2	3/8	6	3/8	1 1/2	1	1/4	1/4	1/2	7/16	3/4	1/4	9/16	1.43	4	5 1/2	2 3/16
2	2 1/2	3/8	6	3/8	1 1/2	1	5/16	5/16	1/2	15/32	15/16	5/16	3/4	1.84	4	5 7/8	2 3/16
2 1/2	3	3/8	6	3/8	1 1/2	1	5/16	5/16	1/2	5/8	1 1/16	5/16	7/8	2.19	4 1/8	6 1/4	2 5/16
3 1/4	3 3/4	1/2	10	5/8	1 3/4	1 1/4	3/8	3/8	5/16	11/16	7/8	3/8	1	2.76	4 7/8	6 5/8	2 5/8
4	4 1/2	1/2	10	5/8	1 3/4	1 1/4	3/8	3/8	NA	NA	1	3/8	1 1/4	3.32	4 7/8	6 7/8	2 5/8
5	5 1/2	1/2	10	5/8	1 3/4	1 1/4	7/16	1/2	7/8	1 1/4	1 1/16	1/2	1 1/2	4.10	5 1/8	7 1/4	2 7/8
6	6 1/2	3/4	12	3/4	2	1 1/2	7/16	1/2	7/8	1 1/4	1	1/2	1 5/8	4.88	5 3/4	7 3/4	3 1/8

BORE	ROD DIA. MM	ROD EXTENSIONS AND PILOT DIMENSIONS											ADD STROKE	
		KK	CC	A	B ‡	C	D	V	W	RM	Y	XE *	ZE *	
1 1/2	5/8	7/16-20	1/2-20	3/4	1 1/8	3/8	1/2	1/4	5/8	§	1 31/32	5 3/8	5 5/8	
	1†Ω	3/4-16	7/8-14	1 1/8	1 1/2	1/2	7/8	1/2	1	§	2 11/32	5 3/4	6	
2	5/8	7/16-20	1/2-20	3/4	1 1/8	3/8	1/2	1/4	5/8	§	1 31/32	5 9/16	5 7/8	
	1	3/4-16	7/8-14	1 1/8	1 1/2	1/2	7/8	1/2	1	§	2 11/32	5 15/16	6 1/4	
	1 3/8†Ω	1-14	1 1/4-12	1 5/8	2	5/8	1 1/8	5/8	1 1/4	§	2 19/32	6 3/16	6 1/2	
2 1/2	5/8	7/16-20	1/2-20	3/4	1 1/8	3/8	1/2	1/4	5/8	2 3/8	1 31/32	5 13/16	6 1/8	
	1	3/4-16	7/8-14	1 1/8	1 1/2	1/2	7/8	1/2	1	2 5/8	2 11/32	6 3/16	6 1/2	
	1 3/8	1-14	1 1/4-12	1 5/8	2	5/8	1 1/8	5/8	1 1/4	§	2 19/32	6 7/16	6 3/4	
	1 3/4†Ω	1 1/4-12	1 1/2-12	2	2 3/8	3/4	1 1/2	3/4	1 1/2	§	2 27/32	6 11/16	7	
3 1/4	1	3/4-16	7/8-14	1 1/8	1 1/2	1/2	7/8	1/4	3/4	2 5/8	2 7/16	6 1/2	6 7/8	
	1 3/8	1-14	1 1/4-12	1 5/8	2	5/8	1 1/8	3/8	1	3 7/32	2 11/16	6 3/4	7 1/8	
	1 3/4	1 1/4-12	1 1/2-12	2	2 3/8	3/4	1 1/2	1/2	1 1/4	§	2 15/16	7	7 3/8	
	2†	1 1/2-12	1 3/4-12	2 1/4	2 5/8	7/8	1 3/4	1/2	1 3/8	§	3 1/16	7 1/8	7 1/2	
4	1	3/4-16	7/8-14	1 1/8	1 1/2	1/2	7/8	1/4	3/4	2 5/8	2 7/16	6 5/8	7	
	1 3/8	1-14	1 1/4-12	1 5/8	2	5/8	1 1/8	3/8	1	3 7/32	2 11/16	6 7/8	7 1/4	
	1 3/4	1 1/4-12	1 1/2-12	2	2 3/8	3/4	1 1/2	1/2	1 1/4	3 7/8	2 15/16	7 1/8	7 1/2	
	2	1 1/2-12	1 3/4-12	2 1/4	2 5/8	7/8	1 3/4	1/2	1 3/8	4	3 1/16	7 1/4	7 5/8	
5	2 1/2†	1 7/8-12	2 1/4-12	3	3 1/8	1	2 1/8	5/8	1 5/8	§	3 5/16	7 1/2	7 7/8	
	1	3/4-16	7/8-14	1 1/8	1 1/2	1/2	7/8	1/4	3/4	2 5/8	2 7/16	6 15/16	7 7/16	
	1 3/8	1-14	1 1/4-12	1 5/8	2	5/8	1 1/8	3/8	1	3 7/32	2 11/16	7 3/16	7 11/16	
	1 3/4	1 1/4-12	1 1/2-12	2	2 3/8	3/4	1 1/2	1/2	1 1/4	3 7/8	2 15/16	7 7/16	7 15/16	
	2	1 1/2-12	1 3/4-12	2 1/4	2 5/8	7/8	1 3/4	1/2	1 3/8	4	3 1/16	7 9/16	8 1/16	
6	2 1/2	1 7/8-12	2 1/4-12	3	3 1/8	1	2 1/8	5/8	1 5/8	4 7/16	3 5/16	7 13/16	8 5/16	
	3	2 1/4-12	2 3/4-12	3 1/2	3 3/4	1	2 5/8	5/8	1 5/8	§	3 5/16	7 13/16	8 5/16	
	3 1/2†	2 1/2-12	3 1/4-12	3 1/2	4 1/4	1	3	5/8	1 5/8	§	3 5/16	7 13/16	8 5/16	
	1 3/8	1-14	1 1/4-12	1 5/8	2	5/8	1 1/8	1/4	7/8	3 7/32	2 13/16	7 5/8	8 1/8	
	1 3/4	1 1/4-12	1 1/2-12	2	2 3/8	3/4	1 1/2	3/8	1 1/8	3 7/8	3 1/16	7 7/8	8 3/8	
6	2	1 1/2-12	1 3/4-12	2 1/4	2 5/8	7/8	1 3/4	3/8	1 1/4	4	3 3/16	8	8 1/2	
	2 1/2	1 7/8-12	2 1/4-12	3	3 1/8	1	2 1/8	1/2	1 1/2	4 7/16	3 7/16	8 1/4	8 3/4	
	3	2 1/4-12	2 3/4-12	3 1/2	3 3/4	1	2 5/8	1/2	1 1/2	5 1/4	3 7/16	8 1/4	8 3/4	
	3 1/2	2 1/2-12	3 1/4-12	3 1/2	4 1/4	1	3	1/2	1 1/2	5 5/8	3 7/16	8 1/4	8 3/4	
	4	3-12	3 3/4-12	4	4 3/4	1	ΔΔ	1/2	1 1/2	§	3 7/16	8 1/4	8 3/4	



STANDARD ROD ENDS

#2 STD MALE NFPA-SM

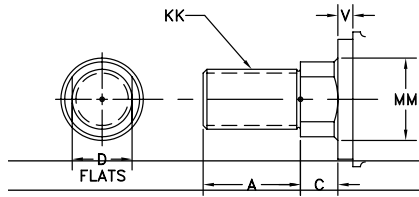

#4 STD FEMALE NFPA-SF

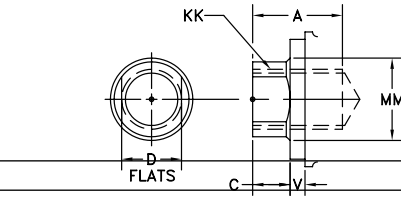

#1 MALE NFPA-IM

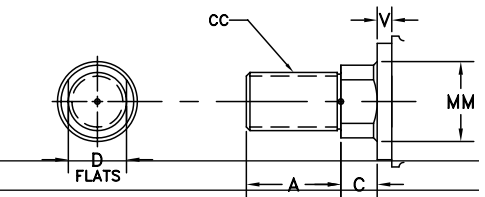

BORE	SAE															ADD STROKE		
	E	EE	OPT	F	G	J	K	EB	EF	EG	EL	EO	ET	R	LB	SE*	P	
8	8 1/2	3/4	12	3/4	2	1 1/2	9/16	5/8	NA	NA	1 1/8	5/8	2	6.44	5 7/8	7 3/8	3 1/4	
10	10 5/8	1	16	3/4	2 1/4	2	11/16	3/4	NA	NA	1 5/16	5/8	2 3/4	7.92	7 1/8	9	4 1/8	
12	12 3/4	1	16	3/4	2 1/4	2	11/16	3/4	NA	NA	1 5/16	5/8	3 7/16	9.40	7 5/8	9 1/2	4 5/8	
14	14 3/4	1 1/4	20	3/4	2 3/4	2 1/4	13/16	7/8	NA	NA	1 1/2	3/4	3 7/8	10.90	8 7/8	11 1/8	5 1/2	

BORE	ROD DIA.	ROD EXTENSIONS AND PILOT DIMENSIONS											ADD STROKE	
	MM	KK	CC	A	B	C	D	V	W	RM	Y	XE*	ZE*	
8	1 3/8	1-14	1 1/4-12	1 5/8	2	5/8	1 1/8	1/4	7/8	3 7/32	2 13/16	7 7/8	8 1/2	
	1 3/4	1 1/4-12	1 1/2-12	2	2 3/8	3/4	1 1/2	3/8	1 1/8	3 7/8	3 1/16	8 1/8	8 3/4	
	2	1 1/2-12	1 3/4-12	2 1/4	2 5/8	7/8	1 3/4	3/8	1 1/4	4	3 3/16	8 1/4	8 7/8	
	2 1/2	1 7/8-12	2 1/4-12	3	3 1/8	1	2 1/8	1/2	1 1/2	4 7/16	3 7/16	8 1/2	9 1/8	
	3	2 1/4-12	2 3/4-12	3 1/2	3 3/4	1	2 5/8	1/2	1 1/2	5 1/4	3 7/16	8 1/2	9 1/8	
	3 1/2	2 1/2-12	3 1/4-12	3 1/2	4 1/4	1	3	1/2	1 1/2	5 5/8	3 7/16	8 1/2	9 1/8	
	4	3-12	3 3/4-12	4	4 3/4	1	Δ	1/2	1 1/2	6 7/16	3 7/16	8 1/2	9 1/8	
	4 1/2	3 1/4-12	4 1/4-12	4 1/2	5 1/4	1	Δ	1/2	1 1/2	7 1/8	3 7/16	8 1/2	9 1/8	
10	5	3 1/2-12	4 3/4-12	5	5 3/4	1	Δ	1/2	1 1/2	7 5/8	3 7/16	8 1/2	9 1/8	
	1 3/4	1 1/4-12	1 1/2-12	2	2 3/8	3/4	1 1/2	3/8	1 1/8	3 7/8	3 1/8	9 9/16	10 3/16	
	2	1 1/2-12	1 3/4-12	2 1/4	2 5/8	7/8	1 3/4	3/8	1 1/4	4	3 1/4	9 11/16	10 5/16	
	2 1/2	1 7/8-12	2 1/4-12	3	3 1/8	1	2 1/8	1/2	1 1/2	4 7/16	3 1/2	9 15/16	10 9/16	
	3	2 1/4-12	2 3/4-12	3 1/2	3 3/4	1	2 5/8	1/2	1 1/2	5 1/4	3 1/2	9 15/16	10 9/16	
	3 1/2	2 1/2-12	3 1/4-12	3 1/2	4 1/4	1	3	1/2	1 1/2	5 5/8	3 1/2	9 15/16	10 9/16	
	4	3-12	3 3/4-12	4	4 3/4	1	Δ	1/2	1 1/2	6 7/16	3 1/2	9 15/16	10 9/16	
	4 1/2	3 1/4-12	4 1/4-12	4 1/2	5 1/4	1	Δ	1/2	1 1/2	7 1/8	3 1/2	9 15/16	10 9/16	
12	5	3 1/2-12	4 3/4-12	5	5 3/4	1	Δ	1/2	1 1/2	7 5/8	3 1/2	9 15/16	10 9/16	
	5 1/2	4-12	5 1/4-12	5 1/2	6 1/4	1	Δ	1/2	1 1/2	8 3/8	3 1/2	9 15/16	10 9/16	
	2	1 1/2-12	1 3/4-12	2 1/4	2 5/8	7/8	1 3/4	3/8	1 1/4	4	3 1/4	10 3/16	10 13/16	
	2 1/2	1 7/8-12	2 1/4-12	3	3 1/8	1	2 1/8	1/2	1 1/2	4 7/16	3 1/2	10 7/16	11 1/16	
	3	2 1/4-12	2 3/4-12	3 1/2	3 3/4	1	2 5/8	1/2	1 1/2	5 1/4	3 1/2	10 7/16	11 1/16	
	3 1/2	2 1/2-12	3 1/4-12	3 1/2	4 1/4	1	3	1/2	1 1/2	5 5/8	3 1/2	10 7/16	11 1/16	
	4	3-12	3 3/4-12	4	4 3/4	1	Δ	1/2	1 1/2	6 7/16	3 1/2	10 7/16	11 1/16	
	4 1/2	3 1/4-12	4 1/4-12	4 1/2	5 1/4	1	Δ	1/2	1 1/2	7 1/8	3 1/2	10 7/16	11 1/16	
14	5	3 1/2-12	4 3/4-12	5	5 3/4	1	Δ	1/2	1 1/2	7 5/8	3 1/2	10 7/16	11 1/16	
	5 1/2	4-12	5 1/4-12	5 1/2	6 1/4	1	Δ	1/2	1 1/2	8 3/8	3 1/2	10 7/16	11 1/16	
	2 1/2	1 7/8-12	2 1/4-12	3	3 1/8	1	2 1/8	1/2	1 1/2	4 7/16	3 13/16	11 7/8	12 5/8	
	3	2 1/4-12	2 3/4-12	3 1/2	3 3/4	1	2 5/8	1/2	1 1/2	5 1/4	3 13/16	11 7/8	12 5/8	
	3 1/2	2 1/2-12	3 1/4-12	3 1/2	4 1/4	1	3	1/2	1 1/2	5 5/8	3 13/16	11 7/8	12 5/8	
	4	3-12	3 3/4-12	4	4 3/4	1	Δ	1/2	1 1/2	6 7/16	3 13/16	11 7/8	12 5/8	
	4 1/2	3 1/4-12	4 1/4-12	4 1/2	5 1/4	1	Δ	1/2	1 1/2	7 1/8	3 13/16	11 7/8	12 5/8	
	5	3 1/2-12	4 3/4-12	5	5 3/4	1	Δ	1/2	1 1/2	7 5/8	3 13/16	11 7/8	12 5/8	
5 1/2	4-12	5 1/4-12	5 1/2	6 1/4	1	Δ	1/2	1 1/2	8 3/8	3 13/16	11 7/8	12 5/8		

† HEAD END PORTS SHALLOW TAPPED
 Ω FIXED CUSHIONS FURNISHED AT THE HEAD END IN THESE SIZES
 Δ (4) SPANNER HOLES USED INSTEAD OF FLATS ON 4" DIA. AND LARGER RODS
 ■ MOUNT "E" NOT AVAILABLE WITH STD DIMENSIONS.
 § THESE CYLINDERS HAVE FULL PLATE RETAINERS. USE "E" DIMENSION INSTEAD OF "RM" - SEE PAGE 42
 ‡ B DIMENSION TOLERANCE -.001/ -.003
 * SE, XE & ZE DIMENSION CHANGES ON DOUBLE ROD CYLINDERS - SEE PAGE 72 FOR DETAILS

NOTE: SUGGESTED THAT THESE MOUNTS BE KEYPED OR PINNED TO PREVENT SHIFTING
NOTE: BOTTOMS OF HEAD AND CAP ARE MOUNTING SURFACES. LUGS HOLD CYLINDER AGAINST MOUNTING SURFACE
NOTE: CHECK FOR CLEARANCE BETWEEN FRONT MOUNTING LUG AND ROD END ATTACHMENT. SPECIFY LONGER THAN STANDARD "W" DIMENSION IF NECESSARY.



SPHERICAL BEARING MOUNT

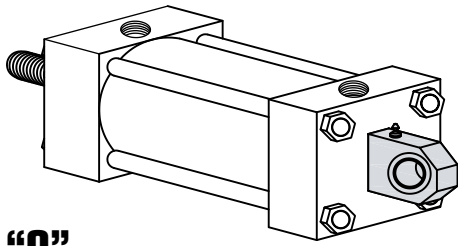

“Q”
YATES STYLE Q
NFPA-MPU3

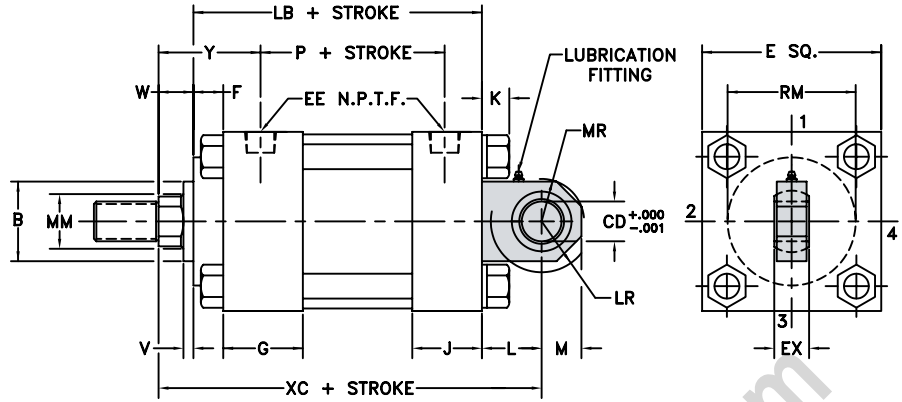

BORE	SAE													ADD STROKE	
	E	EE	OPT	F	G	J	K	CD	EX	L	LR	M	MR	LB	P
1 1/2	2	3/8	6	3/8	1 1/2	1	1/4	1/2	7/16	3/4	9/16	3/4	13/16	4	2 3/16
2	2 1/2	3/8	6	3/8	1 1/2	1	5/16	1/2	7/16	3/4	9/16	3/4	13/16	4	2 3/16
2 1/2	3	3/8	6	3/8	1 1/2	1	5/16	1/2	7/16	3/4	9/16	3/4	13/16	4 1/8	2 5/16
3 1/4	3 3/4	1/2	10	5/8	1 3/4	1 1/4	3/8	3/4	21/32	1 1/4	1 1/16	1	1 1/8	4 7/8	2 5/8
4	4 1/2	1/2	10	5/8	1 3/4	1 1/4	3/8	3/4	21/32	1 1/4	1 1/16	1	1 1/8	4 7/8	2 5/8
5	5 1/2	1/2	10	5/8	1 3/4	1 1/4	7/16	3/4	21/32	1 1/4	1 1/16	1	1 1/8	5 1/8	2 7/8
6	6 1/2	3/4	10	3/4	2	1 1/2	7/16	1	7/8	1 1/2	1 5/16	1 1/4	1 3/8	5 3/4	3 1/8

BORE	ROD DIA. MM	ROD EXTENSIONS AND PILOT DIMENSIONS											ADD STROKE XC	MAX PSI
		KK	CC	A	B†	C	D	V	W	Y	RM			
1 1/2	5/8	7/16-20	1/2-20	3/4	1 1/8	3/8	1/2	1/4	5/8	1 31/32	§	5 3/8	1675	
	1†Ω	3/4-16	7/8-14	1 1/8	1 1/2	1/2	7/8	1/2	1	2 11/32	§	5 3/4		
2	5/8	7/16-20	1/2-20	3/4	1 1/8	3/8	1/2	1/4	5/8	1 31/32	§	5 3/8	950	
	1	3/4-16	7/8-14	1 1/8	1 1/2	1/2	7/8	1/2	1	2 11/32	§	5 3/4		
2 1/2	1 3/8†Ω	1-14	1 1/4-12	1 5/8	2	5/8	1 1/8	5/8	1 1/4	2 19/32	§	6	610	
	5/8	7/16-20	1/2-20	3/4	1 1/8	3/8	1/2	1/4	5/8	1 31/32	2 3/8	5 1/2		
	1	3/4-16	7/8-14	1 1/8	1 1/2	1/2	7/8	1/2	1	2 11/32	2 5/8	5 7/8		
3 1/4	1 3/8	1-14	1 1/4-12	1 5/8	2	5/8	1 1/8	5/8	1 1/4	2 19/32	§	6 1/8	840	
	1 3/4	1 1/4-12	1 1/2-12	2	2 3/8	3/4	1 1/2	3/4	1 1/2	2 27/32	§	6 3/8		
	2†	1 1/2-12	1 3/4-12	2 1/4	2 5/8	7/8	1 3/4	1/2	1 3/8	3 1/16	§	7 1/2		
	1	3/4-16	7/8-14	1 1/8	1 1/2	1/2	7/8	1/4	3/4	2 7/16	2 5/8	6 7/8		
4	1 3/8	1-14	1 1/4-12	1 5/8	2	5/8	1 1/8	3/8	1	2 11/16	3 7/32	7 1/8	555	
	1 3/4	1 1/4-12	1 1/2-12	2	2 3/8	3/4	1 1/2	1/2	1 1/4	2 15/16	§	7 3/8		
	2	1 1/2-12	1 3/4-12	2 1/4	2 5/8	7/8	1 3/4	1/2	1 3/8	3 1/16	4	7 1/2		
	2 1/2†	1 7/8-12	2 1/4-12	3	3 1/8	1	2 1/8	5/8	1 5/8	3 5/16	§	7 3/4		
	1	3/4-16	7/8-14	1 1/8	1 1/2	1/2	7/8	1/4	3/4	2 7/16	2 5/8	7 1/8		
5	1 3/8	1-14	1 1/4-12	1 5/8	2	5/8	1 1/8	3/8	1	2 11/16	3 7/32	7 3/8	360	
	1 3/4	1 1/4-12	1 1/2-12	2	2 3/8	3/4	1 1/2	1/2	1 1/4	2 15/16	3 7/8	7 5/8		
	2	1 1/2-12	1 3/4-12	2 1/4	2 5/8	7/8	1 3/4	1/2	1 3/8	3 1/16	4	7 3/4		
	2 1/2	1 7/8-12	2 1/4-12	3	3 1/8	1	2 1/8	5/8	1 5/8	3 5/16	4 7/16	8		
	3	2 1/4-12	2 3/4-12	3 1/2	3 3/4	1	2 5/8	5/8	1 5/8	3 5/16	§	8		
	3 1/2†	2 1/2-12	3 1/4-12	3 1/2	4 1/4	1	3	5/8	1 5/8	3 5/16	§	8		
6	1 3/8	1-14	1 1/4-12	1 5/8	2	5/8	1 1/8	1/4	7/8	2 13/16	3 7/32	8 1/8	440	
	1 3/4	1 1/4-12	1 1/2-12	2	2 3/8	3/4	1 1/2	3/8	1 1/8	3 1/16	3 7/8	8 3/8		
	2	1 1/2-12	1 3/4-12	2 1/4	2 5/8	7/8	1 3/4	3/8	1 1/4	3 3/16	4	8 1/2		
	2 1/2	1 7/8-12	2 1/4-12	3	3 1/8	1	2 1/8	1/2	1 1/2	3 7/16	4 7/16	8 3/4		
	3	2 1/4-12	2 3/4-12	3 1/2	3 3/4	1	2 5/8	1/2	1 1/2	3 7/16	5 1/4	8 3/4		
	3 1/2	2 1/2-12	3 1/4-12	3 1/2	4 1/4	1	3	1/2	1 1/2	3 7/16	5 5/8	8 3/4		
	4	3-12	3 3/4-12	4	4 3/4	1	Δ	1/2	1 1/2	3 7/16	§	8 3/4		



STANDARD ROD ENDS

#2 STD MALE NFPA-SM

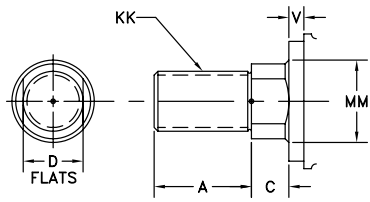

#4 STD FEMALE NFPA-SF

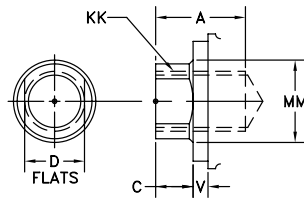

#1 MALE NFPA-IM

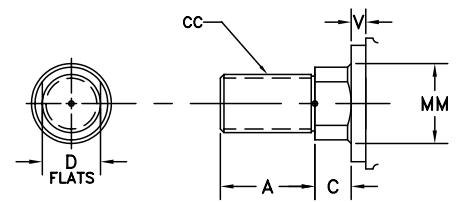

BORE	SAE													ADD STROKE	
	E	EE	OPT	F	G	J	K	CD	EX	L	LR	M	MR	LB	P
8	8 1/2	3/4	12	3/4	2	1 1/2	9/16	1	7/8	1 1/2	1 5/16	1 1/4	1 3/8	5 7/8	3 1/4
10	10 5/8	1	24	3/4	2 1/4	2	11/16	1 3/8	1 3/16	2 1/8	1 13/16	1 7/8	2 1/16	7 1/8	4 1/8
12	12 3/4	1	24	3/4	2 1/4	2	11/16	1 3/4	1 17/32	2 1/4	1 15/16	2 1/2	2 3/4	7 5/8	4 5/8
14	14 3/4	1 1/4	24	3/4	2 3/4	2 1/4	13/16	2	1 3/4	2 1/2	2 3/16	2 1/2	2 3/4	8 7/8	5 1/2

BORE	ROD DIA. MM	ROD EXTENSIONS AND PILOT DIMENSIONS											ADD STROKE XC	MAX. PSI
		KK	CC	A	B†	C	D	V	W	Y	RM			
8	1 3/8	1-14	1 1/4-12	1 5/8	2	5/8	1 1/8	1/4	7/8	2 13/16	3 7/32	8 1/4	250	
	1 3/4	1 1/4-12	1 1/2-12	2	2 3/8	3/4	1 1/2	3/8	1 1/8	3 1/16	3 7/8	8 1/2		
	2	1 1/2-12	1 3/4-12	2 1/4	2 5/8	7/8	1 3/4	3/8	1 1/4	3 3/16	4	8 5/8		
	2 1/2	1 7/8-12	2 1/4-12	3	3 1/8	1	2 1/8	1/2	1 1/2	3 7/16	4 7/16	8 7/8		
	3	2 1/4-12	2 3/4-12	3 1/2	3 3/4	1	2 5/8	1/2	1 1/2	3 7/16	5 1/4	8 7/8		
	3 1/2	2 1/2-12	3 1/4-12	3 1/2	4 1/4	1	3	1/2	1 1/2	3 7/16	5 5/8	8 7/8		
	4	3-12	3 3/4-12	4	4 3/4	1	Δ	1/2	1 1/2	3 7/16	6 7/16	8 7/8		
	4 1/2	3 1/4-12	4 1/4-12	4 1/2	5 1/4	1	Δ	1/2	1 1/2	3 7/16	7 1/8	8 7/8		
5	3 1/2-12	4 3/4-12	5	5 3/4	1	Δ	1/2	1 1/2	3 7/16	7 5/8	8 7/8			
10	1 3/4	1 1/4-12	1 1/2-12	2	2 3/8	3/4	1 1/2	3/8	1 1/8	3 1/8	3 7/8	10 3/8	250	
	2	1 1/2-12	1 3/4-12	2 1/4	2 5/8	7/8	1 3/4	3/8	1 1/4	3 1/4	4	10 1/2		
	2 1/2	1 7/8-12	2 1/4-12	3	3 1/8	1	2 1/8	1/2	1 1/2	3 1/2	4 7/16	10 3/4		
	3	2 1/4-12	2 3/4-12	3 1/2	3 3/4	1	2 5/8	1/2	1 1/2	3 1/2	5 1/4	10 3/4		
	3 1/2	2 1/2-12	3 1/4-12	3 1/2	4 1/4	1	3	1/2	1 1/2	3 1/2	5 5/8	10 3/4		
	4	3-12	3 3/4-12	4	4 3/4	1	Δ	1/2	1 1/2	3 1/2	6 7/16	10 3/4		
	4 1/2	3 1/4-12	4 1/4-12	4 1/2	5 1/4	1	Δ	1/2	1 1/2	3 1/2	7 1/8	10 3/4		
	5	3 1/2-12	4 3/4-12	5	5 3/4	1	Δ	1/2	1 1/2	3 1/2	7 5/8	10 3/4		
5 1/2	4-12	5 1/4-12	5 1/2	6 1/4	1	Δ	1/2	1 1/2	3 1/2	8 3/8	10 3/4			
12	2	1 1/2-12	1 3/4-12	2 1/4	2 5/8	7/8	1 3/4	3/8	1 1/4	3 1/4	4	11 1/8	250	
	2 1/2	1 7/8-12	2 1/4-12	3	3 1/8	1	2 1/8	1/2	1 1/2	3 1/2	4 7/16	11 3/8		
	3	2 1/4-12	2 3/4-12	3 1/2	3 3/4	1	2 5/8	1/2	1 1/2	3 1/2	5 1/4	11 3/8		
	3 1/2	2 1/2-12	3 1/4-12	3 1/2	4 1/4	1	3	1/2	1 1/2	3 1/2	5 5/8	11 3/8		
	4	3-12	3 3/4-12	4	4 3/4	1	Δ	1/2	1 1/2	3 1/2	6 7/16	11 3/8		
	4 1/2	3 1/4-12	4 1/4-12	4 1/2	5 1/4	1	Δ	1/2	1 1/2	3 1/2	7 1/8	11 3/8		
	5	3 1/2-12	4 3/4-12	5	5 3/4	1	Δ	1/2	1 1/2	3 1/2	7 5/8	11 3/8		
	5 1/2	4-12	5 1/4-12	5 1/2	6 1/4	1	Δ	1/2	1 1/2	3 1/2	8 3/8	11 3/8		
14	2 1/2	1 7/8-12	2 1/4-12	3	3 1/8	1	2 1/8	1/2	1 1/2	3 13/16	4 7/16	12 7/8	250	
	3	2 1/4-12	2 3/4-12	3 1/2	3 3/4	1	2 5/8	1/2	1 1/2	3 13/16	5 1/4	12 7/8		
	3 1/2	2 1/2-12	3 1/4-12	3 1/2	4 1/4	1	3	1/2	1 1/2	3 13/16	5 5/8	12 7/8		
	4	3-12	3 3/4-12	4	4 3/4	1	Δ	1/2	1 1/2	3 13/16	6 7/16	12 7/8		
	4 1/2	3 1/4-12	4 1/4-12	4 1/2	5 1/4	1	Δ	1/2	1 1/2	3 13/16	7 1/8	12 7/8		
	5	3 1/2-12	4 3/4-12	5	5 3/4	1	Δ	1/2	1 1/2	3 13/16	7 5/8	12 7/8		
	5 1/2	4-12	5 1/4-12	5 1/2	6 1/4	1	Δ	1/2	1 1/2	3 13/16	8 3/8	12 7/8		

† HEAD END PORTS SHALLOW TAPPED
 Ω FIXED CUSHIONS FURNISHED AT THE HEAD END IN THESE SIZES
 Δ (4) SPANNER HOLES USED INSTEAD OF FLATS ON 4" DIA. AND LARGER RODS
 § THESE CYLINDERS HAVE FULL PLATE RETAINERS. USE "E" DIMENSION INSTEAD OF "RM" - SEE PAGE 42
 ‡ B DIMENSION TOLERANCE -.001/-.003



CAP FIXED CLEVIS MOUNT

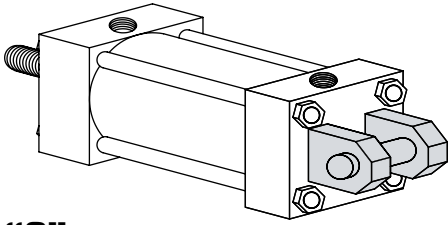

“C”
YATES STYLE C
NFPA-MP1

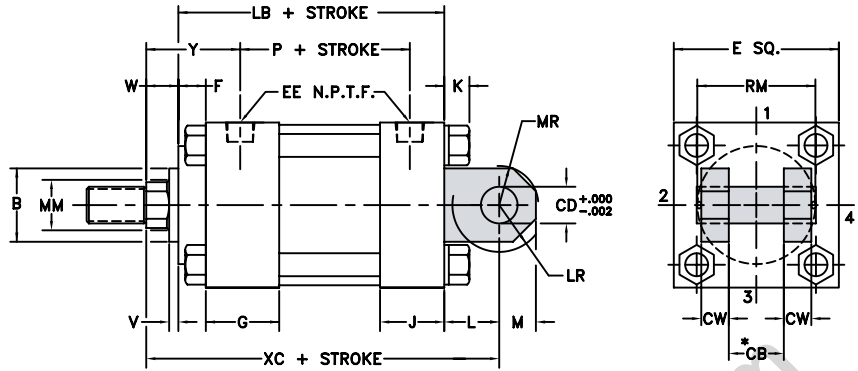

CAP FIXED EYE MOUNT

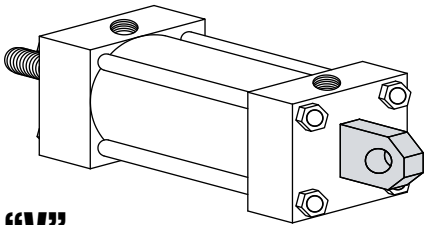

“V”
YATES STYLE V
NFPA-MP3

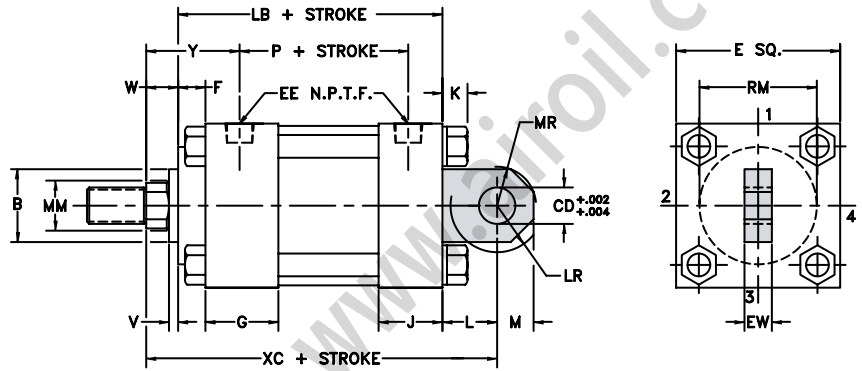

STANDARD ROD ENDS

#2 STD MALE
NFPA-SM

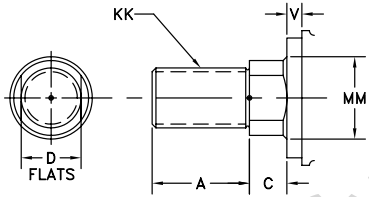

#4 STD FEMALE
NFPA-SF

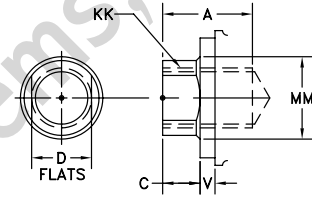

#1 MALE
NFPA-IM

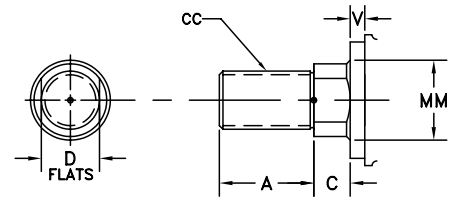

BORE	SAE															ADD STROKE	
	E	EE	OPT	F	G	J	K	CB *	CD	CW	EW Ø	L	LR	M	MR	LB	P
1 1/2	2	3/8	6	3/8	1 1/2	1	1/4	3/4	1/2	1/2	3/4	3/4	9/16	1/2	9/16	4	2 3/16
2	2 1/2	3/8	6	3/8	1 1/2	1	5/16	3/4	1/2	1/2	3/4	3/4	9/16	1/2	9/16	4	2 3/16
2 1/2	3	3/8	6	3/8	1 1/2	1	5/16	3/4	1/2	1/2	3/4	3/4	9/16	1/2	9/16	4 1/8	2 5/16
3 1/4	3 3/4	1/2	10	5/8	1 3/4	1 1/4	3/8	1 1/4	3/4	5/8	1 1/4	1 1/4	1 1/16	3/4	7/8	4 7/8	2 5/8
4	4 1/2	1/2	10	5/8	1 3/4	1 1/4	3/8	1 1/4	3/4	5/8	1 1/4	1 1/4	1 1/16	3/4	7/8	4 7/8	2 5/8
5	5 1/2	1/2	10	5/8	1 3/4	1 1/4	7/16	1 1/4	3/4	5/8	1 1/4	1 1/4	1 1/16	3/4	7/8	5 1/8	2 7/8
6	6 1/2	3/4	12	3/4	2	1 1/2	7/16	1 1/2	1	3/4	1 1/2	1 1/2	15/16	1	1 1/8	5 3/4	3 1/8
8	8 1/2	3/4	12	3/4	2	1 1/2	9/16	1 1/2	1	3/4	1 1/2	1 1/2	15/16	1	1 1/8	5 7/8	3 1/4

BORE	ROD DIA. MM	ROD EXTENSIONS AND PILOT DIMENSIONS												ADD STROKE	
		KK	CC	A	B ‡	C	D	V	W	Y	RM	XC			
1 1/2	5/8	7/16-20	1/2-20	3/4	1 1/8	3/8	1/2	1/4	5/8	1 31/32	§	5 3/8			
	1†Ω	3/4-16	7/8-14	1 1/8	1 1/2	1/2	7/8	1/2	1	2 11/32	§	5 3/4			
2	5/8	7/16-20	1/2-20	3/4	1 1/8	3/8	1/2	1/4	5/8	1 31/32	§	5 3/8			
	1	3/4-16	7/8-14	1 1/8	1 1/2	1/2	7/8	1/2	1	2 11/32	§	5 3/4			
2 1/2	5/8	7/16-20	1/2-20	3/4	1 1/8	3/8	1/2	1/4	5/8	1 31/32	2 3/8	5 1/2			
	1	3/4-16	7/8-14	1 1/8	1 1/2	1/2	7/8	1/2	1	2 11/32	2 5/8	5 7/8			
3 1/4	1	3/4-16	7/8-14	1 1/8	1 1/2	1/2	7/8	1/4	3/4	2 7/16	2 5/8	6 7/8			
	1 3/8	1-14	1 1/4-12	1 5/8	2	5/8	1 1/8	3/8	1	2 11/16	3 7/32	7 1/8			
4	1 3/8	1-14	1 1/4-12	1 5/8	2	5/8	1 1/8	3/8	1	2 11/16	3 7/32	7 1/8			
	1 3/4	1 1/4-12	1 1/2-12	2	2 3/8	3/4	1 1/2	1/2	1 1/4	2 15/16	§	7 3/8			
5	2†	1 1/2-12	1 3/4-12	2 1/4	2 5/8	7/8	1 3/4	1/2	1 3/8	3 1/16	§	7 1/2			
	1	3/4-16	7/8-14	1 1/8	1 1/2	1/2	7/8	1/4	3/4	2 7/16	2 5/8	6 7/8			
6	1 3/8	1-14	1 1/4-12	1 5/8	2	5/8	1 1/8	3/8	1	2 11/16	3 7/32	7 1/8			
	1 3/4	1 1/4-12	1 1/2-12	2	2 3/8	3/4	1 1/2	1/2	1 1/4	2 15/16	3 7/8	7 5/8			
8	2	1 1/2-12	1 3/4-12	2 1/4	2 5/8	7/8	1 3/4	1/2	1 3/8	3 1/16	4	7 3/4			
	2 1/2	1 7/8-12	2 1/4-12	3	3 1/8	1	2 1/8	5/8	1 5/8	3 5/16	4 7/16	8			
10	3	2 1/4-12	2 3/4-12	3 1/2	3 3/4	1	2 5/8	5/8	1 5/8	3 5/16	§	8			
	3 1/2†	2 1/2-12	3 1/4-12	3 1/2	4 1/4	1	3	5/8	1 5/8	3 5/16	§	8			
12	1 3/8	1-14	1 1/4-12	1 5/8	2	5/8	1 1/8	1/4	7/8	2 13/16	3 7/32	8 1/4			
	1 3/4	1 1/4-12	1 1/2-12	2	2 3/8	3/4	1 1/2	3/8	1 1/8	3 1/16	3 7/8	8 3/8			
14	2	1 1/2-12	1 3/4-12	2 1/4	2 5/8	7/8	1 3/4	3/8	1 1/4	3 3/16	4	8 1/2			
	2 1/2	1 7/8-12	2 1/4-12	3	3 1/8	1	2 1/8	1/2	1 1/2	3 7/16	4 7/16	8 3/4			
16	3	2 1/4-12	2 3/4-12	3 1/2	3 3/4	1	2 5/8	1/2	1 1/2	3 7/16	5 1/4	8 3/4			
	3 1/2	2 1/2-12	3 1/4-12	3 1/2	4 1/4	1	3	1/2	1 1/2	3 7/16	5 5/8	8 3/4			
18	4	3-12	3 3/4-12	4	4 3/4	1	Δ	1/2	1 1/2	3 7/16	§	8 3/4			
	4 1/2	3 1/4-12	4 1/4-12	4 1/2	5 1/4	1	Δ	1/2	1 1/2	3 7/16	7 1/8	8 7/8			
20	5	3 1/2-12	4 3/4-12	5	5 3/4	1	Δ	1/2	1 1/2	3 7/16	7 5/8	8 7/8			

† HEAD END PORTS SHALLOW TAPPED
Ω FIXED CUSHIONS FURNISHED AT THE HEAD END IN THESE SIZES
Δ (4) SPANNER HOLES USED INSTEAD OF FLATS ON 4" DIA. AND LARGER RODS
§ THESE CYLINDERS HAVE FULL PLATE RETAINERS. USE "E" DIMENSION INSTEAD OF "RM" - SEE PAGE 42
‡ B DIMENSION TOLERANCE -.001/- .003
* MAX WIDTH OF MATING PART
⊕ EYE DESIGNED TO FIT YATES STD CLEVIS BRACKET



1 1/2 THRU 8 BORE • SERIES A4/L4/H4

BIG BORE CYLINDERS ON NEXT PAGE

CAP FIXED CLEVIS MOUNT

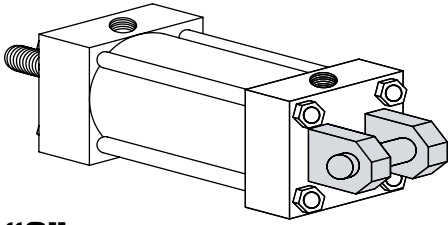

“C”
YATES STYLE C
NFPA-MP1

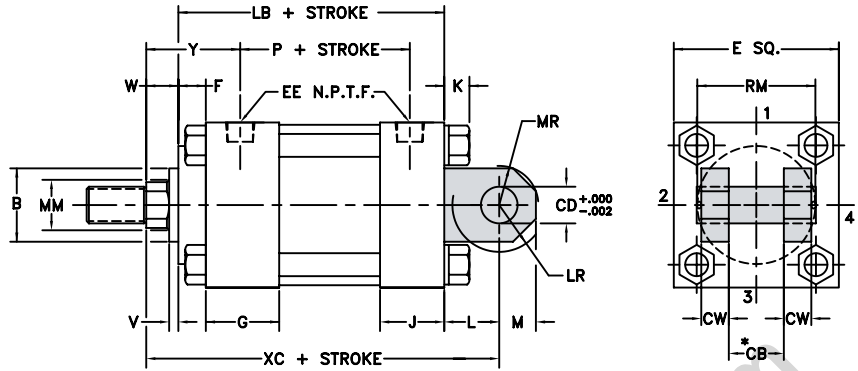

CAP FIXED EYE MOUNT

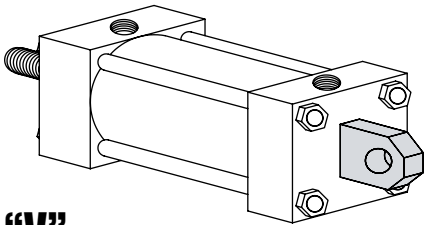

“V”
YATES STYLE V
NFPA-MP3

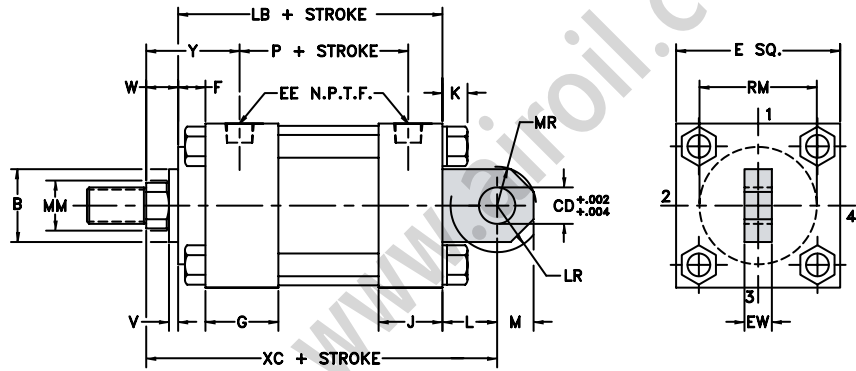

STANDARD ROD ENDS

#2 STD MALE
NFPA-SM

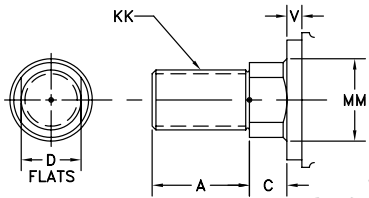

#4 STD FEMALE
NFPA-SF

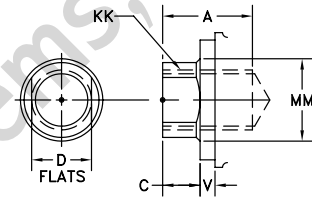

#1 MALE
NFPA-IM

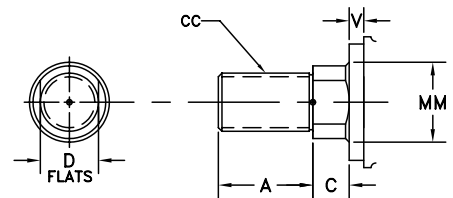

BORE	SAE															ADD STROKE	
	E	EE	OPT	F	G	J	K	CB *	CD	CW	EW Ø	L	LR	M	MR	LB	P
10	10 5/8	1	16	3/4	2 1/4	2	11/16	2	1 3/8	1	2	2 1/8	1 13/16	1 3/8	1 1/2	7 1/8	4 1/8
12	12 3/4	1	16	3/4	2 1/4	2	11/16	2 1/2	1 3/4	1 1/4	2 1/2	2 1/4	1 15/16	1 3/4	1 7/8	7 5/8	4 5/8
14	14 3/4	1 1/4	20	3/4	2 3/4	2 1/4	13/16	2 1/2	2	1 1/4	2 1/2	2 1/2	2 3/16	2	2 3/16	8 7/8	5 1/2
16	17 1/2	1 1/2	24	3/4	2 15/16	2 15/16	15/16	2 1/2	2	1 3/4	2 1/2	3 1/2	3	2 3/4	3	10	6 1/2
18	19 1/2	1 1/2	24	7/8	3 7/16	3 7/16	1	3	2 1/2	2	3	4 1/4	3 3/4	3 1/4	3 1/2	11 1/8	6 1/2
20	21 3/4	2	32	7/8	3 15/16	3 15/16	1 1/8	3	2 1/2	2	3	4 3/4	4 1/4	3 3/4	4 1/16	12 5/8	7 3/8

BORE	ROD DIA. MM	ROD EXTENSIONS AND PILOT DIMENSIONS											ADD STROKE	
		KK	CC	A	B	C	D	V	W	Y	RM	XC		
10	1 3/4	1 1/4-12	1 1/2-12	2	2 3/8	3/4	1 1/2	3/8	1 1/8	3 1/8	3 7/8	10 3/8		
	2	1 1/2-12	1 3/4-12	2 1/4	2 5/8	7/8	1 3/4	3/8	1 1/4	3 1/4	4	10 1/2		
	2 1/2	1 7/8-12	2 1/4-12	3	3 1/8	1	2 1/8	1/2	1 1/2	3 1/2	4 7/16	10 3/4		
	3	2 1/4-12	2 3/4-12	3 1/2	3 3/4	1	2 5/8	1/2	1 1/2	3 1/2	5 1/4	10 3/4		
	3 1/2	2 1/2-12	3 1/4-12	3 1/2	4 1/4	1	3	1/2	1 1/2	3 1/2	5 5/8	10 3/4		
	4	3-12	3 3/4-12	4	4 3/4	1	Δ	1/2	1 1/2	3 1/2	6 7/16	10 3/4		
	4 1/2	3 1/4-12	4 1/4-12	4 1/2	5 1/4	1	Δ	1/2	1 1/2	3 1/2	7 1/8	10 3/4		
	5	3 1/2-12	4 3/4-12	5	5 3/4	1	Δ	1/2	1 1/2	3 1/2	7 5/8	10 3/4		
	5 1/2	4-12	5 1/4-12	5 1/2	6 1/4	1	Δ	1/2	1 1/2	3 1/2	8 3/8	10 3/4		
	12	2	1 1/2-12	1 3/4-12	2 1/4	2 5/8	7/8	1 3/4	3/8	1 1/4	3 1/4	4	11 1/8	
2 1/2		1 7/8-12	2 1/4-12	3	3 1/8	1	2 1/8	1/2	1 1/2	3 1/2	4 7/16	11 3/8		
3		2 1/4-12	2 3/4-12	3 1/2	3 3/4	1	2 5/8	1/2	1 1/2	3 1/2	5 1/4	11 3/8		
3 1/2		2 1/2-12	3 1/4-12	3 1/2	4 1/4	1	3	1/2	1 1/2	3 1/2	5 5/8	11 3/8		
4		3-12	3 3/4-12	4	4 3/4	1	Δ	1/2	1 1/2	3 1/2	6 7/16	11 3/8		
4 1/2		3 1/4-12	4 1/4-12	4 1/2	5 1/4	1	Δ	1/2	1 1/2	3 1/2	7 1/8	11 3/8		
5		3 1/2-12	4 3/4-12	5	5 3/4	1	Δ	1/2	1 1/2	3 1/2	7 5/8	11 3/8		
5 1/2		4-12	5 1/4-12	5 1/2	6 1/4	1	Δ	1/2	1 1/2	3 1/2	8 3/8	11 3/8		
14		2 1/2	1 7/8-12	2 1/4-12	3	3 1/8	1	2 1/8	1/2	1 1/2	3 13/16	4 7/16	12 7/8	
		3	2 1/4-12	2 3/4-12	3 1/2	3 3/4	1	2 5/8	1/2	1 1/2	3 13/16	5 1/4	12 7/8	
	3 1/2	2 1/2-12	3 1/4-12	3 1/2	4 1/4	1	3	1/2	1 1/2	3 13/16	5 5/8	12 7/8		
	4	3-12	3 3/4-12	4	4 3/4	1	Δ	1/2	1 1/2	3 13/16	6 7/16	12 7/8		
	4 1/2	3 1/4-12	4 1/4-12	4 1/2	5 1/4	1	Δ	1/2	1 1/2	3 13/16	7 1/8	12 7/8		
	5	3 1/2-12	4 3/4-12	5	5 3/4	1	Δ	1/2	1 1/2	3 13/16	7 5/8	12 7/8		
	5 1/2	4-12	5 1/4-12	5 1/2	6 1/4	1	Δ	1/2	1 1/2	3 13/16	8 3/8	12 7/8		
	16	3 1/2	2 1/2-12	3 1/4-12	3 1/2	4 1/4	1	3	1/2	1 1/2	3 5/8	5 5/8	15	
		4	3-12	3 3/4-12	4	4 3/4	1	Δ	1/2	1 1/2	3 5/8	6 7/16	15	
		4 1/2	3 1/4-12	4 1/4-12	4 1/2	5 1/4	1	Δ	1/2	1 1/2	3 5/8	7 1/8	15	
5		3 1/2-12	4 3/4-12	5	5 3/4	1	Δ	1/2	1 1/2	3 5/8	7 5/8	15		
5 1/2		4-12	5 1/4-12	5 1/2	6 1/4	1	Δ	1/2	1 1/2	3 5/8	8 3/8	15		
18	4	3-12	3 3/4-12	4	4 3/4	1	Δ	3/8	1 3/8	4 1/8	6 7/16	16 3/4		
	4 1/2	3 1/4-12	4 1/4-12	4 1/2	5 1/4	1	Δ	3/8	1 3/8	4 1/8	7 1/8	16 3/4		
	5	3 1/2-12	4 3/4-12	5	5 3/4	1	Δ	3/8	1 3/8	4 1/8	7 5/8	16 3/4		
	5 1/2	4-12	5 1/4-12	5 1/2	6 1/4	1	Δ	3/8	1 3/8	4 1/8	8 3/8	16 3/4		
20	4	3-12	3 3/4-12	4	4 3/4	1	Δ	3/8	1 3/8	4 7/16	6 7/16	18 3/4		
	4 1/2	3 1/4-12	4 1/4-12	4 1/2	5 1/4	1	Δ	3/8	1 3/8	4 7/16	7 1/8	18 3/4		
	5	3 1/2-12	4 3/4-12	5	5 3/4	1	Δ	3/8	1 3/8	4 7/16	7 5/8	18 3/4		
	5 1/2	4-12	5 1/4-12	5 1/2	6 1/4	1	Δ	3/8	1 3/8	4 7/16	8 3/8	18 3/4		

- † HEAD END PORTS SHALLOW TAPPED
- Ω FIXED CUSHIONS FURNISHED AT THE HEAD END IN THESE SIZES
- Δ (4) SPANNER HOLES USED INSTEAD OF FLATS ON 4" DIA. AND LARGER RODS
- § THESE CYLINDERS HAVE FULL PLATE RETAINERS. USE "E" DIMENSION INSTEAD OF "RM" - SEE PAGE 42
- ‡ B DIMENSION TOLERANCE -.001/ -.003
- * MAX WIDTH OF MATING PART
- ⊕ EYE DESIGNED TO FIT YATES STANDARD CLEVIS BRACKET



CAP DETACHABLE CLEVIS MOUNT

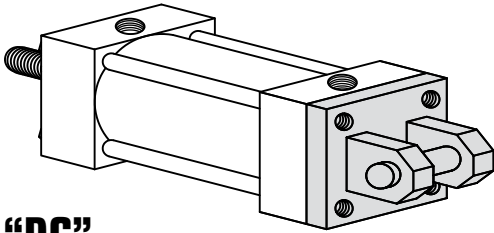

“DC”

YATES STYLE DC
NFPA-MP2

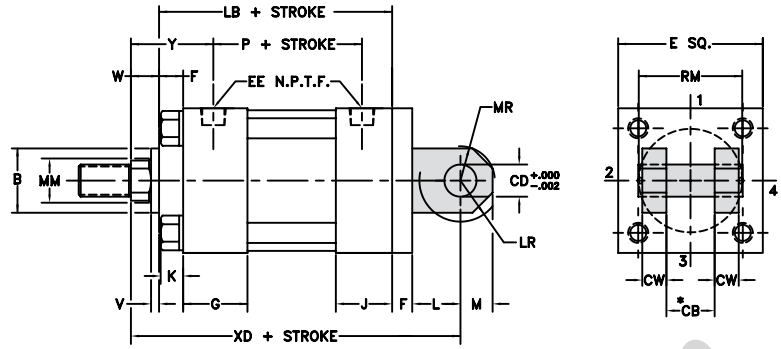

CAP DETACHABLE EYE MOUNT

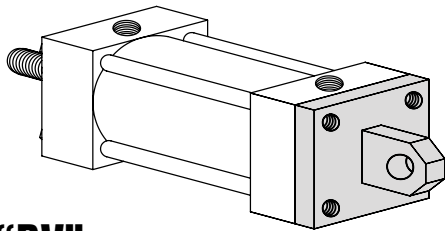

“DV”

YATES STYLE DV
NFPA-MP4

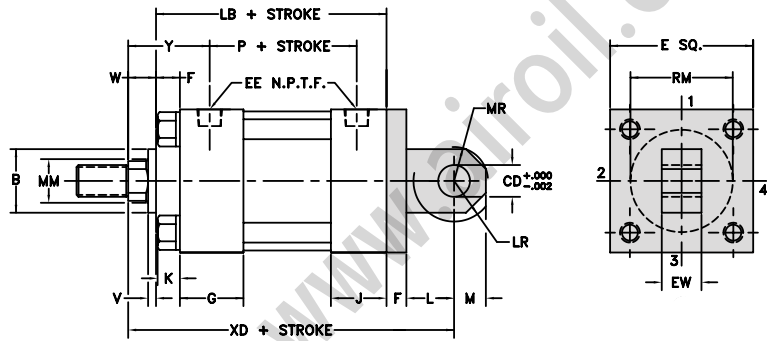

† HEAD END PORTS SHALLOW TAPPED

Ω FIXED CUSHIONS FURNISHED AT THE HEAD END IN THESE SIZES

Δ (4) SPANNER HOLES USED INSTEAD OF FLATS ON 4" DIA. AND LARGER RODS

§ THESE CYLINDERS HAVE FULL PLATE RETAINERS. USE "E" DIMENSION INSTEAD OF "RM" - SEE PAGE 42

‡ B DIMENSION TOLERANCE -.001/ -.003

* MAX WIDTH OF MATING PART

⊕ EYE DESIGNED TO FIT YATES STD CLEVIS BRACKET

STANDARD ROD ENDS

#2 STD MALE NFPA-SM

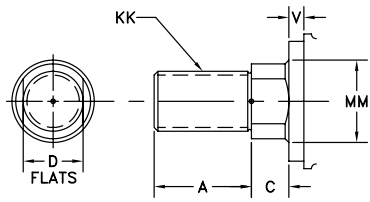

#4 STD FEMALE NFPA-SF

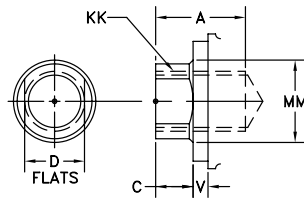

#1 MALE NFPA-IM

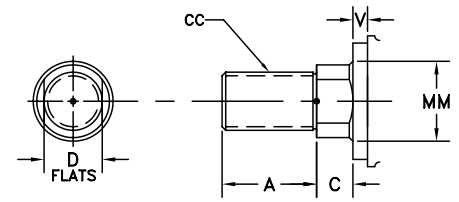

BORE	SAE															ADD STROKE	
	E	EE	OPT	F	G	J	K	CB*	CD	CW	EW	L	LR	M	MR	LB	P
1 1/2	2	3/8	6	3/8	1 1/2	1	1/4	3/4	1/2	1/2	3/4	3/4	9/16	1/2	9/16	4	2 3/16
2	2 1/2	3/8	6	3/8	1 1/2	1	5/16	3/4	1/2	1/2	3/4	3/4	9/16	1/2	9/16	4	2 3/16
2 1/2	3	3/8	6	3/8	1 1/2	1	5/16	3/4	1/2	1/2	3/4	3/4	9/16	1/2	9/16	4 1/8	2 5/16
3 1/4	3 3/4	1/2	10	5/8	1 3/4	1 1/4	3/8	1 1/4	3/4	5/8	1 1/4	1 1/4	1 1/16	3/4	7/8	4 7/8	2 5/8
4	4 1/2	1/2	10	5/8	1 3/4	1 1/4	3/8	1 1/4	3/4	5/8	1 1/4	1 1/4	1 1/16	3/4	7/8	4 7/8	2 5/8
5	5 1/2	1/2	10	5/8	1 3/4	1 1/4	7/16	1 1/4	3/4	5/8	1 1/4	1 1/4	1 1/16	3/4	7/8	5 1/8	2 7/8
6	6 1/2	3/4	12	3/4	2	1 1/2	7/16	1 1/2	1	3/4	1 1/2	1 1/2	1 5/16	1	1 1/8	5 3/4	3 1/8

BORE	ROD DIA. MM	THREAD		ROD EXTENSIONS AND PILOT DIMENSIONS								ADD STROKE XD
		KK	CC	A	B±	C	D	V	W	Y	RM	
1 1/2	5/8	7/16-20	1/2-20	3/4	1 1/8	3/8	1/2	1/4	5/8	1 31/32	§	5 3/4
	1†Ω	3/4-16	7/8-14	1 1/8	1 1/2	1/2	7/8	1/2	1	2 11/32	§	6 1/8
2	5/8	7/16-20	1/2-20	3/4	1 1/8	3/8	1/2	1/4	5/8	1 31/32	§	5 3/4
	1	3/4-16	7/8-14	1 1/8	1 1/2	1/2	7/8	1/2	1	2 11/32	§	6 1/8
	1 3/8†Ω	1-14	1 1/4-12	1 5/8	2	5/8	1 1/8	5/8	1 1/4	2 19/32	§	6 3/8
2 1/2	5/8	7/16-20	1/2-20	3/4	1 1/8	3/8	1/2	1/4	5/8	1 31/32	2 3/8	5 7/8
	1	3/4-16	7/8-14	1 1/8	1 1/2	1/2	7/8	1/2	1	2 11/32	2 5/8	6 1/4
	1 3/8	1-14	1 1/4-12	1 5/8	2	5/8	1 1/8	5/8	1 1/4	2 19/32	§	6 1/2
	1 3/4†Ω	1 1/4-12	1 1/2-12	2	2 3/8	3/4	1 1/2	3/4	1 1/2	2 27/32	§	6 3/4
3 1/4	1	3/4-16	7/8-14	1 1/8	1 1/2	1/2	7/8	1/4	3/4	2 7/16	2 5/8	7 1/2
	1 3/8	1-14	1 1/4-12	1 5/8	2	5/8	1 1/8	3/8	1	2 11/16	3 7/32	7 3/4
	1 3/4	1 1/4-12	1 1/2-12	2	2 3/8	3/4	1 1/2	1/2	1 1/4	2 15/16	§	8
	2†	1 1/2-12	1 3/4-12	2 1/4	2 5/8	7/8	1 3/4	1/2	1 3/8	3 1/16	§	8 1/8
4	1	3/4-16	7/8-14	1 1/8	1 1/2	1/2	7/8	1/4	3/4	2 7/16	2 5/8	7 1/2
	1 3/8	1-14	1 1/4-12	1 5/8	2	5/8	1 1/8	3/8	1	2 11/16	3 7/32	7 3/4
	1 3/4	1 1/4-12	1 1/2-12	2	2 3/8	3/4	1 1/2	1/2	1 1/4	2 15/16	3 7/8	8
	2	1 1/2-12	1 3/4-12	2 1/4	2 5/8	7/8	1 3/4	1/2	1 3/8	3 1/16	4	8 1/8
	2 1/2†	1 7/8-12	2 1/4-12	3	3 1/8	1	2 1/8	5/8	1 5/8	3 5/16	§	8 3/8
5	1	3/4-16	7/8-14	1 1/8	1 1/2	1/2	7/8	1/4	3/4	2 7/16	2 5/8	7 3/4
	1 3/8	1-14	1 1/4-12	1 5/8	2	5/8	1 1/8	3/8	1	2 11/16	3 7/32	8
	1 3/4	1 1/4-12	1 1/2-12	2	2 3/8	3/4	1 1/2	1/2	1 1/4	2 15/16	3 7/8	8 1/4
	2	1 1/2-12	1 3/4-12	2 1/4	2 5/8	7/8	1 3/4	1/2	1 3/8	3 1/16	4	8 3/8
	2 1/2	1 7/8-12	2 1/4-12	3	3 1/8	1	2 1/8	5/8	1 5/8	3 5/16	4 7/16	8 5/8
	3	2 1/4-12	2 3/4-12	3 1/2	3 3/4	1	2 5/8	5/8	1 5/8	3 5/16	§	8 5/8
6	3 1/2†	2 1/2-12	3 1/4-12	3 1/2	4 1/4	1	3	5/8	1 5/8	3 5/16	§	8 5/8
	1 3/8	1-14	1 1/4-12	1 5/8	2	5/8	1 1/8	1/4	7/8	2 13/16	3 7/32	8 7/8
	1 3/4	1 1/4-12	1 1/2-12	2	2 3/8	3/4	1 1/2	3/8	1 1/8	3 1/16	3 7/8	9 1/8
	2	1 1/2-12	1 3/4-12	2 1/4	2 5/8	7/8	1 3/4	3/8	1 1/4	3 3/16	4	9 1/4
	2 1/2	1 7/8-12	2 1/4-12	3	3 1/8	1	2 1/8	1/2	1 1/2	3 7/16	4 7/16	9 1/2
	3	2 1/4-12	2 3/4-12	3 1/2	3 3/4	1	2 5/8	1/2	1 1/2	3 7/16	5 1/4	9 1/2
	3 1/2	2 1/2-12	3 1/4-12	3 1/2	4 1/4	1	3	1/2	1 1/2	3 7/16	5 5/8	9 1/2
4	3-12	3 3/4-12	4	4 3/4	1	Δ	1/2	1 1/2	3 7/16	§	9 1/2	



1 1/2 THRU 6 BORE • SERIES A4/L4/H4

INTERMEDIATE FIXED TRUNNION MOUNT

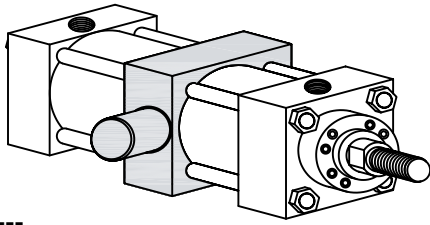

“T”
YATES STYLE T
NFPA-MT4

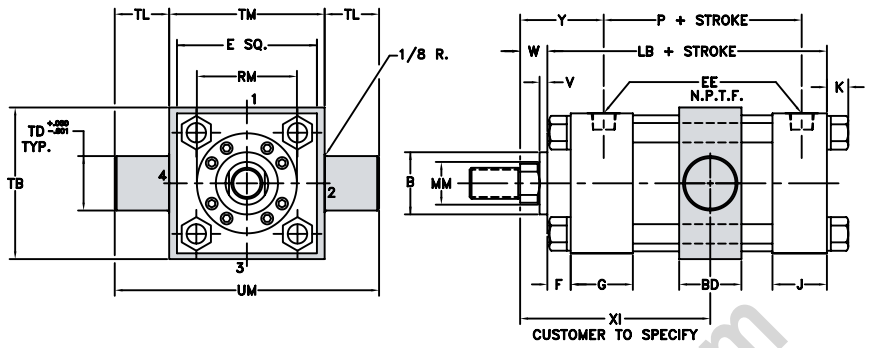

HEAD TRUNNION MOUNT

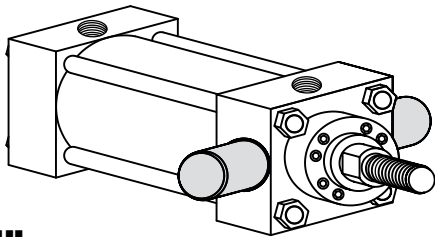

“U”
YATES STYLE U
NFPA-MT1

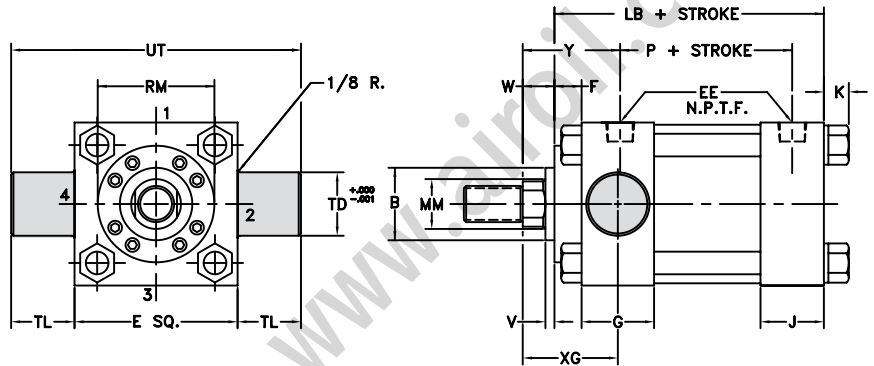

CAP TRUNNION MOUNT

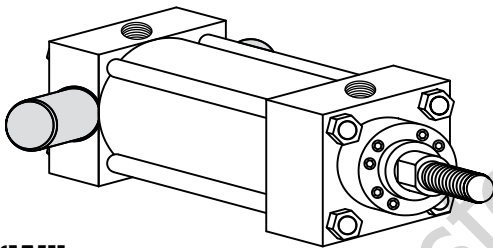

“W”
YATES STYLE W
NFPA-MT2

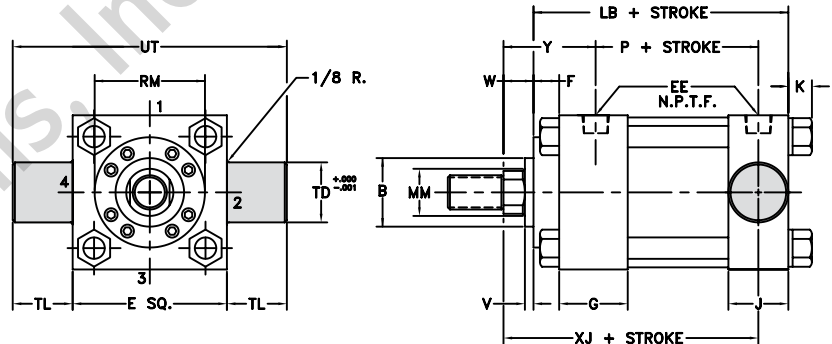

STANDARD ROD ENDS

#2 STD MALE
NFPA-SM

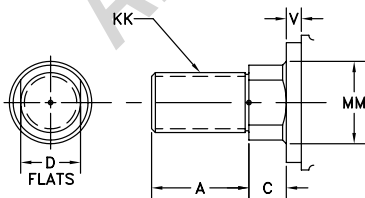

#4 STD FEMALE
NFPA-SF

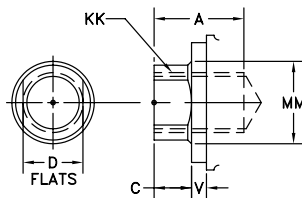

#1 MALE
NFPA-IM

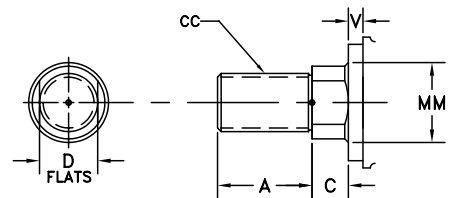

BORE	SAE														XI	ADD STROKE	
	E	EE	OPT	F	G	J	K	TD	TL	UT	TB	TM	UM	BD		LB	P
1 1/2	2	3/8	6	3/8	1 1/2	1	1/4	1	1	4	2 1/2	2 1/2	4 1/2	1 1/4	SPECIFY	4	2 3/16
2	2 1/2	3/8	6	3/8	1 1/2	1	5/16	1	1	4 1/2	3	3	5	1 1/2		4	2 3/16
2 1/2	3	3/8	6	3/8	1 1/2	1	5/16	1	1	5	3 1/2	3 1/2	5 1/2	1 1/2		4 1/8	2 5/16
3 1/4	3 3/4	1/2	10	5/8	1 3/4	1 1/4	3/8	1	1	5 3/4	4 1/4	4 1/2	6 1/2	2		4 7/8	2 5/8
4	4 1/2	1/2	10	5/8	1 3/4	1 1/4	3/8	1	1	6 1/2	5	5 1/4	7 1/4	2		4 7/8	2 5/8
5	5 1/2	1/2	10	5/8	1 3/4	1 1/4	7/16	1	1	7 1/2	6	6 1/4	8 1/4	2		5 1/8	2 7/8
6	6 1/2	3/4	12	3/4	2	1 1/2	7/16	1 3/8	1 3/8	9 1/4	7	7 5/8	10 3/8	2 1/2		5 3/4	3 1/8
8	8 1/2	3/4	12	3/4	2	1 1/2	9/16	1 3/8	1 3/8	11 1/4	9 1/2	9 3/4	12 1/2	2 1/2		5 7/8	3 1/4

BORE	ROD DIA.	THREAD		ROD EXTENSIONS AND PILOT DIMENSIONS										ADD STROKE	
	MM	KK	CC	A	B ‡	C	D	V	W	Y	RM	XG	XJ		
1 1/2	5/8	7/16-20	1/2-20	3/4	1 1/8	3/8	1/2	1/4	5/8	1 31/32	§	1 3/4	4 1/8		
	1†Ω	3/4-16	7/8-14	1 1/8	1 1/2	1/2	7/8	1/2	1	2 11/32	§	2 1/8	4 1/2		
2	5/8	7/16-20	1/2-20	3/4	1 1/8	3/8	1/2	1/4	5/8	1 31/32	§	1 3/4	4 1/8		
	1	3/4-16	7/8-14	1 1/8	1 1/2	1/2	7/8	1/2	1	2 11/32	§	2 1/8	4 1/2		
2 1/2	1 3/8†Ω	1-14	1 1/4-12	1 5/8	2	5/8	1 1/8	5/8	1 1/4	2 19/32	§	2 3/8	4 3/4		
	5/8	7/16-20	1/2-20	3/4	1 1/8	3/8	1/2	1/4	5/8	1 31/32	2 3/8	1 3/4	4 1/4		
3 1/4	1	3/4-16	7/8-14	1 1/8	1 1/2	1/2	7/8	1/4	3/4	2 7/16	2 5/8	2 1/4	5		
	1 3/8	1-14	1 1/4-12	1 5/8	2	5/8	1 1/8	3/8	1	2 11/16	3 7/32	2 1/2	5 1/4		
4	1 3/4	1 1/4-12	1 1/2-12	2	2 3/8	3/4	1 1/2	1/2	1 1/4	2 15/16	§	2 3/4	5 1/2		
	2†	1 1/2-12	1 3/4-12	2 1/4	2 5/8	7/8	1 3/4	1/2	1 3/8	3 1/16	§	2 7/8	5 5/8		
5	1	3/4-16	7/8-14	1 1/8	1 1/2	1/2	7/8	1/4	3/4	2 7/16	2 5/8	2 1/4	5 1/4		
	1 3/8	1-14	1 1/4-12	1 5/8	2	5/8	1 1/8	3/8	1	2 11/16	3 7/32	2 1/2	5 1/2		
6	1 3/4	1 1/4-12	1 1/2-12	2	2 3/8	3/4	1 1/2	1/2	1 1/4	2 15/16	3 7/8	2 3/4	5 3/4		
	2	1 1/2-12	1 3/4-12	2 1/4	2 5/8	7/8	1 3/4	1/2	1 3/8	3 1/16	4	2 7/8	5 7/8		
8	1 3/8	1-14	1 1/4-12	1 5/8	2	5/8	1 1/8	1/4	7/8	2 13/16	3 7/32	2 5/8	6		
	1 3/4	1 1/4-12	1 1/2-12	2	2 3/8	3/4	1 1/2	3/8	1 1/8	3 1/16	3 7/8	2 7/8	6 1/4		
2 1/2	2	1 1/2-12	1 3/4-12	2 1/4	2 5/8	7/8	1 3/4	3/8	1 1/4	3 3/16	4	3	6 3/8		
	2 1/2	1 7/8-12	2 1/4-12	3	3 1/8	1	2 1/8	1/2	1 1/2	3 7/16	4 7/16	3 1/4	6 1/2		
3 1/2	3	2 1/4-12	2 3/4-12	3 1/2	3 3/4	1	2 5/8	1/2	1 1/2	3 7/16	5 1/4	3 1/4	6 1/2		
	3 1/2†	2 1/2-12	3 1/4-12	3 1/2	4 1/4	1	3	5/8	1 5/8	3 5/16	§	3 1/8	6 1/8		
4	1 3/8	1-14	1 1/4-12	1 5/8	2	5/8	1 1/8	1/4	7/8	2 13/16	3 7/32	2 5/8	5 7/8		
	1 3/4	1 1/4-12	1 1/2-12	2	2 3/8	3/4	1 1/2	3/8	1 1/8	3 1/16	3 7/8	2 7/8	6 1/8		
5	2	1 1/2-12	1 3/4-12	2 1/4	2 5/8	7/8	1 3/4	3/8	1 1/4	3 3/16	4	3	6 1/4		
	2 1/2	1 7/8-12	2 1/4-12	3	3 1/8	1	2 1/8	1/2	1 1/2	3 7/16	4 7/16	3 1/4	6 1/2		
6	3	2 1/4-12	2 3/4-12	3 1/2	3 3/4	1	2 5/8	1/2	1 1/2	3 7/16	5 1/4	3 1/4	6 1/2		
	3 1/2	2 1/2-12	3 1/4-12	3 1/2	4 1/4	1	3	1/2	1 1/2	3 7/16	5 5/8	3 1/4	6 1/2		
7	4	3-12	3 3/4-12	4	4 3/4	1	Δ	1/2	1 1/2	3 7/16	§	3 1/4	6 1/2		
	4 1/2	3-12	3 3/4-12	4 1/2	5 1/4	1	Δ	1/2	1 1/2	3 7/16	7 1/8	3 1/4	6 5/8		
8	5	3 1/2-12	4 3/4-12	5	5 3/4	1	Δ	1/2	1 1/2	3 7/16	7 5/8	3 1/4	6 5/8		

† HEAD END PORTS SHALLOW TAPPED
Ω FIXED CUSHIONS FURNISHED AT THE HEAD END IN THESE SIZES
Δ (4) SPANNER HOLES USED INSTEAD OF FLATS ON 4" DIA. AND LARGER RODS
§ THESE CYLINDERS HAVE FULL PLATE RETAINERS. USE "E" DIMENSION INSTEAD OF "RM" - SEE PAGE 42
‡ B DIMENSION TOLERANCE -.001/-.003



INTERMEDIATE FIXED TRUNNION MOUNT

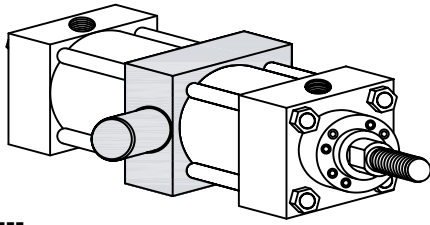

“T”
YATES STYLE T
NFPA-MT4

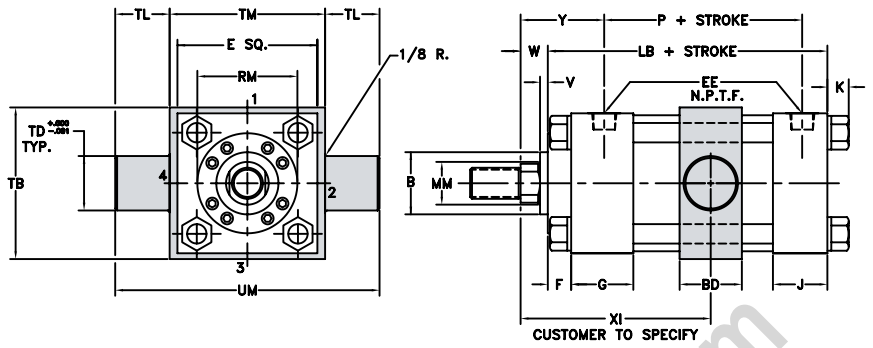

HEAD TRUNNION MOUNT

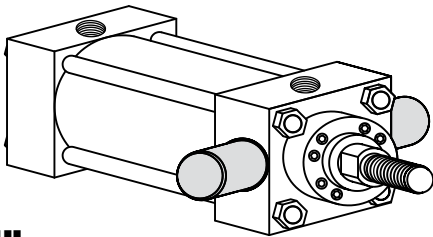

“U”
YATES STYLE U
NFPA-MT1

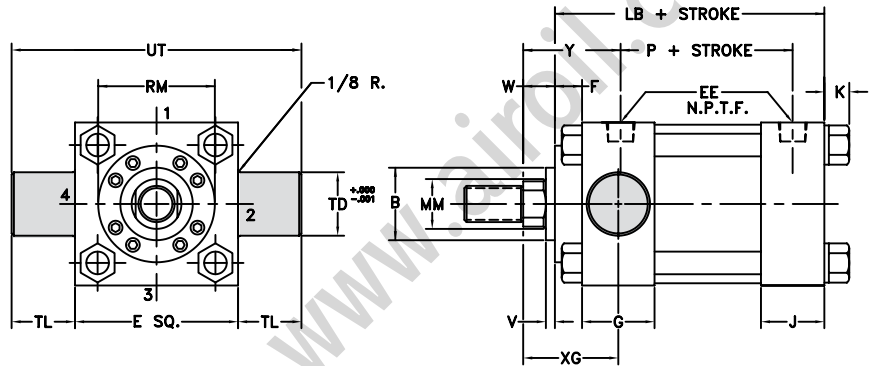

CAP TRUNNION MOUNT

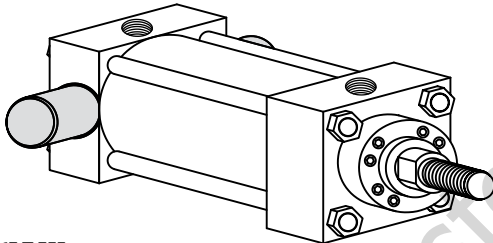

“W”
YATES STYLE W
NFPA-MT2

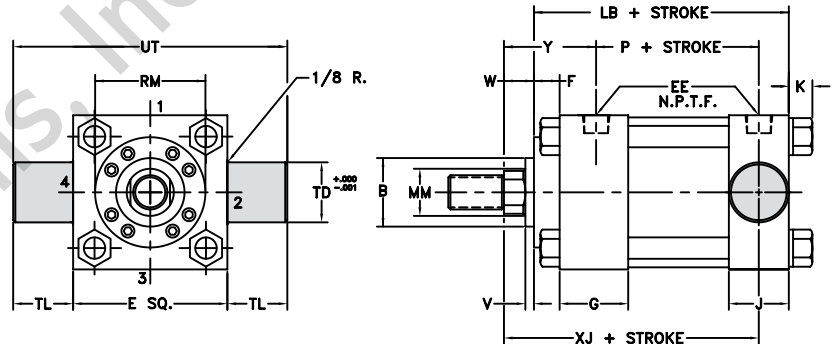

STANDARD ROD ENDS

#2 STD MALE
NFPA-SM

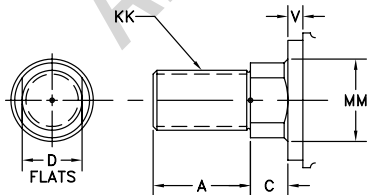

#4 STD FEMALE
NFPA-SF

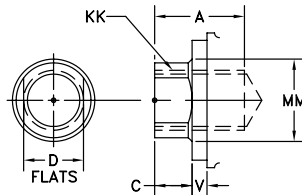

#1 MALE
NFPA-IM

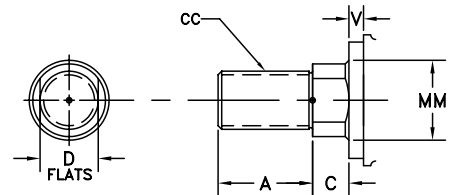

BORE	SAE														XI	ADD STROKE		
	E	EE	OPT	F	G	J	K	TD	TL	UT	TB	TM	UM	BD		LB	P	
10	10 5/8	1	16	3/4	2 1/4	2	11/16	1 3/4	1 3/4	14 1/8	11 3/4	12	15 1/2	3	SPECIFY	7 1/8	4 1/8	
12	12 3/4	1	16	3/4	2 1/4	2	11/16	1 3/4	1 3/4	16 1/4	13 3/4	14	17 1/2	3		7 5/8	4 5/8	
14	14 3/4	1 1/4	20	3/4	2 3/4	2 1/4	13/16	2	2	18 3/4	16	16 1/4	20 1/4	3 1/2		8 7/8	5 1/2	
16	17 1/2	1 1/2	24	3/4	2 15/16	2 15/16	15/16	2 3/4	2 3/4	23	NA	NA	NA	NA		NA	10	6 1/2
18	19 1/2	1 1/2	24	7/8	3 7/16	3 7/16	1	3	3	25 1/2	NA	NA	NA	NA		NA	11 1/8	6 1/2
20	21 3/4	2	32	7/8	3 15/16	3 15/16	1 1/8	3 1/2	3 1/2	28 3/4	NA	NA	NA	NA	NA	12 5/8	7 3/8	

BORE	ROD DIA. MM	THREAD		ROD EXTENSIONS AND PILOT DIMENSIONS									ADD STROKE XJ
		KK	CC	A	B ±	C	D	V	W	Y	RM	XG	
10	1 3/4	1 1/4-12	1 1/2-12	2	2 3/8	3/4	1 1/2	3/8	1 1/8	3 1/8	3 7/8	3	7 1/4
	2	1 1/2-12	1 3/4-12	2 1/4	2 5/8	7/8	1 3/4	3/8	1 1/4	3 1/4	4	3 1/8	7 3/8
	2 1/2	1 7/8-12	2 1/4-12	3	3 1/8	1	2 1/8	1/2	1 1/2	3 1/2	4 7/16	3 3/8	7 5/8
	3	2 1/4-12	2 3/4-12	3 1/2	3 3/4	1	2 5/8	1/2	1 1/2	3 1/2	5 1/4	3 3/8	7 5/8
	3 1/2	2 1/2-12	3 1/4-12	3 1/2	4 1/4	1	3	1/2	1 1/2	3 1/2	5 5/8	3 3/8	7 5/8
	4	3-12	3 3/4-12	4	4 3/4	1	Δ	1/2	1 1/2	3 1/2	6 7/16	3 3/8	7 5/8
	4 1/2	3 1/4-12	4 1/4-12	4 1/2	5 1/4	1	Δ	1/2	1 1/2	3 1/2	7 1/8	3 3/8	7 5/8
	5	3 1/2-12	4 3/4-12	5	5 3/4	1	Δ	1/2	1 1/2	3 1/2	7 5/8	3 3/8	7 5/8
5 1/2	4-12	5 1/4-12	5 1/2	6 1/4	1	Δ	1/2	1 1/2	3 1/2	8 3/8	3 3/8	7 5/8	
12	2	1 1/2-12	1 3/4-12	2 1/4	2 5/8	7/8	1 3/4	3/8	1 1/4	3 1/4	4	3 1/8	7 7/8
	2 1/2	1 7/8-12	2 1/4-12	3	3 1/8	1	2 1/8	1/2	1 1/2	3 1/2	4 7/16	3 3/8	8 1/8
	3	2 1/4-12	2 3/4-12	3 1/2	3 3/4	1	2 5/8	1/2	1 1/2	3 1/2	5 1/4	3 3/8	8 1/8
	3 1/2	2 1/2-12	3 1/4-12	3 1/2	4 1/4	1	3	1/2	1 1/2	3 1/2	5 5/8	3 3/8	8 1/8
	4	3-12	3 3/4-12	4	4 3/4	1	Δ	1/2	1 1/2	3 1/2	6 7/16	3 3/8	8 1/8
	4 1/2	3 1/4-12	4 1/4-12	4 1/2	5 1/4	1	Δ	1/2	1 1/2	3 1/2	7 1/8	3 3/8	8 1/8
	5	3 1/2-12	4 3/4-12	5	5 3/4	1	Δ	1/2	1 1/2	3 1/2	7 5/8	3 3/8	8 1/8
	5 1/2	4-12	5 1/4-12	5 1/2	6 1/4	1	Δ	1/2	1 1/2	3 1/2	8 3/8	3 3/8	8 1/8
14	2 1/2	1 7/8-12	2 1/4-12	3	3 1/8	1	2 1/8	1/2	1 1/2	3 13/16	4 7/16	3 5/8	9 1/4
	3	2 1/4-12	2 3/4-12	3 1/2	3 3/4	1	2 5/8	1/2	1 1/2	3 13/16	5 1/4	3 5/8	9 1/4
	3 1/2	2 1/2-12	3 1/4-12	3 1/2	4 1/4	1	3	1/2	1 1/2	3 13/16	5 5/8	3 5/8	9 1/4
	4	3-12	3 3/4-12	4	4 3/4	1	Δ	1/2	1 1/2	3 13/16	6 7/16	3 5/8	9 1/4
	4 1/2	3 1/4-12	4 1/4-12	4 1/2	5 1/4	1	Δ	1/2	1 1/2	3 13/16	7 1/8	3 5/8	9 1/4
	5	3 1/2-12	4 3/4-12	5	5 3/4	1	Δ	1/2	1 1/2	3 13/16	7 5/8	3 5/8	9 1/4
	5 1/2	4-12	5 1/4-12	5 1/2	6 1/4	1	Δ	1/2	1 1/2	3 13/16	8 3/8	3 5/8	9 1/4
	16	3 1/2	2 1/2-12	3 1/4-12	3 1/2	4 1/4	1	3	1/2	1 1/2	3 5/8	5 5/8	3 11/16
4	3-12	3 3/4-12	4	4 3/4	1	Δ	1/2	1 1/2	3 5/8	6 7/16	3 11/16	10 1/16	
4 1/2	3 1/4-12	4 1/4-12	4 1/2	5 1/4	1	Δ	1/2	1 1/2	3 5/8	7 1/8	3 11/16	10 1/16	
5	3 1/2-12	4 3/4-12	5	5 3/4	1	Δ	1/2	1 1/2	3 5/8	7 5/8	3 11/16	10 1/16	
5 1/2	4-12	5 1/4-12	5 1/2	6 1/4	1	Δ	1/2	1 1/2	3 5/8	8 3/8	3 11/16	10 1/16	
18	4	3-12	3 3/4-12	4	4 3/4	1	Δ	3/8	1 3/8	4 1/8	6 7/16	3 15/16	10 13/16
	4 1/2	3 1/4-12	4 1/4-12	4 1/2	5 1/4	1	Δ	3/8	1 3/8	4 1/8	7 1/8	3 15/16	10 13/16
	5	3 1/2-12	4 3/4-12	5	5 3/4	1	Δ	3/8	1 3/8	4 1/8	7 5/8	3 15/16	10 13/16
	5 1/2	4-12	5 1/4-12	5 1/2	6 1/4	1	Δ	3/8	1 3/8	4 1/8	8 3/8	3 15/16	10 13/16
20	4	3-12	3 3/4-12	4	4 3/4	1	Δ	3/8	1 3/8	4 7/16	6 7/16	4 3/16	12 1/16
	4 1/2	3 1/4-12	4 1/4-12	4 1/2	5 1/4	1	Δ	3/8	1 3/8	4 7/16	7 1/8	4 3/16	12 1/16
	5	3 1/2-12	4 3/4-12	5	5 3/4	1	Δ	3/8	1 3/8	4 7/16	7 5/8	4 3/16	12 1/16
	5 1/2	4-12	5 1/4-12	5 1/2	6 1/4	1	Δ	3/8	1 3/8	4 7/16	8 3/8	4 3/16	12 1/16

- † HEAD END PORTS SHALLOW TAPPED
- Ω FIXED CUSHIONS FURNISHED AT THE HEAD END IN THESE SIZES
- Δ (4) SPANNER HOLES USED INSTEAD OF FLATS ON 4" DIA. AND LARGER RODS
- § THESE CYLINDERS HAVE FULL PLATE RETAINERS. USE "E" DIMENSION INSTEAD OF "RM" - SEE PAGE 42
- ‡ B DIMENSION TOLERANCE -.001/-.003



HEAD RECTANGULAR FLANGE MOUNT

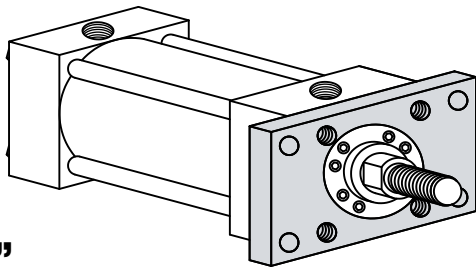

“F”

YATES STYLE **F**
NFPA-MF1

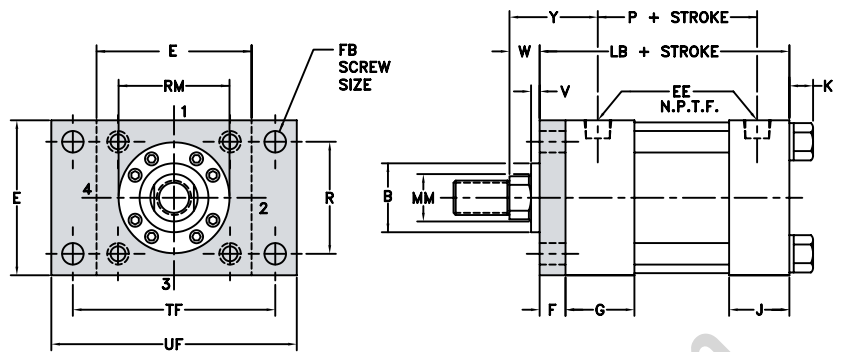

HEAD SQUARE FLANGE MOUNT

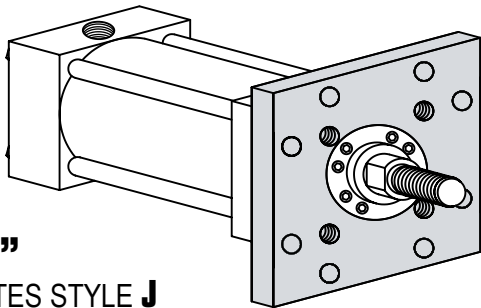

“J”

YATES STYLE **J**
NFPA-MF5

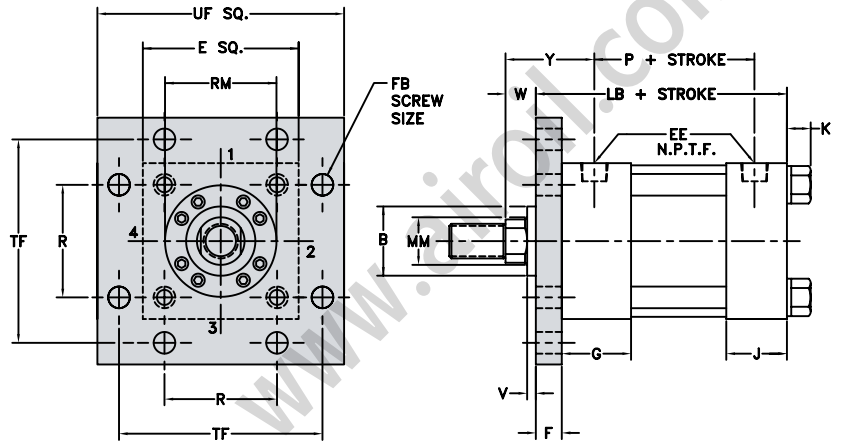

CAP RECTANGULAR FLANGE MOUNT

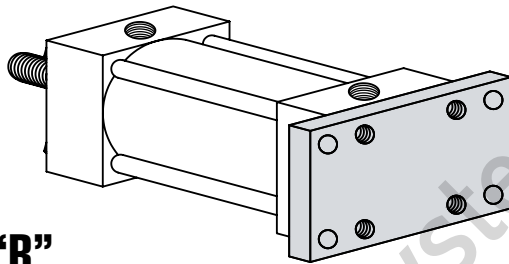

“R”

YATES STYLE **R**
NFPA-MF2

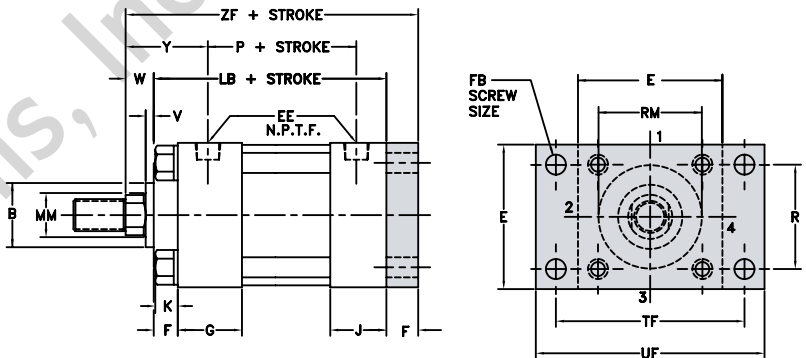

CAP SQUARE FLANGE MOUNT

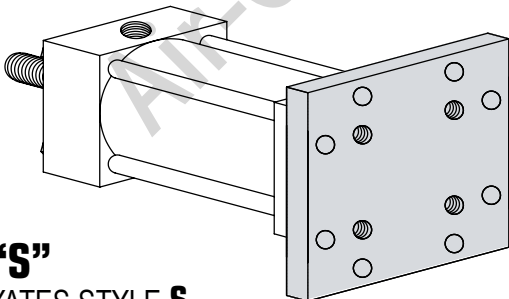

“S”

YATES STYLE **S**
NFPA-MF6

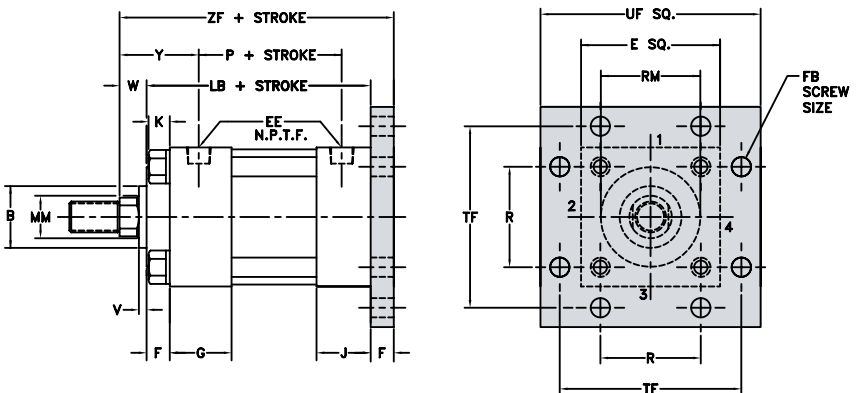

STANDARD ROD ENDS

#2 STD MALE NFPA-SM

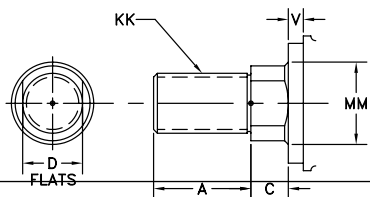

#4 STD FEMALE NFPA-SF

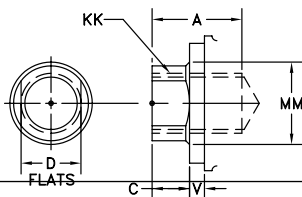

#1 MALE NFPA-IM

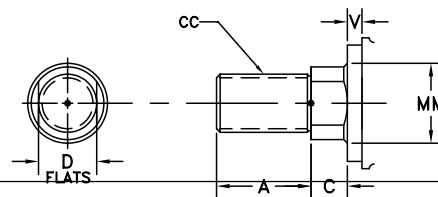

BORE	SAE											ADD STROKE	
	E	EE	OPT	F	G	J	K	FB	R	TF	UF	LB	P
1 1/2	2	3/8	6	3/8	1 1/2	1	1/4	1/4	1.43	2 3/4	3 3/8	4	2 3/16
2	2 1/2	3/8	6	3/8	1 1/2	1	5/16	5/16	1.84	3 3/8	4 1/8	4	2 3/16
2 1/2	3	3/8	6	3/8	1 1/2	1	5/16	5/16	2.19	3 7/8	4 5/8	4 1/8	2 5/16
3 1/4	3 3/4	1/2	10	5/8	1 3/4	1 1/4	3/8	3/8	2.76	4 11/16	5 1/2	4 7/8	2 5/8
4	4 1/2	1/2	10	5/8	1 3/4	1 1/4	3/8	3/8	3.32	5 7/16	6 1/4	4 7/8	2 5/8
5	5 1/2	1/2	10	5/8	1 3/4	1 1/4	7/16	1/2	4.10	6 5/8	7 5/8	5 1/8	2 7/8
6	6 1/2	3/4	12	3/4	2	1 1/2	7/16	1/2	4.88	7 5/8	8 5/8	5 3/4	3 1/8

BORE	ROD DIA. MM	THREAD		ROD EXTENSIONS AND PILOT DIMENSIONS								ADD STROKE	F MOUNT MAX PSI
		KK	CC	A	B±	C	D	V	W	Y	RM	ZF	PUSH
1 1/2	5/8	7/16-20	1/2-20	3/4	1 1/8	3/8	1/2	1/4	5/8	1 31/32	§	5	650
	1†Ω	3/4-16	7/8-14	1 1/8	1 1/2	1/2	7/8	1/2	1	2 11/32	§	5 3/8	375
2	5/8	7/16-20	1/2-20	3/4	1 1/8	3/8	1/2	1/4	5/8	1 31/32	§	5	500
	1	3/4-16	7/8-14	1 1/8	1 1/2	1/2	7/8	1/2	1	2 11/32	§	5 3/8	350
	1 3/8†Ω	1-14	1 1/4-12	1 5/8	2	5/8	1 1/8	5/8	1 1/4	2 19/32	§	5 5/8	200
2 1/2	5/8	7/16-20	1/2-20	3/4	1 1/8	3/8	1/2	1/4	5/8	1 31/32	2 3/8	5 1/8	300
	1	3/4-16	7/8-14	1 1/8	1 1/2	1/2	7/8	1/2	1	2 11/32	2 5/8	5 1/2	300
	1 3/8	1-14	1 1/4-12	1 5/8	2	5/8	1 1/8	5/8	1 1/4	2 19/32	§	5 3/4	200
	1 3/4†Ω	1 1/4-12	1 1/2-12	2	2 3/8	3/4	1 1/2	3/4	1 1/2	2 27/32	§	6	150
3 1/4	1	3/4-16	7/8-14	1 1/8	1 1/2	1/2	7/8	1/4	3/4	2 7/16	2 5/8	6 1/4	650
	1 3/8	1-14	1 1/4-12	1 5/8	2	5/8	1 1/8	3/8	1	2 11/16	3 7/32	6 1/2	650
	1 3/4	1 1/4-12	1 1/2-12	2	2 3/8	3/4	1 1/2	1/2	1 1/4	2 15/16	§	6 3/4	400
	2†	1 1/2-12	1 3/4-12	2 1/4	2 5/8	7/8	1 3/4	1/2	1 3/8	3 1/16	§	6 7/8	350
	4	3/4-16	7/8-14	1 1/8	1 1/2	1/2	7/8	1/4	3/4	2 7/16	2 5/8	6 1/4	450
4	1 3/8	1-14	1 1/4-12	1 5/8	2	5/8	1 1/8	3/8	1	2 11/16	3 7/32	6 1/2	450
	1 3/4	1 1/4-12	1 1/2-12	2	2 3/8	3/4	1 1/2	1/2	1 1/4	2 15/16	3 7/8	6 3/4	325
	2	1 1/2-12	1 3/4-12	2 1/4	2 5/8	7/8	1 3/4	1/2	1 3/8	3 1/16	4	6 7/8	325
	2 1/2†	1 7/8-12	2 1/4-12	3	3 1/8	1	2 1/8	5/8	1 5/8	3 5/16	§	7 1/8	225
	5	3/4-16	7/8-14	1 1/8	1 1/2	1/2	7/8	1/4	3/4	2 7/16	2 5/8	6 1/2	300
	1 3/8	1-14	1 1/4-12	1 5/8	2	5/8	1 1/8	3/8	1	2 11/16	3 7/32	6 3/4	300
5	1 3/4	1 1/4-12	1 1/2-12	2	2 3/8	3/4	1 1/2	1/2	1 1/4	2 15/16	3 7/8	7	300
	2	1 1/2-12	1 3/4-12	2 1/4	2 5/8	7/8	1 3/4	1/2	1 3/8	3 1/16	4	7 1/8	225
	2 1/2	1 7/8-12	2 1/4-12	3	3 1/8	1	2 1/8	5/8	1 5/8	3 5/16	4 7/16	7 3/8	225
	3	2 1/4-12	2 3/4-12	3 1/2	3 3/4	1	2 5/8	5/8	1 5/8	3 5/16	§	7 3/8	175
	3 1/2†	2 1/2-12	3 1/4-12	3 1/2	4 1/4	1	3	5/8	1 5/8	3 5/16	§	7 3/8	125
	6	3/4-16	7/8-14	1 1/8	1 1/2	1/2	7/8	1/4	3/4	2 7/16	2 5/8	6 1/2	300
	1 3/8	1-14	1 1/4-12	1 5/8	2	5/8	1 1/8	3/8	1	2 11/16	3 7/32	6 3/4	300
6	1 3/4	1 1/4-12	1 1/2-12	2	2 3/8	3/4	1 1/2	3/8	1 1/8	3 1/16	3 7/8	7 5/8	350
	2	1 1/2-12	1 3/4-12	2 1/4	2 5/8	7/8	1 3/4	3/8	1 1/4	3 3/16	4	7 3/4	300
	2 1/2	1 7/8-12	2 1/4-12	3	3 1/8	1	2 1/8	1/2	1 1/2	3 7/16	4 7/16	8	300
	3	2 1/4-12	2 3/4-12	3 1/2	3 3/4	1	2 5/8	1/2	1 1/2	3 7/16	5 1/4	8	200
	3 1/2	2 1/2-12	3 1/4-12	3 1/2	4 1/4	1	3	1/2	1 1/2	3 7/16	5 5/8	8	200
	4	3-12	3 3/4-12	4	4 3/4	1	Δ	1/2	1 1/2	3 7/16	§	8	200

† HEAD END PORTS SHALLOW TAPPED
 Ω FIXED CUSHIONS FURNISHED AT THE HEAD END IN THESE SIZES
 Δ (4) SPANNER HOLES USED INSTEAD OF FLATS ON 4" DIA. AND LARGER RODS
 § THESE CYLINDERS HAVE FULL PLATE RETAINERS. USE "E" DIMENSION INSTEAD OF "RM" - SEE PAGE 42
 ‡ B DIMENSION TOLERANCE -.001/-.003



HEAD RECTANGULAR INTEGRAL FLANGE MOUNT

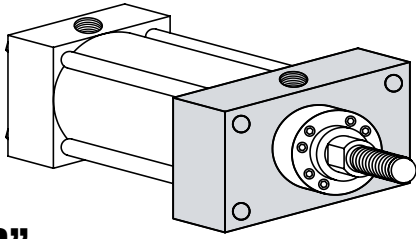

“G”
YATES STYLE **G**
NFPA-ME5

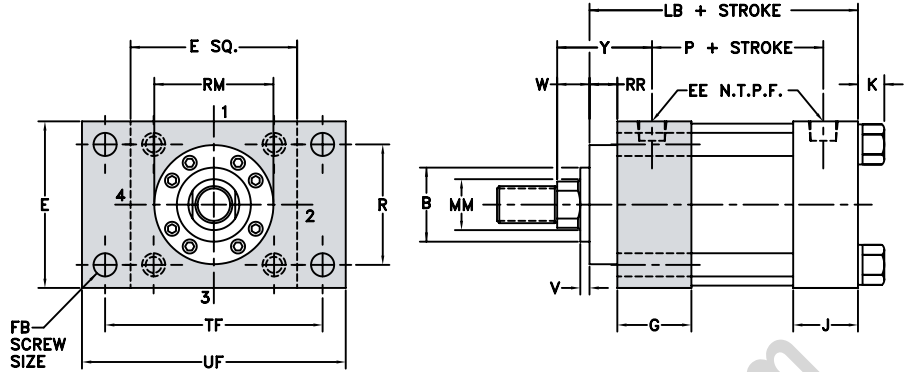

CAP RECTANGULAR INTEGRAL FLANGE MOUNT

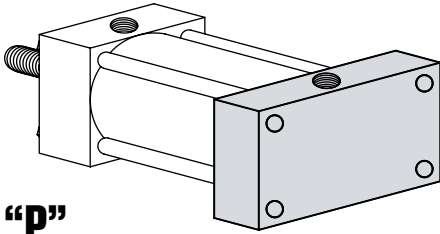

“P”
YATES STYLE **P**
NFPA-ME6

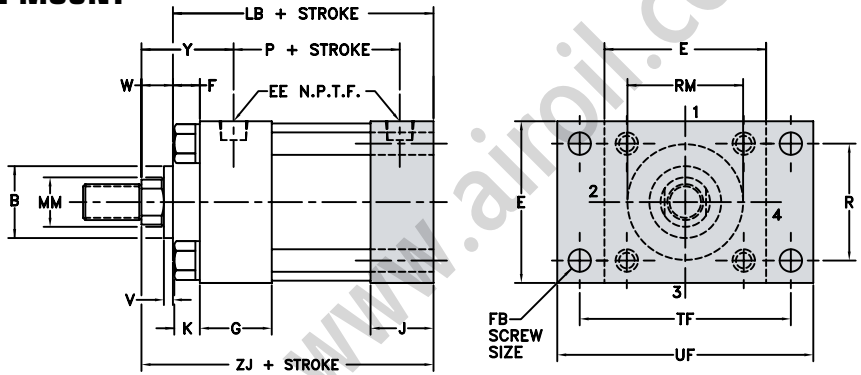

STANDARD ROD ENDS

#2 STD MALE
NFPA-SM

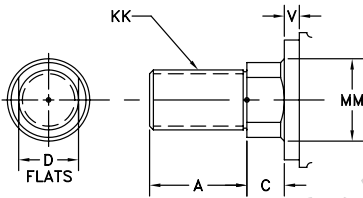

#4 STD FEMALE
NFPA-SF

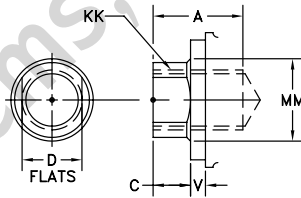

#1 MALE
NFPA-IM

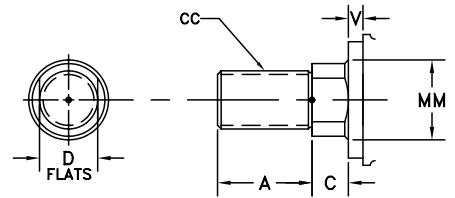

BORE	SAE											ADD STROKE	
	E	EE	OPT	F	G	J	K	FB	R	TF	UF	LB	P
1 1/2	2	3/8	6	3/8	1 1/2	1	1/4	1/4	1.43	2 3/4	3 3/8	4	2 3/16
2	2 1/2	3/8	6	3/8	1 1/2	1	5/16	5/16	1.84	3 3/8	4 1/8	4	2 3/16
2 1/2	3	3/8	6	3/8	1 1/2	1	5/16	5/16	2.19	3 7/8	4 5/8	4 1/8	2 5/16
3 1/4	3 3/4	1/2	10	5/8	1 3/4	1 1/4	3/8	3/8	2.76	4 11/16	5 1/2	4 7/8	2 5/8
4	4 1/2	1/2	10	5/8	1 3/4	1 1/4	3/8	3/8	3.32	5 7/16	6 1/4	4 7/8	2 5/8
5	5 1/2	1/2	10	5/8	1 3/4	1 1/4	7/16	1/2	4.10	6 5/8	7 5/8	5 1/8	2 7/8
6	6 1/2	3/4	12	3/4	2	1 1/2	7/16	1/2	4.88	7 5/8	8 5/8	5 3/4	3 1/8

BORE	ROD DIA.			ROD EXTENSIONS AND PILOT DIMENSIONS									ADD STROKE
	MM	KK	CC	A	B ‡	C	D	V	W	RR	RM	Y	
1 1/2	5/8	7/16-20	1/2-20	3/4	1 1/8	3/8	1/2	1/4	5/8	3/8	2 3/8	1 31/32	4 5/8
	1†Ω	3/4-16	7/8-14	1 1/8	1 1/2	1/2	7/8	1/2	1	5/8	§	2 11/32	5
2	5/8	7/16-20	1/2-20	3/4	1 1/8	3/8	1/2	1/4	5/8	3/8	2 3/8	1 31/32	4 5/8
	1	3/4-16	7/8-14	1 1/8	1 1/2	1/2	7/8	1/2	1	5/8	§	2 11/32	5
	1 3/8†Ω	1-14	1 1/4-12	1 5/8	2	5/8	1 1/8	5/8	1 1/4	5/8	§	2 19/32	5 1/4
2 1/2	5/8	7/16-20	1/2-20	3/4	1 1/8	3/8	1/2	1/4	5/8	3/8	2 3/8	1 31/32	4 3/4
	1	3/4-16	7/8-14	1 1/8	1 1/2	1/2	7/8	1/2	1	3/8	2 5/8	2 11/32	5 1/8
	1 3/8	1-14	1 1/4-12	1 5/8	2	5/8	1 1/8	5/8	1 1/4	5/8	§	2 19/32	5 3/8
3 1/4	1 3/4†Ω	1 1/4-12	1 1/2-12	2	2 3/8	3/4	1 1/2	3/4	1 1/2	5/8	§	2 27/32	5 5/8
	1	3/4-16	7/8-14	1 1/8	1 1/2	1/2	7/8	1/4	3/4	5/8	2 5/8	2 7/16	5 5/8
	1 3/8	1-14	1 1/4-12	1 5/8	2	5/8	1 1/8	3/8	1	5/8	3 7/32	2 11/16	5 7/8
	1 3/4	1 1/4-12	1 1/2-12	2	2 3/8	3/4	1 1/2	1/2	1 1/4	5/8	§	2 15/16	6 1/8
4	2†	1 1/2-12	1 3/4-12	2 1/4	2 5/8	7/8	1 3/4	1/2	1 3/8	5/8	§	3 1/16	6 1/4
	1	3/4-16	7/8-14	1 1/8	1 1/2	1/2	7/8	1/4	3/4	5/8	2 5/8	2 7/16	5 5/8
	1 3/8	1-14	1 1/4-12	1 5/8	2	5/8	1 1/8	3/8	1	5/8	3 7/32	2 11/16	5 7/8
	1 3/4	1 1/4-12	1 1/2-12	2	2 3/8	3/4	1 1/2	1/2	1 1/4	5/8	3 7/8	2 15/16	6 1/8
5	2	1 1/2-12	1 3/4-12	2 1/4	2 5/8	7/8	1 3/4	1/2	1 3/8	5/8	4	3 1/16	6 1/2
	2 1/2†	1 7/8-12	2 1/4-12	3	3 1/8	1	2 1/8	5/8	1 5/8	5/8	§	3 5/16	6 1/2
	1	3/4-16	7/8-14	1 1/8	1 1/2	1/2	7/8	1/4	3/4	5/8	2 5/8	2 7/16	5 7/8
	1 3/8	1-14	1 1/4-12	1 5/8	2	5/8	1 1/8	3/8	1	5/8	3 7/32	2 11/16	6 1/8
	1 3/4	1 1/4-12	1 1/2-12	2	2 3/8	3/4	1 1/2	1/2	1 1/4	5/8	3 7/8	2 15/16	6 3/8
	2	1 1/2-12	1 3/4-12	2 1/4	2 5/8	7/8	1 3/4	1/2	1 3/8	5/8	4	3 1/16	6 1/2
	2 1/2	1 7/8-12	2 1/4-12	3	3 1/8	1	2 1/8	5/8	1 5/8	5/8	4 7/16	3 5/16	6 3/4
6	3	2 1/4-12	2 3/4-12	3 1/2	3 3/4	1	2 5/8	5/8	1 5/8	3/4	§	3 5/16	6 3/4
	3 1/2†	2 1/2-12	3 1/4-12	3 1/2	4 1/4	1	3	5/8	1 5/8	5/8	§	3 5/16	6 3/4
	1 3/8	1-14	1 1/4-12	1 5/8	2	5/8	1 1/8	1/4	7/8	5/8	3 7/32	2 13/16	6 5/8
	1 3/4	1 1/4-12	1 1/2-12	2	2 3/8	3/4	1 1/2	3/8	1 1/8	5/8	3 7/8	3 1/16	6 7/8
	2	1 1/2-12	1 3/4-12	2 1/4	2 5/8	7/8	1 3/4	3/8	1 1/4	5/8	4	3 3/16	7
	2 1/2	1 7/8-12	2 1/4-12	3	3 1/8	1	2 1/8	1/2	1 1/2	5/8	4 7/16	3 7/16	7 1/4
	3	2 1/4-12	2 3/4-12	3 1/2	3 3/4	1	2 5/8	1/2	1 1/2	3/4	5 1/4	3 7/16	7 1/4
6	3 1/2	2 1/2-12	3 1/4-12	3 1/2	4 1/4	1	3	1/2	1 1/2	3/4	5 5/8	3 7/16	7 1/4
	4	3-12	3 3/4-12	4	4 3/4	1	Δ	1/2	1 1/2	5/8	§	3 7/16	7 1/4

† HEAD END PORTS SHALLOW TAPPED
Ω FIXED CUSHIONS FURNISHED AT THE HEAD END IN THESE SIZES
Δ (4) SPANNER HOLES USED INSTEAD OF FLATS ON 4" DIA. AND LARGER RODS
§ THESE CYLINDERS HAVE FULL PLATE RETAINERS. USE "E" DIMENSION INSTEAD OF "RM" - SEE PAGE 42
‡ B DIMENSION TOLERANCE -.001/-.003



HEAD SQUARE INTEGRAL FLANGE MOUNT

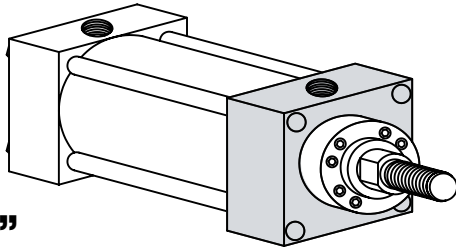

“X”
YATES STYLE X
NFPA-ME3

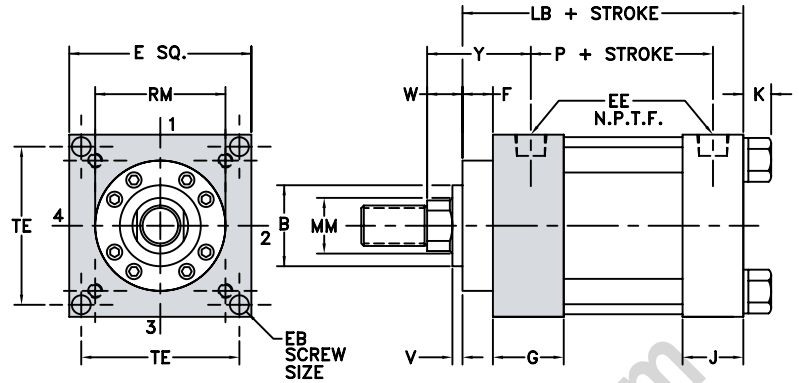

CAP SQUARE INTEGRAL FLANGE MOUNT

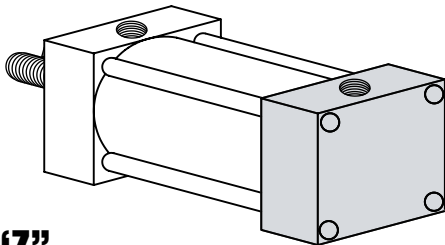

“Z”
YATES STYLE Z
NFPA-ME4

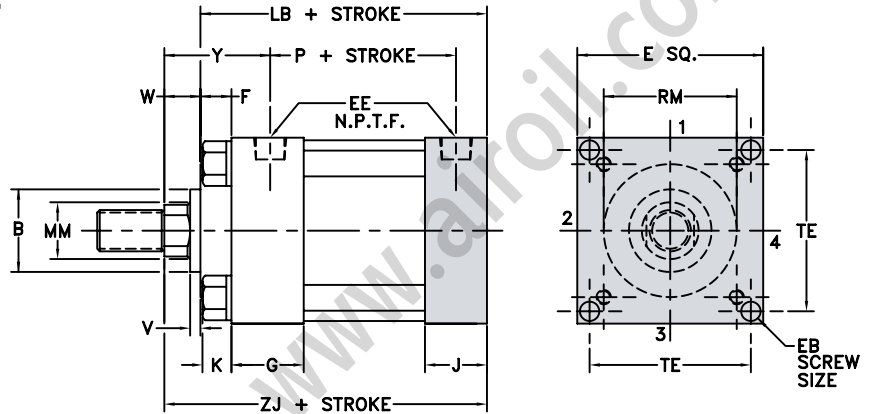

STANDARD ROD ENDS

#2 STD MALE
NFPA-SM

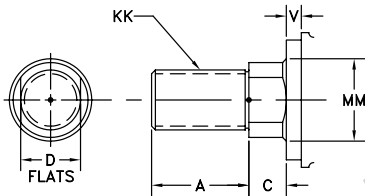

#4 STD FEMALE
NFPA-SF

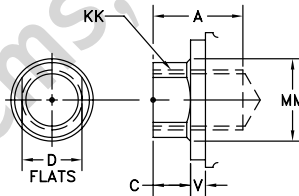

#1 MALE
NFPA-IM

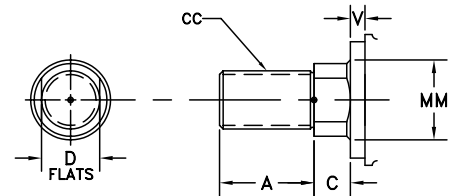

BORE	E	EE	SAE	F	G	J	K	EB	TE	ADD STROKE	
										LB	P
8	8 1/2	3/4	12	3/4	2	1 1/2	9/16	5/8	7.57	5 7/8	3 1/4

BORE	ROD DIA. MM	THREAD		ROD EXTENSIONS AND PILOT DIMENSIONS								ADD STROKE ZJ
		KK	CC	A	B ‡	C	D	V	W	Y	RM	
8	1 3/8	1-14	1 1/4-12	1 5/8	2	5/8	1 1/8	1/4	7/8	2 13/16	3 7/32	6 3/4
	1 3/4	1 1/4-12	1 1/2-12	2	2 3/8	3/4	1 1/2	3/8	1 1/8	3 1/16	3 7/8	7
	2	1 1/2-12	1 3/4-12	2 1/4	2 5/8	7/8	1 3/4	3/8	1 1/4	3 3/16	4	7 1/8
	2 1/2	1 7/8-12	2 1/4-12	3	3 1/8	1	2 1/8	1/2	1 1/2	3 7/16	4 7/16	7 3/8
	3	2 1/4-12	2 3/4-12	3 1/2	3 3/4	1	2 5/8	1/2	1 1/2	3 7/16	5 1/4	7 3/8
	3 1/2	2 1/2-12	3 1/4-12	3 1/2	4 1/4	1	3	1/2	1 1/2	3 7/16	5 5/8	7 3/8
	4	3-12	3 3/4-12	4	4 3/4	1	Δ	1/2	1 1/2	3 7/16	6 7/16	7 3/8
	4 1/2	3 1/4-12	4 1/4-12	4 1/2	5 1/4	1	Δ	1/2	1 1/2	3 7/16	7 1/8	7 3/8
5	3 1/2-12	4 3/4-12	5	5 3/4	1	Δ	1/2	1 1/2	3 7/16	7 5/8	7 3/8	

BORE	SAE									ADD STROKE	
	E	EE	OPT	F	G	J	K	EB	TE	LB	P
10	10 5/8	1	16	3/4	2 1/4	2	11/16	3/4	9.40	7 1/8	4 1/8
12	12 3/4	1	16	3/4	2 1/4	2	11/16	3/4	11.10	7 5/8	4 5/8
14	14 3/4	1 1/4	20	3/4	2 3/4	2 1/4	13/16	7/8	12.87	8 7/8	5 1/2
16	17 1/2	1 1/2	24	3/4	2 15/16	2 15/16	15/16	1 1/4	14.75	10	6 1/2
18	19 1/2	1 1/2	24	7/8	3 7/16	3 7/16	1	1 1/2	16.50	11 1/8	6 1/2
20	21 3/4	2	32	7/8	3 15/16	3 15/16	1 1/8	1 3/4	18.25	12 5/8	7 3/8

BORE	ROD DIA.	THREAD		ROD EXTENSIONS AND PILOT DIMENSIONS								ADD STROKE	
	MM	KK	CC	A	B±	C	D	V	W	Y	RM	ZJ	
10	1 3/4	1 1/4-12	1 1/2-12	2	2 3/8	3/4	1 1/2	3/8	1 1/8	3 1/8	3 7/8	8 1/4	
	2	1 1/2-12	1 3/4-12	2 1/4	2 5/8	7/8	1 3/4	3/8	1 1/4	3 1/4	4	8 3/8	
	2 1/2	1 7/8-12	2 1/4-12	3	3 1/8	1	2 1/8	1/2	1 1/2	3 1/2	4 7/16	8 5/8	
	3	2 1/4-12	2 3/4-12	3 1/2	3 3/4	1	2 5/8	1/2	1 1/2	3 1/2	5 1/4	8 5/8	
	3 1/2	2 1/2-12	3 1/4-12	3 1/2	4 1/4	1	3	1/2	1 1/2	3 1/2	5 5/8	8 5/8	
	4	3-12	3 3/4-12	4	4 3/4	1	Δ	1/2	1 1/2	3 1/2	6 7/16	8 5/8	
	4 1/2	3 1/4-12	4 1/4-12	4 1/2	5 1/4	1	Δ	1/2	1 1/2	3 1/2	7 1/8	8 5/8	
12	5	3 1/2-12	4 3/4-12	5	5 3/4	1	Δ	1/2	1 1/2	3 1/2	7 5/8	8 5/8	
	5 1/2	4-12	5 1/4-12	5 1/2	6 1/4	1	Δ	1/2	1 1/2	3 1/2	8 3/8	8 5/8	
	2	1 1/2-12	1 3/4-12	2 1/4	2 5/8	7/8	1 3/4	3/8	1 1/4	3 1/4	4	8 7/8	
	2 1/2	1 7/8-12	2 1/4-12	3	3 1/8	1	2 1/8	1/2	1 1/2	3 1/2	4 7/16	9 1/8	
	3	2 1/4-12	2 3/4-12	3 1/2	3 3/4	1	2 5/8	1/2	1 1/2	3 1/2	5 1/4	9 1/8	
	3 1/2	2 1/2-12	3 1/4-12	3 1/2	4 1/4	1	3	1/2	1 1/2	3 1/2	5 5/8	9 1/8	
	4	3-12	3 3/4-12	4	4 3/4	1	Δ	1/2	1 1/2	3 1/2	6 7/16	9 1/8	
14	4 1/2	3 1/4-12	4 1/4-12	4 1/2	5 1/4	1	Δ	1/2	1 1/2	3 1/2	7 1/8	9 1/8	
	5	3 1/2-12	4 3/4-12	5	5 3/4	1	Δ	1/2	1 1/2	3 1/2	7 5/8	9 1/8	
	5 1/2	4-12	5 1/4-12	5 1/2	6 1/4	1	Δ	1/2	1 1/2	3 1/2	8 3/8	9 1/8	
	2 1/2	1 7/8-12	2 1/4-12	3	3 1/8	1	2 1/8	1/2	1 1/2	3 13/16	4 7/16	10 3/8	
	3	2 1/4-12	2 3/4-12	3 1/2	3 3/4	1	2 5/8	1/2	1 1/2	3 13/16	5 1/4	10 3/8	
	3 1/2	2 1/2-12	3 1/4-12	3 1/2	4 1/4	1	3	1/2	1 1/2	3 13/16	5 5/8	10 3/8	
	4	3-12	3 3/4-12	4	4 3/4	1	Δ	1/2	1 1/2	3 13/16	6 7/16	10 3/8	
16	4 1/2	3 1/4-12	4 1/4-12	4 1/2	5 1/4	1	Δ	1/2	1 1/2	3 13/16	7 1/8	10 3/8	
	5	3 1/2-12	4 3/4-12	5	5 3/4	1	Δ	1/2	1 1/2	3 13/16	7 5/8	10 3/8	
	5 1/2	4-12	5 1/4-12	5 1/2	6 1/4	1	Δ	1/2	1 1/2	3 13/16	8 3/8	10 3/8	
	3 1/2	2 1/2-12	3 1/4-12	3 1/2	4 1/4	1	3	1/2	1 1/2	3 5/8	5 5/8	11 1/2	
	4	3-12	3 3/4-12	4	4 3/4	1	Δ	1/2	1 1/2	3 5/8	6 7/16	11 1/2	
	4 1/2	3 1/4-12	4 1/4-12	4 1/2	5 1/4	1	Δ	1/2	1 1/2	3 5/8	7 1/8	11 1/2	
	5	3 1/2-12	4 3/4-12	5	5 3/4	1	Δ	1/2	1 1/2	3 5/8	7 5/8	11 1/2	
18	5 1/2	4-12	5 1/4-12	5 1/2	6 1/4	1	Δ	1/2	1 1/2	3 5/8	8 3/8	11 1/2	
	4	3-12	3 3/4-12	4	4 3/4	1	Δ	3/8	1 3/8	4 1/8	6 7/16	12 1/2	
	4 1/2	3 1/4-12	4 1/4-12	4 1/2	5 1/4	1	Δ	3/8	1 3/8	4 1/8	7 1/8	12 1/2	
	5	3 1/2-12	4 3/4-12	5	5 3/4	1	Δ	3/8	1 3/8	4 1/8	7 5/8	12 1/2	
20	5 1/2	4-12	5 1/4-12	5 1/2	6 1/4	1	Δ	3/8	1 3/8	4 1/8	8 3/8	12 1/2	
	4	3-12	3 3/4-12	4	4 3/4	1	Δ	3/8	1 3/8	4 7/16	6 7/16	14	
	4 1/2	3 1/4-12	4 1/4-12	4 1/2	5 1/4	1	Δ	3/8	1 3/8	4 7/16	7 1/8	14	
	5	3 1/2-12	4 3/4-12	5	5 3/4	1	Δ	3/8	1 3/8	4 7/16	7 5/8	14	
	5 1/2	4-12	5 1/4-12	5 1/2	6 1/4	1	Δ	3/8	1 3/8	4 7/16	8 3/8	14	

Δ (4) SPANNER HOLES USED INSTEAD OF FLATS ON 4" DIA. AND LARGER RODS
‡ B DIMENSION TOLERANCE -.001/-.003



NO TIE RODS EXTENDED MOUNT

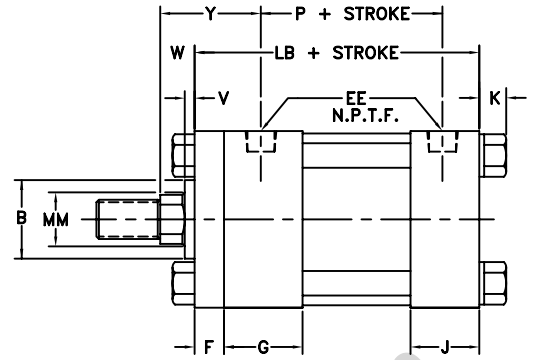
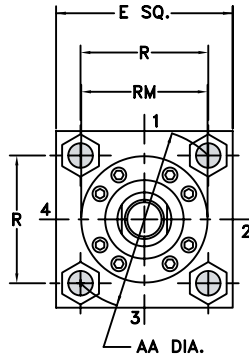
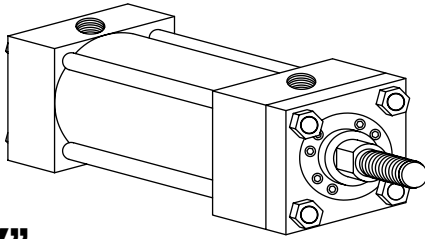

“K”

YATES STYLE **K**
NFPA-MX0

BOTH ENDS TIE RODS EXTENDED MOUNT

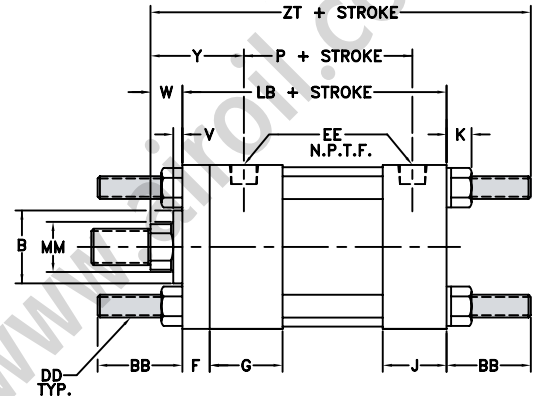
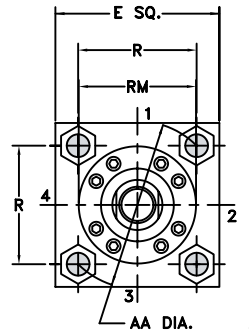
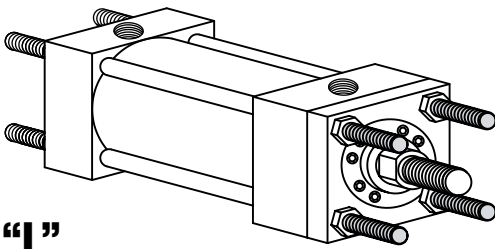

“L”

YATES STYLE **L**
NFPA-MX1

HEAD TIE RODS EXTENDED MOUNT

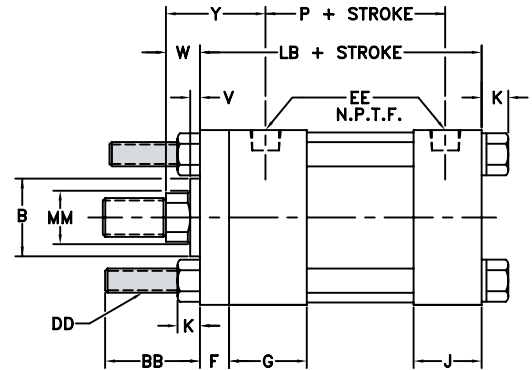
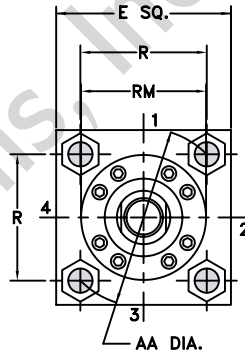
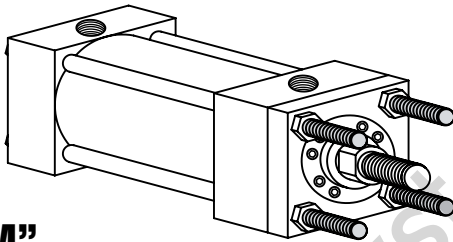

“M”

YATES STYLE **M**
NFPA-MX3

CAP TIE RODS EXTENDED MOUNT

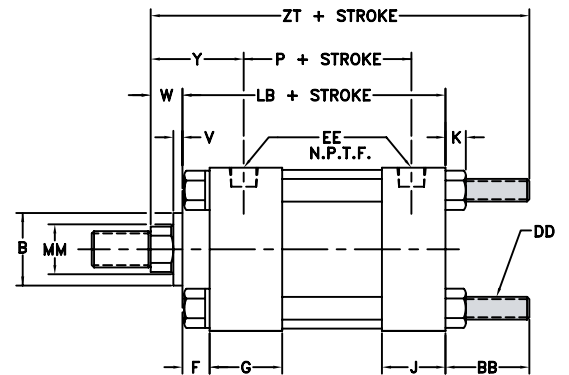
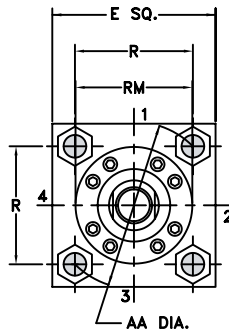
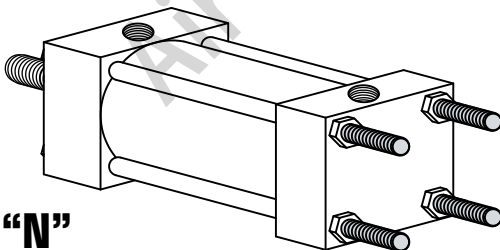

“N”

YATES STYLE **N**
NFPA-MX2

STANDARD ROD ENDS

#2 STD MALE NFPA-SM

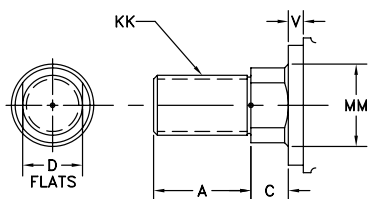

#4 STD FEMALE NFPA-SF

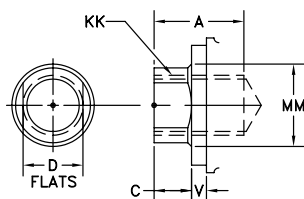

#1 MALE NFPA-IM

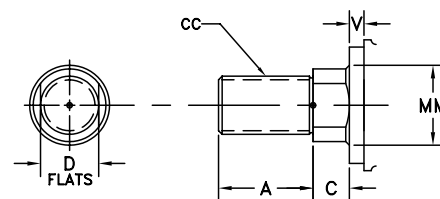

BORE	SAE											ADD STROKE	
	E	EE	OPT	F	G	J	K	AA	BB	DD	R	LB	P
1 1/2	2	3/8	6	3/8	1 1/2	1	1/4	2.02	1	1/4-28	1.43	4	2 3/16
2	2 1/2	3/8	6	3/8	1 1/2	1	5/16	2.60	1 1/8	5/16-24	1.84	4	2 3/16
2 1/2	3	3/8	6	3/8	1 1/2	1	5/16	3.10	1 1/8	5/16-24	2.19	4 1/8	2 5/16
3 1/4	3 3/4	1/2	10	5/8	1 3/4	1 1/4	3/8	3.90	1 3/8	3/8-24	2.76	4 7/8	2 5/8
4	4 1/2	1/2	10	5/8	1 3/4	1 1/4	3/8	4.70	1 3/8	3/8-24	3.32	4 7/8	2 5/8
5	5 1/2	1/2	10	5/8	1 3/4	1 1/4	7/16	5.80	1 13/16	1/2-20	4.10	5 1/8	2 7/8
6	6 1/2	3/4	12	3/4	2	1 1/2	7/16	6.90	1 13/16	1/2-20	4.88	5 3/4	3 1/8

BORE	ROD DIA.	THREAD		ROD EXTENSIONS AND PILOT DIMENSION								ADD STROKE
	MM	KK	CC	A	B ±	C	D	V	W	RM	Y	ZT*
1 1/2	5/8	7/16-20	1/2-20	3/4	1 1/8	3/8	1/2	1/4	5/8	§	1 31/32	5 5/8
	1†Ω	3/4-16	7/8-14	1 1/8	1 1/2	1/2	7/8	1/2	1	§	2 11/32	6
2	5/8	7/16-20	1/2-20	3/4	1 1/8	3/8	1/2	1/4	5/8	§	1 31/32	5 3/4
	1	3/4-16	7/8-14	1 1/8	1 1/2	1/2	7/8	1/2	1	§	2 11/32	6 1/8
2 1/2	1 3/8†Ω	1-14	1 1/4-12	1 5/8	2	5/8	1 1/8	5/8	1 1/4	§	2 19/32	6 3/8
	5/8	7/16-20	1/2-20	3/4	1 1/8	3/8	1/2	1/4	5/8	§	1 31/32	5 7/8
	1	3/4-16	7/8-14	1 1/8	1 1/2	1/2	7/8	1/2	1	2 5/8	2 11/32	6 1/4
3 1/4	1 3/8	1-14	1 1/4-12	1 5/8	2	5/8	1 1/8	5/8	1 1/4	§	2 19/32	6 1/2
	1 3/4†Ω	1 1/4-12	1 1/2-12	2	2 3/8	3/4	1 1/2	3/4	1 1/2	§	2 27/32	6 3/4
	1	3/4-16	7/8-14	1 1/8	1 1/2	1/2	7/8	1/4	3/4	§	2 7/16	7
	1 3/8	1-14	1 1/4-12	1 5/8	2	5/8	1 1/8	3/8	1	3 7/32	2 11/16	7 1/4
4	1 3/4	1 1/4-12	1 1/2-12	2	2 3/8	3/4	1 1/2	1/2	1 1/4	§	2 15/16	7 1/2
	2†	1 1/2-12	1 3/4-12	2 1/4	2 5/8	7/8	1 3/4	1/2	1 3/8	§	3 1/16	7 5/8
	1	3/4-16	7/8-14	1 1/8	1 1/2	1/2	7/8	1/4	3/4	§	2 7/16	7
	1 3/8	1-14	1 1/4-12	1 5/8	2	5/8	1 1/8	3/8	1	3 7/32	2 11/16	7 1/4
	1 3/4	1 1/4-12	1 1/2-12	2	2 3/8	3/4	1 1/2	1/2	1 1/4	3 7/8	2 15/16	7 1/2
5	2	1 1/2-12	1 3/4-12	2 1/4	2 5/8	7/8	1 3/4	1/2	1 3/8	4	3 1/16	7 5/8
	2 1/2†	1 7/8-12	2 1/4-12	3	3 1/8	1	2 1/8	5/8	1 5/8	§	3 5/16	7 7/8
	1	3/4-16	7/8-14	1 1/8	1 1/2	1/2	7/8	1/4	3/4	§	2 7/16	7 11/16
	1 3/8	1-14	1 1/4-12	1 5/8	2	5/8	1 1/8	3/8	1	3 7/32	2 11/16	7 15/16
	1 3/4	1 1/4-12	1 1/2-12	2	2 3/8	3/4	1 1/2	1/2	1 1/4	3 7/8	2 15/16	8 3/16
	2	1 1/2-12	1 3/4-12	2 1/4	2 5/8	7/8	1 3/4	1/2	1 3/8	4	3 1/16	8 5/16
	2 1/2	1 7/8-12	2 1/4-12	3	3 1/8	1	2 1/8	5/8	1 5/8	4 7/16	3 5/16	8 9/16
6	3	2 1/4-12	2 3/4-12	3 1/2	3 3/4	1	2 5/8	5/8	1 5/8	§	3 5/16	8 9/16
	3 1/2†	2 1/2-12	3 1/4-12	3 1/2	4 1/4	1	3	5/8	1 5/8	§	3 5/16	8 9/16
	1 3/8	1-14	1 1/4-12	1 5/8	2	5/8	1 1/8	1/4	7/8	§	2 13/16	8 7/16
	1 3/4	1 1/4-12	1 1/2-12	2	2 3/8	3/4	1 1/2	3/8	1 1/8	3 7/8	3 1/16	8 11/16
	2	1 1/2-12	1 3/4-12	2 1/4	2 5/8	7/8	1 3/4	3/8	1 1/4	4	3 3/16	8 13/16
	2 1/2	1 7/8-12	2 1/4-12	3	3 1/8	1	2 1/8	1/2	1 1/2	4 7/16	3 7/16	9 1/16
	3	2 1/4-12	2 3/4-12	3 1/2	3 3/4	1	2 5/8	1/2	1 1/2	5 1/4	3 7/16	9 1/16
	3 1/2	2 1/2-12	3 1/4-12	3 1/2	4 1/4	1	3	1/2	1 1/2	5 5/8	3 7/16	9 1/16
4	3-12	3 3/4-12	4	4 3/4	1	Δ	1/2	1 1/2	§	3 7/16	9 1/16	

† HEAD END PORTS SHALLOW TAPPED
 Ω FIXED CUSHIONS FURNISHED AT THE HEAD END IN THESE SIZES
 § THESE CYLINDERS HAVE FULL PLATE RETAINERS. USE "E" DIMENSION INSTEAD OF "RM" - SEE PAGE 42

NOTE: 1 1/2" AND 2" BORE CYLINDERS ON K AND N MOUNTS AND 1 1/2" THRU 6" BORE CYLINDERS ON L AND M MOUNTS HAVE FULL PLATE RETAINERS. USE "E" SQ. DIMENSION INSTEAD OF "RM"



NO TIE RODS EXTENDED MOUNT

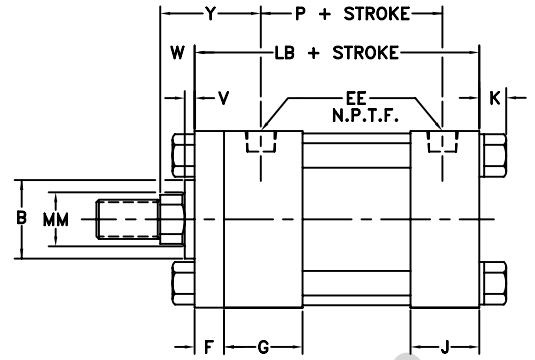
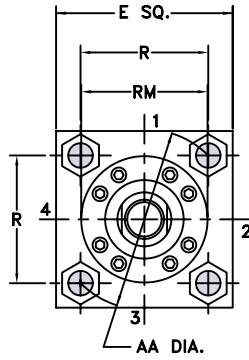
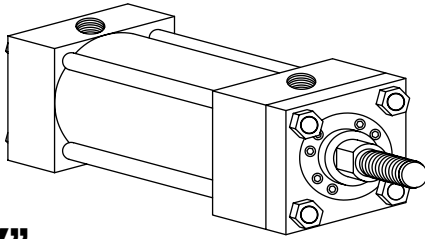

“K”

YATES STYLE **K**
NFPA-MX0

BOTH ENDS TIE RODS EXTENDED MOUNT

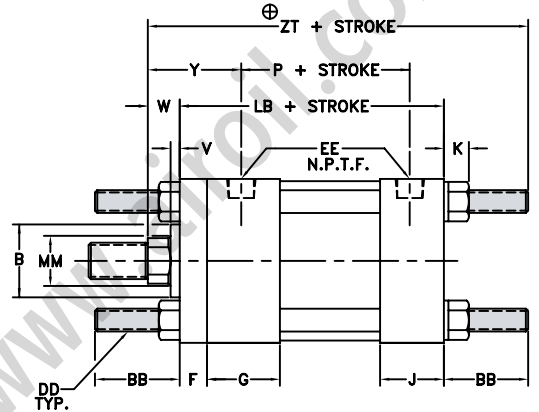
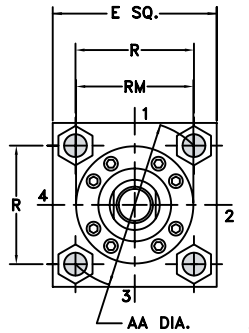
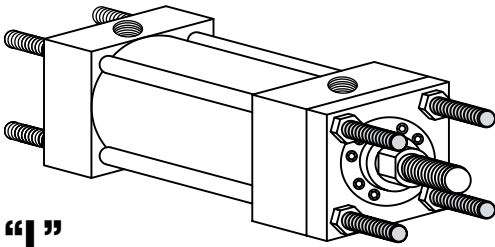

“L”

YATES STYLE **L**
NFPA-MX1

HEAD TIE RODS EXTENDED MOUNT

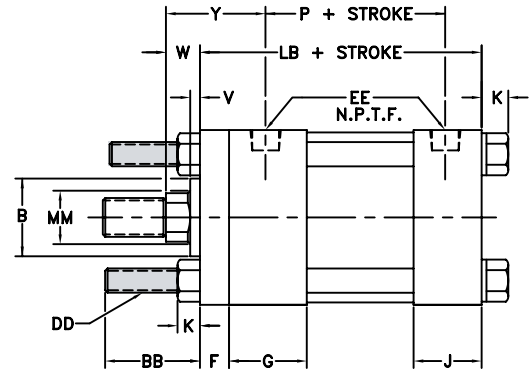
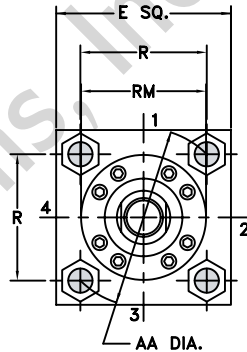
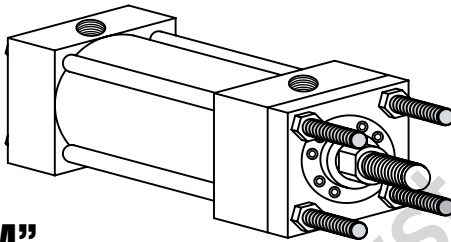

“M”

YATES STYLE **M**
NFPA-MX3

CAP TIE RODS EXTENDED MOUNT

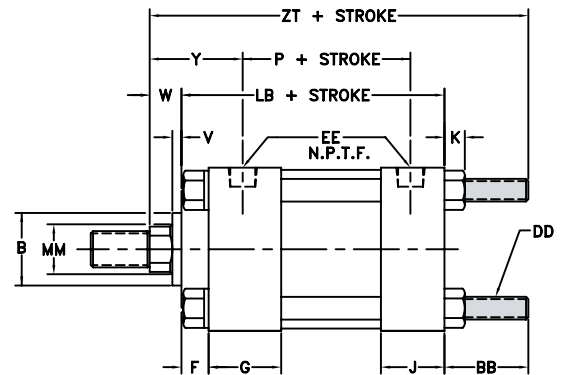
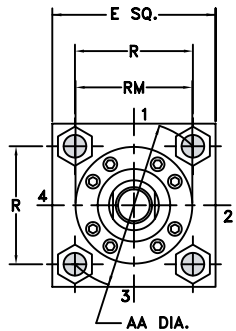
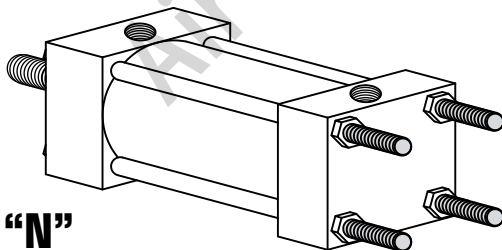

“N”

YATES STYLE **N**
NFPA-MX2

BORE	SAE											ADD STROKE	
	E	EE	OPT	F	G	J	K	AA	BB	DD	R	LB	P
8	8 1/2	3/4	12	3/4	2	1 1/2	9/16	9.11	2 5/16	5/8-18	6.44	5 7/8	3 1/4
10	10 5/8	1	16	3/4	2 1/4	2	11/16	11.20	2 11/16	3/4-16	7.92	7 1/8	4 1/8
12	12 3/4	1	16	3/4	2 1/4	2	11/16	13.29	2 11/16	3/4-16	9.40	7 5/8	4 5/8
14	14 3/4	1 1/4	20	3/4	2 3/4	2 1/4	13/16	15.41	3 3/16	7/8-14	10.90	8 7/8	5 1/2
16	17 1/2	1 1/2	24	3/4	2 15/16	2 15/16	15/16	18.25	3 5/8	1-14	Δ	10	6 1/2
18	19 1/2	1 1/2	24	7/8	3 7/16	3 7/16	1	20.50	4 1/8	1 1/8-12	Δ	11 1/8	6 1/2
20	21 3/4	2	32	7/8	3 15/16	3 15/16	1 1/8	22.62	4 1/2	1 1/4-12	Δ	12 5/8	7 3/8

BORE	ROD DIA. MM	THREAD		ROD EXTENSIONS AND PILOT DIMENSION								ADD STROKE ZT*	
		KK	CC	A	B ‡	C	D	V	W	RM	Y		
8	1 3/8	1-14	1 1/4-12	1 5/8	2	5/8	1 1/8	1/4	7/8	3 7/32	2 13/16	9 1/16	
	1 3/4	1 1/4-12	1 1/2-12	2	2 3/8	3/4	1 1/2	3/8	1 1/8	3 7/8	3 1/16	9 5/16	
	2	1 1/2-12	1 3/4-12	2 1/4	2 5/8	7/8	1 3/4	3/8	1 1/4	4	3 3/16	9 7/16	
	2 1/2	1 7/8-12	2 1/4-12	3	3 1/8	1	2 1/8	1/2	1 1/2	4 7/16	3 7/16	9 11/16	
	3	2 1/4-12	2 3/4-12	3 1/2	3 3/4	1	2 5/8	1/2	1 1/2	5 1/4	3 7/16	9 11/16	
	3 1/2	2 1/2-12	3 1/4-12	3 1/2	4 1/4	1	3	1/2	1 1/2	5 5/8	3 7/16	9 11/16	
	4	3-12	3 3/4-12	4	4 3/4	1	Δ	1/2	1 1/2	6 7/16	3 7/16	9 11/16	
	4 1/2	3 3/4-12	4 1/4-12	4 1/2	5 1/4	1	Δ	1/2	1 1/2	7 1/8	3 7/16	9 11/16	
	5	3 1/2-12	4 3/4-12	5	5 3/4	1	Δ	1/2	1 1/2	7 5/8	3 7/16	9 11/16	
	10	1 3/4	1 1/4-12	1 1/2-12	2	2 3/8	3/4	1 1/2	3/8	1 1/8	3 7/8	3 1/8	10 15/16
2		1 1/2-12	1 3/4-12	2 1/4	2 5/8	7/8	1 3/4	3/8	1 1/4	4	3 1/4	11 1/16	
2 1/2		1 7/8-12	2 1/4-12	3	3 1/8	1	2 1/8	1/2	1 1/2	4 7/16	3 1/2	11 5/16	
3		2 1/4-12	2 3/4-12	3 1/2	3 3/4	1	2 5/8	1/2	1 1/2	5 1/4	3 1/2	11 5/16	
3 1/2		2 1/2-12	3 1/4-12	3 1/2	4 1/4	1	3	1/2	1 1/2	5 5/8	3 1/2	11 5/16	
4		3-12	3 3/4-12	4	4 3/4	1	Δ	1/2	1 1/2	6 7/16	3 1/2	11 5/16	
4 1/2		3 1/4-12	4 1/4-12	4 1/2	5 1/4	1	Δ	1/2	1 1/2	7 1/8	3 1/2	11 5/16	
5		3 1/2-12	4 3/4-12	5	5 3/4	1	Δ	1/2	1 1/2	7 5/8	3 1/2	11 5/16	
5 1/2		4-12	5 1/4-12	5 1/2	6 1/4	1	Δ	1/2	1 1/2	8 3/8	3 1/2	11 5/16	
12		2	1 1/2-12	1 3/4-12	2 1/4	2 5/8	7/8	1 3/4	3/8	1 1/4	4	3 1/4	11 9/16
	2 1/2	1 7/8-12	2 1/4-12	3	3 1/8	1	2 1/8	1/2	1 1/2	4 7/16	3 1/2	11 13/16	
	3	2 1/4-12	2 3/4-12	3 1/2	3 3/4	1	2 5/8	1/2	1 1/2	5 1/4	3 1/2	11 13/16	
	3 1/2	2 1/2-12	3 1/4-12	3 1/2	4 1/4	1	3	1/2	1 1/2	5 5/8	3 1/2	11 13/16	
	4	3-12	3 3/4-12	4	4 3/4	1	Δ	1/2	1 1/2	6 7/16	3 1/2	11 13/16	
	4 1/2	3 1/4-12	4 1/4-12	4 1/2	5 1/4	1	Δ	1/2	1 1/2	7 1/8	3 1/2	11 13/16	
	5	3 1/2-12	4 3/4-12	5	5 3/4	1	Δ	1/2	1 1/2	7 5/8	3 1/2	11 13/16	
	5 1/2	4-12	5 1/4-12	5 1/2	6 1/4	1	Δ	1/2	1 1/2	8 3/8	3 1/2	11 13/16	
	14	2 1/2	1 7/8-12	2 1/4-12	3	3 1/8	1	2 1/8	1/2	1 1/2	4 7/16	3 13/16	13 9/16
		3	2 1/4-12	2 3/4-12	3 1/2	3 3/4	1	2 5/8	1/2	1 1/2	5 1/4	3 13/16	13 9/16
3 1/2		2 1/2-12	3 1/4-12	3 1/2	4 1/4	1	3	1/2	1 1/2	5 5/8	3 13/16	13 9/16	
4		3-12	3 3/4-12	4	4 3/4	1	Δ	1/2	1 1/2	6 7/16	3 13/16	13 9/16	
4 1/2		3 1/4-12	4 1/4-12	4 1/2	5 1/4	1	Δ	1/2	1 1/2	7 1/8	3 13/16	13 9/16	
5		3 1/2-12	4 3/4-12	5	5 3/4	1	Δ	1/2	1 1/2	7 5/8	3 13/16	13 9/16	
5 1/2		4-12	5 1/4-12	5 1/2	6 1/4	1	Δ	1/2	1 1/2	8 3/8	3 13/16	13 9/16	
16		3 1/2	2 1/2-12	3 1/4-12	3 1/2	4 1/4	1	3	1/2	1 1/2	5 5/8	3 5/8	15 1/8
		4	3-12	3 3/4-12	4	4 3/4	1	Δ	1/2	1 1/2	6 7/16	3 5/8	15 1/8
		4 1/2	3 1/4-12	4 1/4-12	4 1/2	5 1/4	1	Δ	1/2	1 1/2	7 1/8	3 5/8	15 1/8
	5	3 1/2-12	4 3/4-12	5	5 3/4	1	Δ	1/2	1 1/2	7 5/8	3 5/8	15 1/8	
	5 1/2	4-12	5 1/4-12	5 1/2	6 1/4	1	Δ	1/2	1 1/2	8 3/8	3 5/8	15 1/8	
	18	4	3-12	3 3/4-12	4	4 3/4	1	Δ	3/8	1 3/8	6 7/16	4 1/8	16 5/8
		4 1/2	3 1/4-12	4 1/4-12	4 1/2	5 1/4	1	Δ	3/8	1 3/8	7 1/8	4 1/8	16 5/8
		5	3 1/2-12	4 3/4-12	5	5 3/4	1	Δ	3/8	1 3/8	7 5/8	4 1/8	16 5/8
		5 1/2	4-12	5 1/4-12	5 1/2	6 1/4	1	Δ	3/8	1 3/8	8 3/8	4 1/8	16 5/8
		20	4	3-12	3 3/4-12	4	4 3/4	1	Δ	3/8	1 3/8	6 7/16	4 7/16
4 1/2			3 1/4-12	4 1/4-12	4 1/2	5 1/4	1	Δ	3/8	1 3/8	7 1/8	4 7/16	18 1/2
5			3 1/2-12	4 3/4-12	5	5 3/4	1	Δ	3/8	1 3/8	7 5/8	4 7/16	18 1/2
5 1/2			4-12	5 1/4-12	5 1/2	6 1/4	1	Δ	3/8	1 3/8	8 3/8	4 7/16	18 1/2

Δ (4) SPANNER HOLES USED INSTEAD OF FLATS ON 4" DIA. AND LARGER RODS
‡ B DIMENSION TOLERANCE -.001/-.003
Φ FOR 16-20" BORES, SEE PAGE 42 FOR TIE ROD INFORMATION
* ZT DIMENSION CHANGES ON DOUBLE ROD CYLINDERS - SEE PAGE 72 FOR DETAILS



DOUBLE ROD END DIMENSIONS

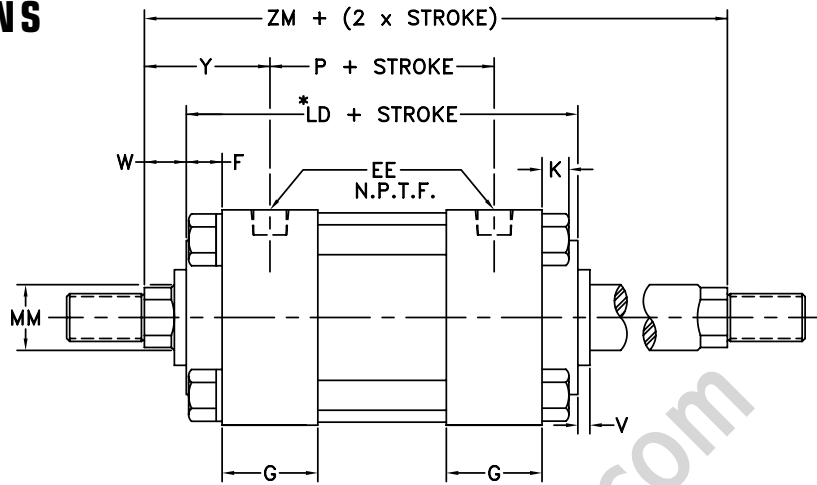
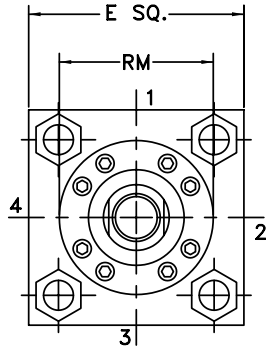

BORE	ROD DIA. MM	ADD STROKE						ZM
		L _D *	SE _D	SS _D	XE _D	ZE _D	ZT _D	
1 1/2	5/8	4 7/8	6 3/8	3 3/8	6 1/4	6 1/2	6 1/2	6 1/8
	1	4 7/8	6 3/8	3 3/8	6 5/8	6 7/8	6 7/8	6 7/8
	1 3/8	4 7/8	6 3/4	3 3/8	6 13/16	7 1/8	7	6 7/8
2	5/8	4 7/8	6 3/4	3 3/8	6 7/16	6 3/4	6 5/8	6 1/8
	1	4 7/8	6 3/4	3 3/8	6 13/16	7 1/8	7	6 7/8
	1 3/8	4 7/8	6 3/4	3 3/8	7 1/16	7 3/8	7 1/4	7 3/8
2 1/2	5/8	5	7 1/8	3 1/2	6 11/16	7	6 3/4	6 1/4
	1	5	7 1/8	3 1/2	7 1/16	7 3/8	7 1/8	7
	1 3/8	5	7 1/8	3 1/2	7 5/16	7 5/8	7 3/8	7 1/2
3 1/4	5/8	5	7 1/8	3 1/2	7 9/16	7 7/8	7 5/8	8
	1	6	7 3/4	3 3/4	7 5/8	8	8 1/8	7 1/2
	1 3/8	6	7 3/4	3 3/4	7 7/8	8 1/4	8 3/8	8
4	1	6	7 3/4	3 3/4	8 1/8	8 1/2	8 5/8	8 1/2
	1 3/8	6	7 3/4	3 3/4	8 1/4	8 5/8	8 3/4	8 3/4
	1 3/4	6	7 3/4	3 3/4	8 1/4	8 5/8	8 5/8	8 1/2
5	1	6	8	3 3/4	8 3/8	8 3/4	8 3/4	8 3/4
	1 3/8	6	8	3 3/4	8 3/8	8 3/4	8 3/4	8 3/4
	1 3/4	6	8	3 3/4	8 3/8	8 3/4	8 3/4	8 3/4
6	1	6	8	3 3/4	8 3/8	8 3/4	8 3/4	8 3/4
	1 3/8	6	8	3 3/4	8 3/8	8 3/4	8 3/4	8 3/4
	1 3/4	6	8	3 3/4	8 3/8	8 3/4	8 3/4	8 3/4
7	1	6	8	3 3/4	8 3/8	8 3/4	8 3/4	8 3/4
	1 3/8	6	8	3 3/4	8 3/8	8 3/4	8 3/4	8 3/4
	1 3/4	6	8	3 3/4	8 3/8	8 3/4	8 3/4	8 3/4
8	1	6	8	3 3/4	8 3/8	8 3/4	8 3/4	8 3/4
	1 3/8	6	8	3 3/4	8 3/8	8 3/4	8 3/4	8 3/4
	1 3/4	6	8	3 3/4	8 3/8	8 3/4	8 3/4	8 3/4

DOUBLE ROD END STYLES

AVAILABLE IN MOUNTING STYLES

A, B, E, F, G, H, J, K, L, M, T, U, AND X

ALL DIMENSIONS APPLY TO STANDARD ROD SIZES

*"LD" replaces "LB" dimensions on all styles with double rod ends.

FOR ORDERING DOUBLE ROD END CYLINDERS

ADD "D" AFTER STYLE

Example: Style "A" side lug mount with double rod end is style "A4AD".

Where the two rod ends will be different, state which rod end is to go at which end of cylinder.

If only one end of double rod cylinder is to be cushioned, specify clearly which end.

EXTENDED KEY PLATE MOUNTINGS

FOR ORDERING EXTENDED KEY PLATE add "S" in part # & state extended key plate in description available in mounting styles "A", "B", and "E"

BORE	FA	FE
1 1/2	.362	3/16
2	.362	3/16
2 1/2	.362	3/16
3 1/4	.612	5/16
4	.612	5/16
5	.612	5/16
6	.737	3/8

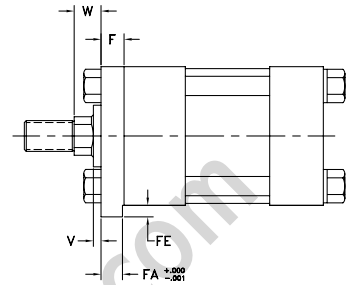

BORE	ROD DIA. MM	ADD STROKE						ZM
		L _D *	SE _D	SS _D	XE _D	ZE _D	ZT _D	
10	1 3/4	8 1/8	9 1/4	4 7/8	9 13/16	10 7/16	11 3/16	10 3/8
	2	8 1/8	9 1/4	4 7/8	9 15/16	10 9/16	11 5/16	10 5/8
	2 1/2	8 1/8	9 1/4	4 7/8	10 3/16	10 13/16	11 9/16	11 1/8
	3	8 1/8	9 1/4	4 7/8	10 3/16	10 13/16	11 9/16	11 1/8
	3 1/2	8 1/8	9 1/4	4 7/8	10 3/16	10 13/16	11 9/16	11 1/8
	4	8 1/8	9 1/4	4 7/8	10 3/16	10 13/16	11 9/16	11 1/8
	4 1/2	8 1/8	9 1/4	4 7/8	10 3/16	10 13/16	11 9/16	11 1/8
	5	8 1/8	9 1/4	4 7/8	10 3/16	10 13/16	11 9/16	11 1/8
	5 1/2	8 1/8	9 1/4	4 7/8	10 3/16	10 13/16	11 9/16	11 1/8
	12	2	8 5/8	9 3/4	5 3/8	10 7/16	11 1/16	11 13/16
2 1/2		8 5/8	9 3/4	5 3/8	10 11/16	11 5/16	12 1/16	11 5/8
3		8 5/8	9 3/4	5 3/8	10 11/16	11 5/16	12 1/16	11 5/8
3 1/2		8 5/8	9 3/4	5 3/8	10 11/16	11 5/16	12 1/16	11 5/8
4		8 5/8	9 3/4	5 3/8	10 11/16	11 5/16	12 1/16	11 5/8
4 1/2		8 5/8	9 3/4	5 3/8	10 11/16	11 5/16	12 1/16	11 5/8
5		8 5/8	9 3/4	5 3/8	10 11/16	11 5/16	12 1/16	11 5/8
14	2 1/2	10 1/8	11 5/8	6 3/8	12 3/8	13 1/8	14 1/16	13 1/8
	3	10 1/8	11 5/8	6 3/8	12 3/8	13 1/8	14 1/16	13 1/8
	3 1/2	10 1/8	11 5/8	6 3/8	12 3/8	13 1/8	14 1/16	13 1/8
	4	10 1/8	11 5/8	6 3/8	12 3/8	13 1/8	14 1/16	13 1/8
	4 1/2	10 1/8	11 5/8	6 3/8	12 3/8	13 1/8	14 1/16	13 1/8
	5	10 1/8	11 5/8	6 3/8	12 3/8	13 1/8	14 1/16	13 1/8
16	3 1/2	10 3/4	NA	5 3/4	NA	NA	15 1/8	13 3/4
	4	10 3/4	NA	5 3/4	NA	NA	15 1/8	13 3/4
	4 1/2	10 3/4	NA	5 3/4	NA	NA	15 1/8	13 3/4
	5	10 3/4	NA	5 3/4	NA	NA	15 1/8	13 3/4
	5 1/2	10 3/4	NA	5 3/4	NA	NA	15 1/8	13 3/4
18	4	12	NA	6 1/4	NA	NA	16 5/8	14 3/4
	4 1/2	12	NA	6 1/4	NA	NA	16 5/8	14 3/4
	5	12	NA	6 1/4	NA	NA	16 5/8	14 3/4
	5 1/2	12	NA	6 1/4	NA	NA	16 5/8	14 3/4
20	4	13 1/2	NA	7	NA	NA	18 1/2	16 1/4
	4 1/2	13 1/2	NA	7	NA	NA	18 1/2	16 1/4
	5	13 1/2	NA	7	NA	NA	18 1/2	16 1/4
	5 1/2	13 1/2	NA	7	NA	NA	18 1/2	16 1/4



FEMALE CLEVIS

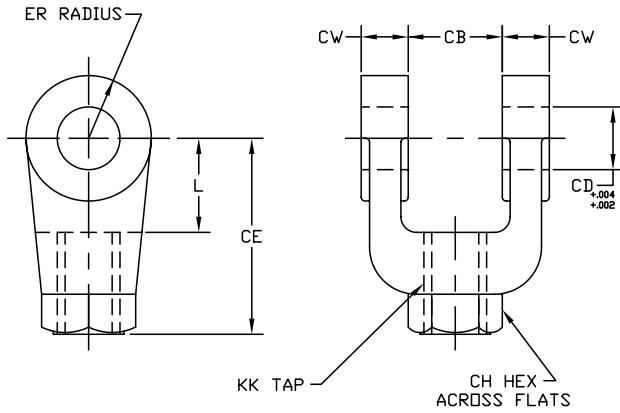

PART NO.	CB	CD	CE	CH	CW	ER	KK	L
10-YFC-134-05-A	3/4	1/2	1 1/2	1	1/2	1/2	7/16-20	3/4
10-YFC-134-08-A	1 1/4	3/4	2 3/8	1 1/4	5/8	3/4	3/4-16	1 1/4
10-YFC-134-08-M	1 1/4	3/4	2 1/8	1 3/8	5/8	3/4	3/4-16	1
10-YFC-134-11-A	1 1/2	1	3 1/8	1 1/2	3/4	1	1-14	1 1/2
10-YFC-134-11-M	1 1/2	1	2 15/16	1 1/2	3/4	1	1-14	1 5/16
10-YFC-134-14-A	2	1 3/8	4 1/8	2	1	1 3/8	1 1/4-12	2 1/8
10-YFC-134-14-M	2	1 3/8	3 3/4	2	1	1 3/8	1 1/4-12	1 3/4
10-YFC-134-16-A	2 1/2	1 3/4	4 1/2	2 3/8	1 1/4	1 3/4	1 1/2-12	2 1/4
10-YFC-134-20-A	2 1/2	2	5 1/2	2 15/16	1 1/4	2	1 7/8-12	2 1/2
10-YFC-134-24-A	3	2 1/2	6 1/2	3 1/2	1 1/2	2 1/2	2 1/4-12	3
10-YFC-134-28-A	3	3	6 3/4	3 7/8	1 1/2	2 3/4	2 1/2-12	3 1/4
10-YFC-134-28-M	3	3	6 3/4	3 7/8	1 1/2	3	2 1/2-12	3 1/4
10-YFC-134-36-A	4	3 1/2	8 1/2	5	2	3 1/2	3 1/4-12	4
10-YFC-134-36-M	4	3 1/2	7 3/4	5	2	3 1/2	3 1/4-12	4 1/4
10-YFC-134-44-A	4 1/2	4	10	6 1/8	2 1/4	4	4-12	4 1/2

ROD COUPLERS

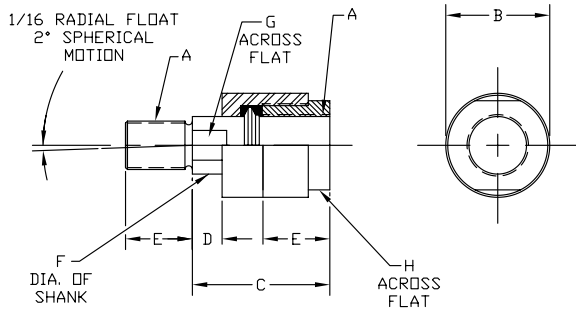

PART NUMBER	ROD DIA.	A	B	C	D	E	F	G	H	MAX PULL
11-YAC-2-05	5/8	7/16-20	1 1/4	2	1/2	3/4	5/8	1/2	1	10,000
11-YAC-2-06	5/8	1/2-20	1 1/4	2	1/2	3/4	5/8	1/2	1	14,000
11-YAC-2-07	5/8	5/8-18	1 1/4	2	1/2	3/4	5/8	1/2	1	19,000
11-YAC-2-08	1	3/4-16	1 3/4	2 5/16	1/2	1 1/8	31/32	13/16	1 1/2	34,000
11-YAC-2-09	1	7/8-14	1 3/4	2 5/16	1/2	1 1/8	31/32	13/16	1 1/2	39,000
11-YAC-2-11	1 3/8	1-14	2 1/2	2 15/16	1/2	1 5/8	1 3/8	1 5/32	2 1/4	64,000
11-YAC-2-14	1 3/8	1 1/4-12	2 1/2	2 15/16	1/2	1 5/8	1 3/8	1 5/32	2 1/4	78,000
11-YAC-2-15	1 3/8	1 3/8-12	2 1/2	2 15/16	1/2	1 5/8	1 3/8	1 5/32	2 1/4	78,000
11-YAC-2-16	2	1 1/2-12	3 1/4	4 3/8	13/16	2 1/4	1 3/4	1 1/2	3	134,000
11-YAC-2-17	2	1 3/4-12	3 1/4	4 3/8	13/16	2 1/4	1 3/4	1 1/2	3	134,000
11-YAC-2-20	2 1/2	1 7/8-12	3 3/4	5 7/16	7/8	3	2	1 7/8	3 1/2	240,000
11-YAC-2-21	2 1/2	2-12	3 3/4	5 7/16	7/8	3	2	1 7/8	3 1/2	240,000
11-YAC-2-24	3	2 1/4-12	6 3/4	6 3/8	1	3 1/2	2 3/4	2 3/8	4 1/2	397,000
11-YAC-2-28	3 1/2	2 1/2-12	7	6 1/2	1	3 1/2	3 1/4	2 7/8	3 3/8	495,000
11-YAC-2-29	3 1/2	2 3/4-12	7	6 1/2	1	3 1/2	3 1/4	2 7/8	3 3/8	603,000
11-YAC-2-36	4 1/2	3 1/4-12	9 1/4	8 1/2	5 1/4	4 1/2	4	3 3/8	4 1/2	853,800
11-YAC-2-37	4 1/2	4 1/4-12	12 7/8	11 1/4	7 3/4	4 1/2	5 1/2	4 7/8	7	1,483,400

CLEVIS BRACKET

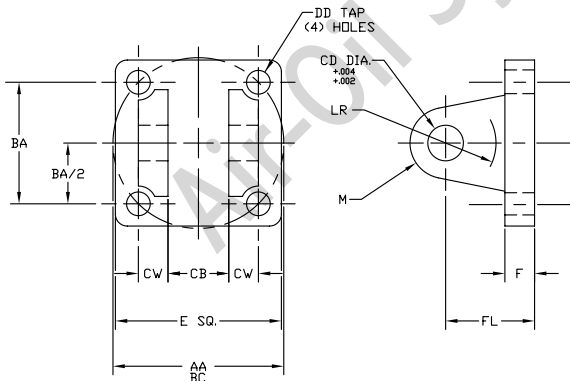

PART NUMBER	AA	BA	CB	CD	CW	DD	E	F	FL	LR	M
14-YCB-133-03	2.3	1 5/8	25/32	1/2	1/2	5/8-24	2 1/2	3/8	1 1/8	1/2	1/2
14-YCB-133-04	2.9	2 1/16	1 9/32	3/4	5/8	1/2-20	3	5/8	1 7/8	1	3/4
14-YCB-133-05	3.6	2 9/16	1 9/32	3/4	5/8	1/2-20	3 1/2	5/8	1 7/8	1 1/16	3/4
14-YCB-133-06	4.6	3 1/4	1 17/32	1	3/4	5/8-18	4 1/2	3/4	2 1/4	1 1/4	1
14-YCB-133-08	5.4	3 13/16	2 1/32	1 3/8	1	5/8-18	5	7/8	3	1 7/8	1 3/8
14-YCB-133-10	7.0	4 15/16	2 17/32	1 3/4	1 1/4	7/8-14	6 1/2	7/8	3 1/8	2	1 3/4
14-YCB-133-12	8.1	5 3/4	2 17/32	2	1 1/4	1-14	7 1/2	1	3 1/2	2 1/8	2
14-YCB-133-14	9.3	6 19/32	3 1/32	2 1/2	1 1/2	1 1/8-12	8 1/2	1	4	2 5/8	2 1/2
14-YCB-133-16	10.6	7 1/2	3 1/32	3	1 1/2	1 1/4-12	9 1/2	1	4 1/4	2 7/8	2 3/4
14-YCB-133-20	13.6	9 5/8	4 1/16	3 1/2	2	1 3/4-12	12 5/8	1 11/16	5 11/16	3 5/8	3 1/2
14-YCB-133-24	16.2	11 1/2	4 9/16	4	2 1/4	2-12	14 7/8	1 15/16	6 7/16	4	4



FEMALE EYE

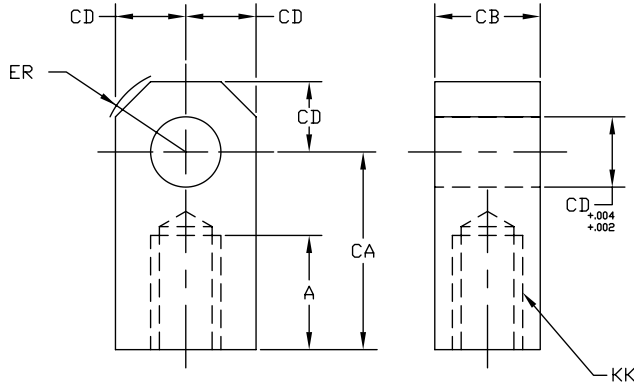

PART NUMBER	A	CA	CB	CD	ER	KK
13-YE-9303	3/4	1/2	3/4	1/2	5/8	7/16-20
13-YE-9304	1 1/8	2 1/16	1 1/4	3/4	7/8	3/4-16
13-YE-9306	1 5/8	2 13/16	1 1/2	1	1 3/16	1-14
13-YE-9306-M	1 1/8	2 3/8	1 1/2	1	1 7/16	7/8-14
13-YE-9308	2	3 7/16	2	1 3/8	1 9/16	1 1/4-12
13-YE-9310	2 1/4	4	2 1/2	1 3/4	2	1 1/2-12
13-YE-9312	3	5	2 1/2	2	2 1/2	1 7/8-12
13-YE-9312-M	2 1/4	4 3/8	2 1/2	2	2 7/8	1 3/4-12
13-YE-9314	3 1/2	5 13/16	3	2 1/2	2 13/16	2 1/4-12
13-YE-9316	3 1/2	6 1/8	3	3	3 1/4	2 1/2-12
13-YE9316-M	3 5/8	6 1/2	3 1/2	3	3 1/4	2 3/4-12
13-YE-9320	4 1/2	7 5/8	4	3 1/2	3 7/8	3 1/4-12
13-YE-9320-M	5	7 5/8	4	3 1/2	3 7/8	3 1/2-12
13-YE-9324	5 1/2	9 1/8	4 1/2	4	4 7/16	4-12
13-YE-9324-M	5 3/4	9 1/8	5	4	4 7/16	4 1/2-12

PIVOT PIN

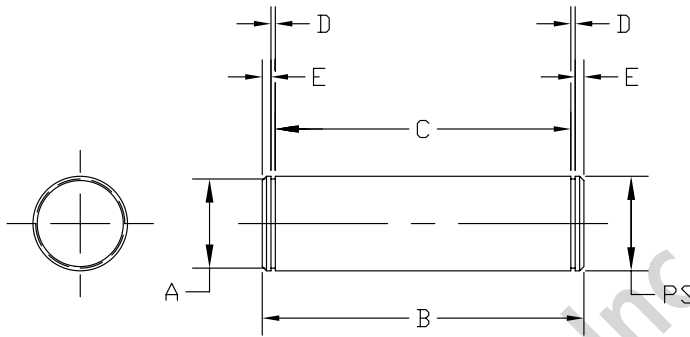

PART NUMBER	PIN SIZE	A	B	C	D	E
12-YP-9003-3-G-A	.500	.470	2.109	1.875	.039	.078
12-YP-9004-3-G-A	.750	.750	2.901	2.625	.046	.092
12-YP-9006-3-G-A	1.000	.943	3.401	3.125	.046	.092
12-YP-9008-3-G-A	1.375	1.295	4.461	4.125	.056	.122
12-YP-9010-3-G-A	1.750	1.655	5.545	5.125	.070	.140
12-YP-9012-3-G-A	2.000	1.891	5.545	5.125	.070	.140
12-YP-9014-3-G-A	2.500	2.366	6.625	6.190	.103	.172
12-YP-9016-3-G-A	3.000	2.844	6.780	6.250	.103	.206
12-YP-9020-3-G-A	3.500	3.322	8.845	8.250	.120	.240
12-YP-9024-3-G-A	4.000	3.782	9.845	9.125	.120	.240

EYE BRACKET

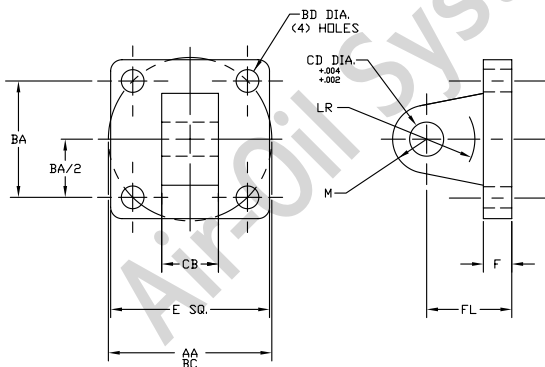

PART NUMBER	AA	BA	BD	CB	CD	E	F	FL	LR	M	M
15-YEB-8903	2.3	1 5/8	13/32	3/4	1/2	2 1/2	3/8	1 1/8	1/2	1/2	1 1/16
15-YEB-8904	3.6	2 9/16	17/32	1 1/4	3/4	3 1/2	5/8	1 7/8	1	3/4	1 3/16
15-YEB-8906	4.6	3 1/4	21/32	1 1/2	1	4 1/2	3/4	2 1/4	1	1	1 3/8
15-YEB-8908	5.4	3 13/16	21/32	2	1 3/8	5	7/8	3	1 1/8	1 3/8	2
15-YEB-8910	7.0	4 15/16	29/32	2 1/2	1 3/4	6 1/2	7/8	3 1/8	1 3/4	1 3/4	2 1/8
15-YEB-8912	8.1	5 3/4	11/32	2	2	7 1/2	1	3 1/2	2	2	2 3/8
15-YEB-8914	9.3	6 19/32	15/32	3	2 1/2	8 1/2	1	4	2 1/2	2 1/2	
15-YEB-8916	10.6	7 1/2	19/32	3	3	9 1/2	1	4 1/4	2 3/4	2 3/4	
15-YEB-8920	13.6	9 5/8	125/32	4	3 1/2	12 5/8	1 11/16	5 11/16	3 1/2	3 1/2	
15-YEB-8924	16.2	11 1/2	2 1/32	4 1/2	4	14 7/8	1 15/16	6 7/16	3 7/8	4	

SWIVEL EYE BRACKET

PART NUMBER	AA	BA	BD	CB	CD	E	F	FL	LR	M
15-YSB-219-3-1	2.3	1 5/8	13/32	3/4	1/2	2 1/2	3/8	1 1/8	1/2	1 1/16
15-YSB-219-3-2	3.6	2 9/16	17/32	1 1/4	3/4	3 1/2	5/8	1 7/8	1	1 3/16
15-YSB-219-3-3	4.6	3 1/4	21/32	1 1/2	1	4 1/2	3/4	2 1/4	1	1 3/8
15-YSB-219-3-4	5.4	3 13/16	21/32	2	1 3/8	5	7/8	3	1 1/8	2
15-YSB-219-3-5	7.0	4 15/16	29/32	2 1/2	1 3/4	6 1/2	7/8	3 1/8	1 3/4	2 1/8
15-YSB-219-3-6	8.1	5 3/4	11/32	2 1/2	2	7 1/2	1	3 1/2	2	2 3/8

(Includes spacers to allow swivel action up to 7° and to make dimensions interchangeable with standard eye bracket.)
NOTE: To assure precision fit-up, pivot pins, machined to special tolerances are furnished with all swivel eye brackets, unless otherwise specified.



ROD END COUPLER AND WELD PLATE

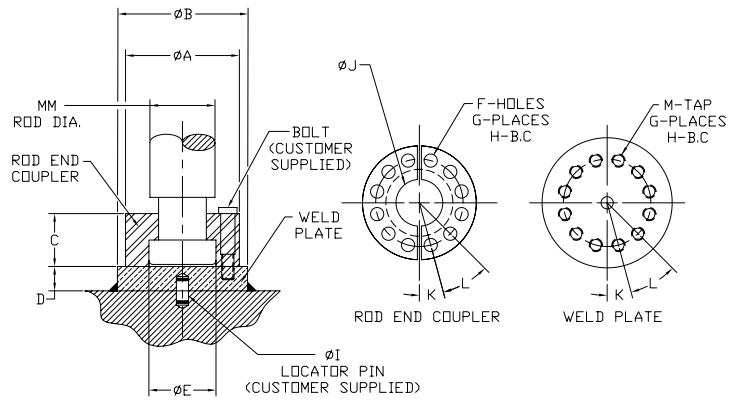

ROD END COUPLER PART#	WELD PLATE PART#	WELD PLATE MATERIAL	MM	A	B	C	D	E	F	G	H	I	J	K	L	M
18-FEC-062	18-FEC-062-WP	CD 1018	5/8	1.500	2.000	.562	.500	.656	.218	4	1.125	.250	.406	45°	90°	10-24
18-FEC-100	18-FEC-100-WP	CD 1018	1	2.000	2.500	.875	.500	1.063	.281	6	1.500	.250	.750	30°	60°	1/4-20
18-FEC-137	18-FEC-137-WP	CD 1018	1 3/8	2.500	3.000	1.000	.625	1.438	.343	6	2.000	.250	.938	30°	60°	5/16-18
18-FEC-175	18-FEC-175-WP	CD 1018	1 3/4	3.000	4.000	1.250	.625	1.813	.343	8	2.375	.250	1.187	22.5°	45°	5/16-18
18-FEC-200	18-FEC-200-WP	CD 1018	2	3.500	4.000	1.625	.750	2.063	.406	12	2.688	.375	1.438	15°	30°	3/8-16
18-FEC-250	18-FEC-250-WP	CD 1018	2 1/2	4.000	4.500	1.875	.750	2.625	.406	12	3.188	.375	1.875	15°	30°	3/8-16
18-FEC-300	18-FEC-300-WP	CD 1018	3	5.000	5.500	2.375	1.000	3.125	.531	12	4.000	.375	2.375	15°	30°	1/2-13
18-FEC-350	18-FEC-350-WP	A 36 HRS	3 1/2	5.875	7.000	2.625	1.000	3.625	.656	12	4.688	.375	2.625	15°	30°	5/8-11
18-FEC-400	18-FEC-400-WP	A 36 HRS	4	6.375	7.000	2.625	1.000	4.125	.656	12	5.188	.375	3.125	15°	30°	5/8-11
18-FEC-450	18-FEC-450-WP	A 36 HRS	4 1/2	6.875	8.000	3.125	1.000	4.625	.656	12	5.688	.375	4.625	15°	30°	5/8-11
18-FEC-500	18-FEC-500-WP	A 36 HRS	5	7.375	8.000	3.125	1.000	5.125	.656	12	6.188	.375	4.000	15°	30°	5/8-11
18-FEC-550	18-FEC-550-WP	A 36 HRS	5 1/2	8.250	9.000	3.875	1.250	5.625	.781	12	6.875	.375	4.500	15°	30°	3/4-10
18-FEC-700	18-FEC-700-WP	A 36 HRS	7	10.375	11.000	4.000	1.750	7.125	1.031	12	8.750	.375	5.938	15°	30°	1"-8

MALE SPHERICAL ROD EYE

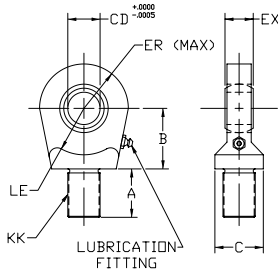

PART NUMBER	CD	KK	A	B	C	ER	EX	LE	MAX LOAD
13-MSRE-0500	.5000	7/16-20	11/16	7/8	7/8	7/8	7/16	3/4	2,600
13-MSRE-0750	.7500	3/4-16	1	1 1/4	1 5/16	1 1/4	21/32	1 1/16	7,080
13-MSRE-1000	1.000	1-14	1 1/2	1 7/8	1 1/2	1 3/8	7/8	1 7/16	12,590
13-MSRE-1375	1.3750	1 1/4-12	2	2 1/8	2	1 13/16	1 3/16	1 7/8	22,930
13-MSRE-1750	1.7500	1 1/2-12	2 1/8	2 1/2	2 1/4	2 3/16	1 17/32	2 1/8	38,220
13-MSRE-2000	2.000	1 7/8-12	2 7/8	2 3/4	2 5/8	2 5/8	1 3/4	2 1/2	50,360

SPHERICAL CLEVIS EYE BRACKET

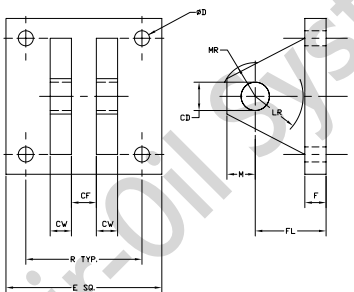

PART NUMBER	CD	CF	CW	D	E	F	FL	M	MR	LR	R
14-YCB-133-03-CBS	.500	.44	.50	.41	.300	.50	.150	.50	.62	.94	.205
14-YCB-133-05-CBS	.750	.66	.62	.53	.375	.62	.200	.88	1.00	1.38	.276
14-YCB-133-06-CBS	1.000	.88	.75	.53	.550	.75	.250	1.00	1.19	1.69	.410
14-YCB-133-08-CBS	1.375	1.19	1.00	.66	.650	.88	.350	1.38	1.62	2.44	.495
14-YCB-133-10-CBS	1.750	1.53	1.25	.91	.850	1.25	.450	1.75	2.06	2.88	.658
14-YCB-133-12-CBS	2.000	1.75	1.50	.91	1.062	1.50	.500	2.00	2.38	3.31	.792

SPHERICAL PINS

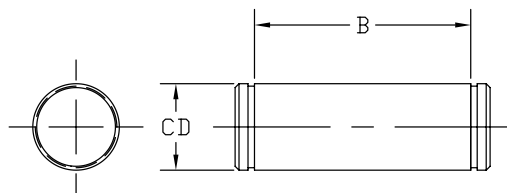

PART NUMBER	CD	B	
12-YP-9003-3-G-CBS	.4997	+0.000 -0.004	1 9/16
12-YP-9004-3-G-CBS	.7497	+0.000 -0.005	2 1/32
12-YP-9006-3-CBS	.9997	+0.000 -0.005	2 1/2
12-YP-9008-3-CBS	1.3746	+0.000 -0.006	3 5/16
12-YP-9010-3-CBS	1.7496	+0.000 -0.006	4 7/32
12-YP-9012-3-CBS	1.9996	+0.000 -0.007	4 15/16

STANDARD ROD END STYLES

ROD END STYLE #	DIMENSIONS	ROD END STYLE #	DIMENSIONS																																																																																								
#2** STANDARD MALE (NFPA-SM)		#4 STANDARD FEMALE (NFPA-SF)																																																																																									
#1 STANDARD MALE (NFPA-IM)		<table border="1"> <thead> <tr> <th rowspan="2">ROD</th> <th colspan="4">ADDITIONAL DIMENSIONS</th> <th rowspan="2">STYLE 8</th> </tr> <tr> <th colspan="4">STYLE 9</th> </tr> <tr> <th>MM</th> <th>AC +0.030</th> <th>AD +0.010</th> <th>AE+0.000/-0.010</th> <th>AF +0.010</th> <th>FT</th> </tr> </thead> <tbody> <tr> <td>5/8</td> <td>1 1/8</td> <td>5/8</td> <td>1/4</td> <td>3/8</td> <td>5/8-18</td> </tr> <tr> <td>1</td> <td>1 1/2</td> <td>15/16</td> <td>3/8</td> <td>11/16</td> <td>1-14</td> </tr> <tr> <td>1 3/8</td> <td>1 3/4</td> <td>1 1/16</td> <td>3/8</td> <td>7/8</td> <td>1 3/8-12</td> </tr> <tr> <td>1 3/4</td> <td>2</td> <td>1 5/16</td> <td>1/2</td> <td>1 1/8</td> <td>1 3/4-12</td> </tr> <tr> <td>2</td> <td>2 5/8</td> <td>1 11/16</td> <td>5/8</td> <td>1 3/8</td> <td>2-12</td> </tr> <tr> <td>2 1/2</td> <td>3 1/4</td> <td>1 15/16</td> <td>3/4</td> <td>1 3/4</td> <td>2 1/2-12</td> </tr> <tr> <td>3</td> <td>3 5/8</td> <td>2 7/16</td> <td>7/8</td> <td>2 1/4</td> <td>3-12</td> </tr> <tr> <td>3 1/2</td> <td>4 3/8</td> <td>2 11/16</td> <td>1</td> <td>2 1/2</td> <td>3 1/2-12</td> </tr> <tr> <td>4</td> <td>4 1/2</td> <td>2 11/16</td> <td>1</td> <td>3</td> <td>4-12</td> </tr> <tr> <td>4 1/2</td> <td>5 1/4</td> <td>3 3/16</td> <td>1 1/2</td> <td>3 1/2</td> <td>4 1/2-12</td> </tr> <tr> <td>5</td> <td>5 3/8</td> <td>3 3/16</td> <td>1 1/2</td> <td>3 7/8</td> <td>5-12</td> </tr> <tr> <td>5 1/2</td> <td>6 1/4</td> <td>3 15/16</td> <td>1 7/8</td> <td>4 3/8</td> <td>5 1/2-12</td> </tr> </tbody> </table>		ROD	ADDITIONAL DIMENSIONS				STYLE 8	STYLE 9				MM	AC +0.030	AD +0.010	AE+0.000/-0.010	AF +0.010	FT	5/8	1 1/8	5/8	1/4	3/8	5/8-18	1	1 1/2	15/16	3/8	11/16	1-14	1 3/8	1 3/4	1 1/16	3/8	7/8	1 3/8-12	1 3/4	2	1 5/16	1/2	1 1/8	1 3/4-12	2	2 5/8	1 11/16	5/8	1 3/8	2-12	2 1/2	3 1/4	1 15/16	3/4	1 3/4	2 1/2-12	3	3 5/8	2 7/16	7/8	2 1/4	3-12	3 1/2	4 3/8	2 11/16	1	2 1/2	3 1/2-12	4	4 1/2	2 11/16	1	3	4-12	4 1/2	5 1/4	3 3/16	1 1/2	3 1/2	4 1/2-12	5	5 3/8	3 3/16	1 1/2	3 7/8	5-12	5 1/2	6 1/4	3 15/16	1 7/8	4 3/8	5 1/2-12
ROD	ADDITIONAL DIMENSIONS				STYLE 8																																																																																						
	STYLE 9																																																																																										
MM	AC +0.030	AD +0.010	AE+0.000/-0.010	AF +0.010	FT																																																																																						
5/8	1 1/8	5/8	1/4	3/8	5/8-18																																																																																						
1	1 1/2	15/16	3/8	11/16	1-14																																																																																						
1 3/8	1 3/4	1 1/16	3/8	7/8	1 3/8-12																																																																																						
1 3/4	2	1 5/16	1/2	1 1/8	1 3/4-12																																																																																						
2	2 5/8	1 11/16	5/8	1 3/8	2-12																																																																																						
2 1/2	3 1/4	1 15/16	3/4	1 3/4	2 1/2-12																																																																																						
3	3 5/8	2 7/16	7/8	2 1/4	3-12																																																																																						
3 1/2	4 3/8	2 11/16	1	2 1/2	3 1/2-12																																																																																						
4	4 1/2	2 11/16	1	3	4-12																																																																																						
4 1/2	5 1/4	3 3/16	1 1/2	3 1/2	4 1/2-12																																																																																						
5	5 3/8	3 3/16	1 1/2	3 7/8	5-12																																																																																						
5 1/2	6 1/4	3 15/16	1 7/8	4 3/8	5 1/2-12																																																																																						

OPTIONAL ROD END STYLES

ROD END STYLE #	DIMENSIONS	ROD END STYLE #	DIMENSIONS
#5		#3 (NFPA-LF)	
#6		#7 (NFPA-PL)	
#9		#8 (NFPA-FM)	

**** MALE ROD END STYLE #2 WILL BE FURNISHED UNLESS OTHERWISE SPECIFIED**

(4) SPANNER HOLES USED INSTEAD OF FLATS ON 4" DIA. AND LARGER.

NOTE: CONSULT FACTORY FOR ROD END CONFIGURATIONS OTHER THAN THOSE SHOWN.

NOTE: ALL YATES MOUNTING ACCESSORIES ARE DESIGNED TO FIT #2 ROD END STYLES



ALUMINUM

Series A2/H2

AIR SERVICE/ LIGHT DUTY HYDRAULIC



A2 FEATURES

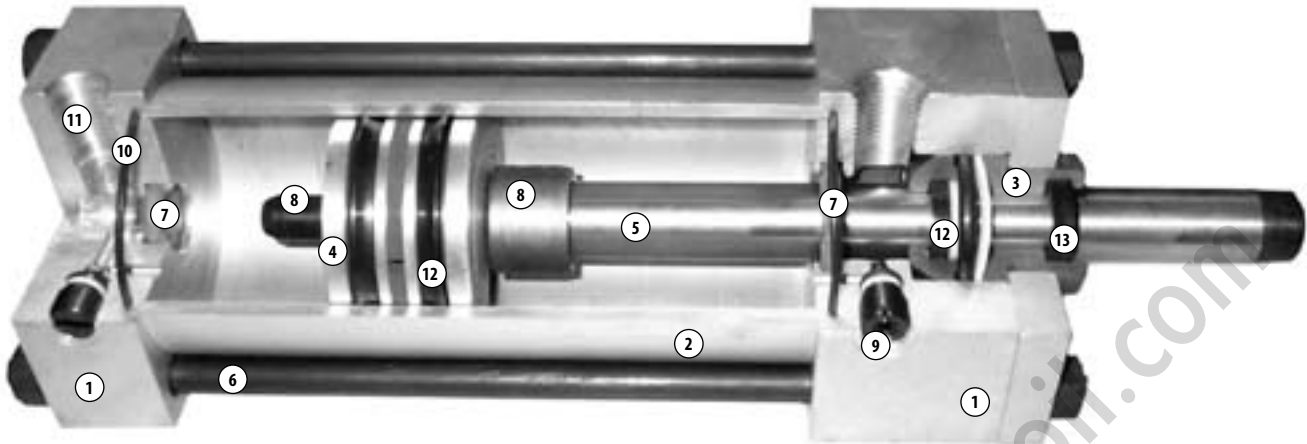

- 1. HEAD/CAP-** Precision machined from solid aluminum alloy bar stock (6061-T6).
- 2. CYLINDER BARREL-** Clear anodized aluminum alloy tubing with file hard coat I.D., provides superior seal life and excellent abrasion resistance. Tube ends are piloted into head and cap for positive cylinder alignment and concentricity.
- 3. ROD CARTRIDGE-** Extra long high strength bronze gland provides maximum bearing support and wear resistance. With certain exceptions, a removable retainer allows for gland removal without cylinder disassembly.
- 4. PISTON-** Light weight, high strength, precision machined from solid aluminum alloy. Magnetic ring for switch actuation is optional.
- 5. PISTON ROD-** High strength steel piston rod has a ground, polished and hard chrome plated surface for extended bearing and seal life.
- 6. TIE RODS-** High strength steel, roll threaded for added strength and engagement.
- 7. CUSHION SEALS-** State of the art self-aligning, self-checking elastomeric cushion seals ensures quick break away. Eliminates the need for ball checks and provides optimum cushioning.

- 8. CUSHIONS-** Cap cushion spear and floating head cushion bushing provide consistent cushioning performance.
- 9. CUSHION ADJUSTMENTS-** Flush mounted captive cushion adjustment allows safe cushion adjustment under pressure. Cushion needle design provides a wide range of cushion adjustment.
- 10. TUBE END SEALS-** (O-ring) compression type seals available in many different compounds. Seals are re-usable if performing maintenance or repair.
- 11. PORTS-** NPT ports are standard. SAE ports are optional.
- 12. PISTON AND ROD SEALS-** The Carboxylated nitrile "U" cups with Teflon[®] compound ensures long seal life and low friction in lubricated and non-lubricated applications.
- 13. ROD WIPER-** Double lip Carboxylated nitrile with Teflon[®] compound acts as secondary seal while keeping dirt, dust and other contaminants out.

A2 MOUNTING STYLES

SIDE MOUNTS

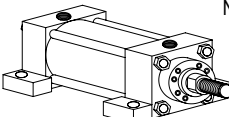
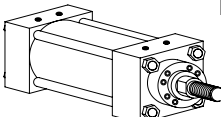
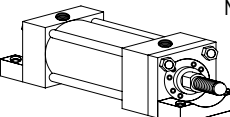
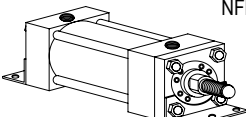
<p>STYLE A PAGE 84 NFPA-MS2</p>  <p>SIDE LUGS 1 1/2-8" BORE</p>	<p>STYLE B PAGE 84 NFPA-MS4</p>  <p>SIDE TAPPED 1 1/2-8" BORE</p>	<p>STYLE E PAGE 86 NFPA-MS7</p>  <p>SIDE END LUGS 1 1/2-8" BORE</p>	<p>STYLE Y PAGE 88 NFPA-MS1</p>  <p>SIDE ANGLE MOUNT 1 1/2-8" BORE</p>
--	--	---	---

END MOUNTS

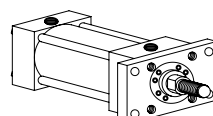
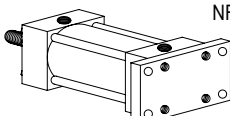
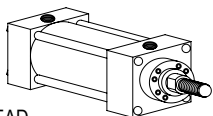
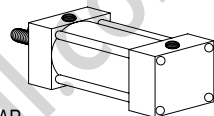
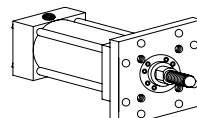
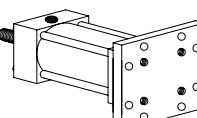
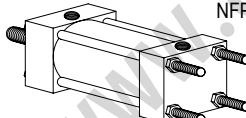
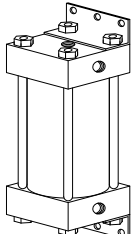
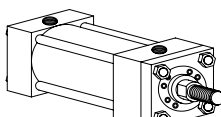
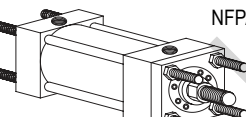
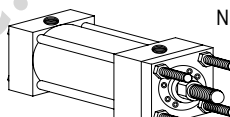
<p>STYLE F PAGE 94 NFPA-MF1</p>  <p>HEAD RECTANGULAR FLANGE 1 1/2-6" BORE</p>	<p>STYLE R PAGE 94 NFPA-MF2</p>  <p>CAP RECTANGULAR FLANGE 1 1/2-6" BORE</p>	<p>STYLE X PAGE 96 NFPA-ME3</p>  <p>HEAD SQUARE INTEGRAL FLANGE 8" BORE</p>	<p>STYLE Z PAGE 96 NFPA-ME4</p>  <p>CAP SQUARE INTEGRAL FLANGE 8" BORE</p>
<p>STYLE J PAGE 94 NFPA-MF5</p>  <p>HEAD SQUARE FLANGE 1 1/2-6" BORE</p>	<p>STYLE S PAGE 94 NFPA-MF6</p>  <p>CAP SQUARE FLANGE 1 1/2-6" BORE</p>	<p>STYLE N PAGE 98 NFPA-MX2</p>  <p>CAP TIE RODS EXTENDED 1 1/2-8" BORE</p>	<p>STYLE YAT PAGE 116 AIR/OIL TANKS</p>  <p>3 1/4-8" BORES YATES "Y" MOUNT STD. (OTHER MOUNTINGS AVAILABLE UPON REQUEST)</p>
<p>STYLE K PAGE 98 NFPA-MX0</p>  <p>NO TIE RODS EXTENDED 1 1/2-8" BORE</p>	<p>STYLE L PAGE 98 NFPA-MX1</p>  <p>BOTH ENDS TIE RODS EXTENDED 1 1/2-8" BORE</p>	<p>STYLE M PAGE 98 NFPA-MX3</p>  <p>HEAD TIE RODS EXTENDED 1 1/2-8" BORE</p>	

PIVOT MOUNTS – CLEVIS AND EYE

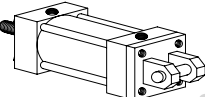
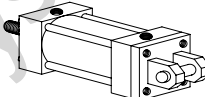
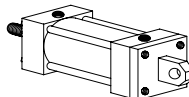
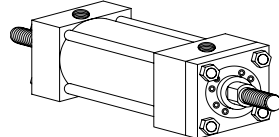
<p>STYLE C PAGE 90 NFPA-MP1</p>  <p>CAP CLEVIS (DETACHABLE) 1 1/2-6" BORE</p>	<p>STYLE DC PAGE 90 NFPA-MP2</p>  <p>CAP DETACHABLE CLEVIS 1 1/2-6" BORE</p>	<p>STYLE DV PAGE 90 NFPA-MP4</p>  <p>CAP DETACHABLE EYE 1 1/2-6" BORE</p>	<p>PAGE 100</p> <p>DOUBLE ROD END (ADD "D" AFTER STYLE)</p>  <p>AVAILABLE IN MOUNTING STYLES A, B, E, F, J, K, L, M, T, U, X, AND Y</p> <p>1 1/2-8" BORE</p>
--	---	---	--

PIVOT MOUNTS – TRUNNION

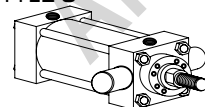
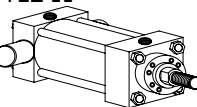
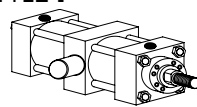
<p>STYLE U PAGE 92 NFPA-MT1</p>  <p>HEAD TRUNNION 1 1/2-8" BORE</p>	<p>STYLE W PAGE 92 NFPA-MT2</p>  <p>CAP TRUNNION 1 1/2-8" BORE</p>	<p>STYLE T PAGE 92 NFPA-MT4</p>  <p>INTERMEDIATE FIXED TRUNNION 1 1/2-8" BORE</p>
--	---	---

YATES AIR AND HYDRAULIC CYLINDERS ARE DESIGNED TO ACCEPT YATES STANDARD MOUNTING ACCESSORIES. SEE PAGE 102 FOR ACCESSORY INFORMATION.



YATES A2/H2 SPECIFICATIONS

PRESSURE RATING: A2 Air Service to 250 PSI
H2 – Non-cushioned, 400 PSI Hydraulic
H2 – Cushioned, 250 PSI Hydraulic (non-stock)

BORE SIZES: 1 1/2" bore through 8" bore

MOUNTING STYLES: 20 different styles
All N.F.P.A interchangeable

TEMPERATURE: -40°F to 200°F standard

RETAINER INFORMATION

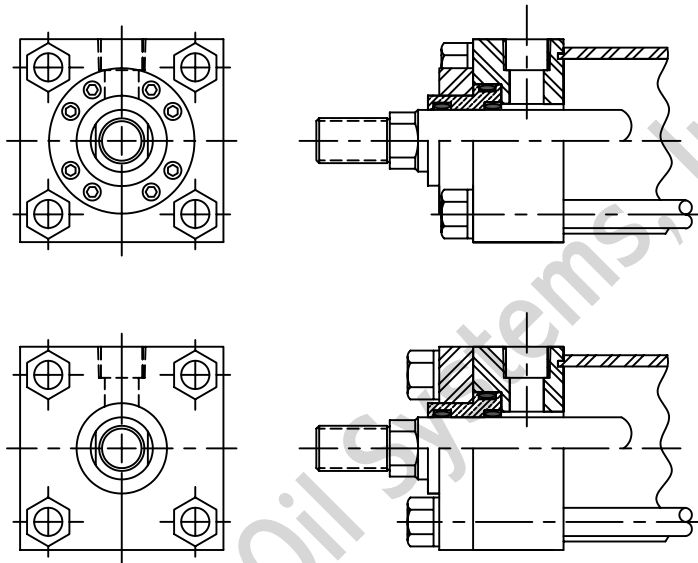

Cylinders with the following bore and rod combinations use circular retainers which permit removal of rod cartridge without disassembling cylinder.

- 2 1/2 bore with 5/8 and 1" rods
- 3 1/4 bore with 1" and 1 3/8 rods
- 4 bore with 1, 1 3/8 rods
- 5 bore with 1, 1 3/8 rods
- 6 bore with 1 3/8, 1 3/4 rods
- 8 bore with 1 3/8 and 1 3/4 rods

Cylinders with the following bore and rod combinations use full plate retainer construction.

- 1 1/2 bore with 5/8 and 1 rods
- 2 bore with 5/8, and 1 rods

HOW TO ORDER A2/H2 CYLINDERS

Feature	Description	Page #	Symbol	A	2	-	A	D	B	3	.	2	B	3	5	.	2	5	N	1	.	3	8	B	2	S	1	1
Series	Aluminum air service		A2	←																								
	Aluminum Hydraulic service		H2																									
Mounting Style	Side lugs (MS2)	84	A																									
	Side tapped (MS4)	84	B																									
	Side end lugs (MS7)	86	E																									
	Center-line lugs (MS3)	88	Y																									
	Head rectangular flange (MF1)	94	F																									
	Cap rectangular flange (MF2)	94	R																									
	Head square flange (MF5)	94	J																									
	Cap square flange (MF6)	94	S																									
	Head square integral flange (ME3)	96	X																									
	Cap square integral flange (ME4)	96	Z																									
	No tie rods extended (MX0)	98	K																									
	Both ends tie rods extended (MX1)	98	L																									
	Head tie rods extended (MX3)	98	M																									
	Cap tie rods extended (MX2)	98	N																									
	Cap clevis (MP1)	90	C																									
	Cap detachable clevis (MP2)	90	DC																									
	Cap detachable eye (MP4)	90	DV																									
	Head trunnion (MT1)	92	U																									
	Cap trunnion (MT2)	92	W																									
	Intermediate fixed trunnion (MT4)	92	T																									
Double Rod	Double rod design if needed		D																									
Cushions	No cushions		N																									
	Cushion head end only		R																									
	Cushion cap end only		C																									
	Cushioned both ends		B																									
Bore size	Specify in inches																											
Piston seals	Carboxilated Nitrile- Standard		B																									
	Nitrile U-cups		N																									
	Poly seals		P																									
	Viton® seals		V																									
	Fluorocarbon poly seals		F																									
	Other (Specify)		X																									
Stroke	Specify in inches with 2 place decimal																											
Ports	NPTF		N																									
	SAE		S																									
	Other (Specify)		X																									
Rod dia.	Specify in inches																											
Rod Seals	Carboxilated Nitrile- Standard		B																									
	Nitrile		N																									
	Poly seals		P																									
	Viton® seals		V																									
	Fluorocarbon poly seals		F																									
Rod End	Standard male		2																									
	Standard female		4																									
	Intermediate male		1																									
	Long female		3																									
	Extended standard male		5																									
	Extended intermediate male		6																									
	Plain rod end		7																									
	Male full thread		8																									
	Male rod coupling		9																									
	Special male (specify)		M																									
	Special female (specify)		F																									
	Special stud (specify)		S																									
	Special other (specify)																											
Specials Specify	Magnetic Piston		S																									
	Stop tube																											
	Reed/ Hall Effect Switches																											
	Non-standard mount																											
	Stainless steel rod																											
	Extra rod extension																											
	Many more options available																											
Head port	specify location 1-4		1-4																									
Cap port	specify location 1-5		1-5																									



SIDE LUGS MOUNT

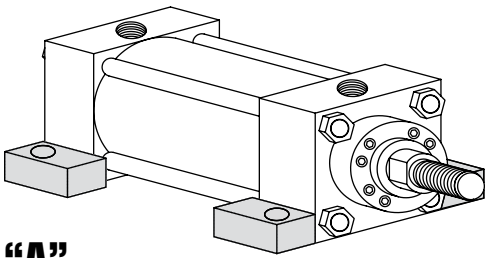

"A"

YATES STYLE A
NFPA-MS2

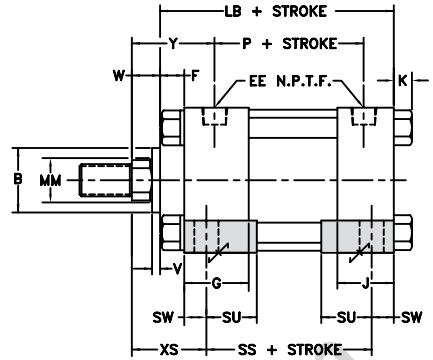
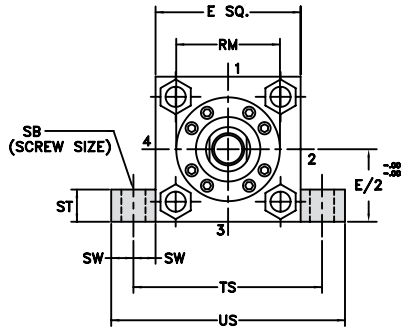

SIDE TAPPED MOUNT

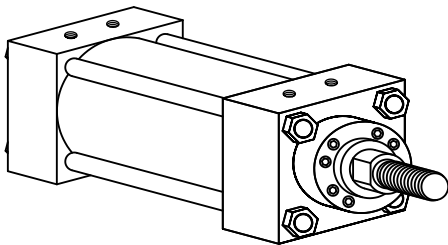

"B"

YATES STYLE B
NFPA-MS4

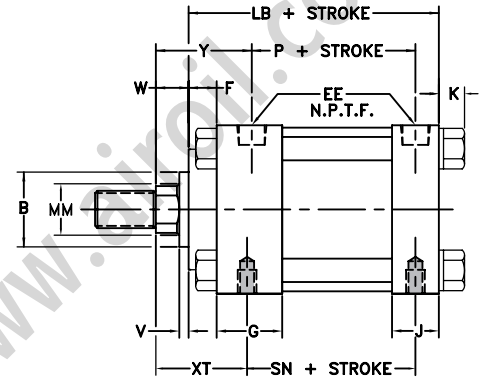
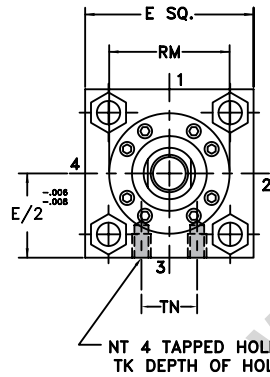

Air-Oil Systems, Inc.

STANDARD ROD ENDS

#2 STD MALE NFPA-SM

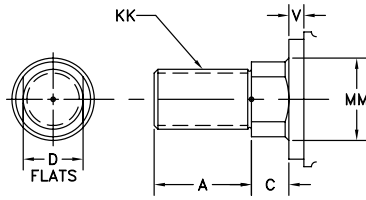

#4 STD FEMALE NFPA-SF

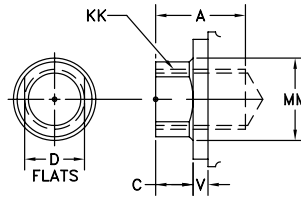

#1 MALE NFPA-IM

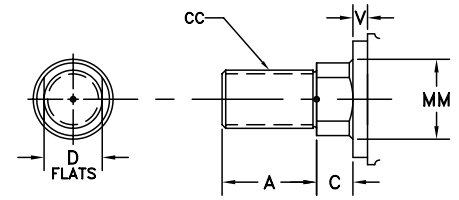

BORE																ADD STROKE			
	E	EE	F	G	J	K	SB	ST	SU	SW	TS	US	NT	TK	TN	LB	P	SS *	SN
1 1/2	2	3/8	3/8	1 1/2	1	1/4	3/8	1/2	15/16	3/8	2 3/4	3 1/2	1/4-20	3/8	5/8	4	2 1/4	2 7/8	2 1/4
2	2 1/2	3/8	3/8	1 1/2	1	5/16	3/8	1/2	15/16	3/8	3 1/4	4	5/16-18	1/2	7/8	4	2 1/4	2 7/8	2 1/4
2 1/2	3	3/8	3/8	1 1/2	1	5/16	3/8	1/2	15/16	3/8	3 3/4	4 1/2	3/8-16	5/8	1 1/4	4 1/8	2 3/8	3	2 3/8
3 1/4	3 3/4	1/2	5/8	1 3/4	1 1/4	3/8	1/2	3/4	1 1/4	1/2	4 3/4	5 3/4	1/2-13	3/4	1 1/2	4 7/8	2 5/8	3 1/4	2 5/8
4	4 1/2	1/2	5/8	1 3/4	1 1/4	3/8	1/2	3/4	1 1/4	1/2	5 1/2	6 1/2	1/2-13	3/4	2 1/16	4 7/8	2 5/8	3 1/4	2 5/8
5	5 1/2	1/2	5/8	1 3/4	1 1/4	7/16	3/4	1	1 9/16	11/16	6 7/8	8 1/4	5/8-11	1	2 11/16	5 1/8	2 7/8	3 1/8	2 7/8
6	6 1/2	3/4	3/4	2	1 1/2	7/16	3/4	1	1 9/16	11/16	7 7/8	9 1/4	3/4-10	1 1/8	3 1/4	5 3/4	3 1/8	3 5/8	3 1/8
8	8 1/2	3/4	3/4	2	1 1/2	9/16	3/4	1	1 9/16	11/16	9 7/8	11 1/4	3/4-10	1 1/8	4 1/2	5 7/8	3 1/4	3 3/4	3 1/4

BORE	ROD DIA. MM	THREAD		ROD EXTENSIONS AND PILOT DIMENSIONS								ENVELOPE AND MOUNTING DIMENSIONS		
		KK	CC	A	B ±	C	D	V	W	RM	XS	XT	Y	
1 1/2	5/8	7/16-20	1/2-20	3/4	1 1/8	3/8	1/2	1/4	5/8	§	1 3/8	1 15/16	1 29/32	
	1†•Φ	3/4-16	7/8-14	1 1/8	1 1/2	1/2	7/8	1/2	1	§	1 3/4	2 5/16	2 9/32	
2	5/8	7/16-20	1/2-20	3/4	1 1/8	3/8	1/2	1/4	5/8	§	1 3/8	1 15/16	1 29/32	
	1	3/4-16	7/8-14	1 1/8	1 1/2	1/2	7/8	1/2	1	§	1 3/4	2 5/16	2 9/32	
2 1/2	5/8	7/16-20	1/2-20	3/4	1 1/8	3/8	1/2	1/4	5/8	2 3/8	1 3/8	1 15/16	1 29/32	
	1	3/4-16	7/8-14	1 1/8	1 1/2	1/2	7/8	1/2	1	2 5/8	1 3/4	2 5/16	2 9/32	
3 1/4	1	3/4-16	7/8-14	1 1/8	1 1/2	1/2	7/8	1/4	3/4	2 5/8	1 7/8	2 7/16	2 7/16	
	1 3/8	1-14	1 1/4-12	1 5/8	2	5/8	1 1/8	3/8	1	3 7/32	2 1/8	2 11/16	2 11/16	
4	1	3/4-16	7/8-14	1 1/8	1 1/2	1/2	7/8	1/4	3/4	2 5/8	1 7/8	2 7/16	2 7/16	
	1 3/8	1-14	1 1/4-12	1 5/8	2	5/8	1 1/8	3/8	1	3 7/32	2 1/8	2 11/16	2 11/16	
5	1	3/4-16	7/8-14	1 1/8	1 1/2	1/2	7/8	1/4	3/4	2 5/8	2 1/16	2 7/16	2 7/16	
	1 3/8	1-14	1 1/4-12	1 5/8	2	5/8	1 1/8	3/8	1	3 7/32	2 5/16	2 11/16	2 11/16	
6	1 3/8	1-14	1 1/4-12	1 5/8	2	5/8	1 1/8	1/4	7/8	3 7/32	2 5/16	2 13/16	2 13/16	
	1 3/4	1 1/4-12	1 1/2-12	2	2 3/8	3/4	1 1/2	3/8	1 1/8	3 7/8	2 9/16	3 1/16	3 1/16	
8	1 3/8	1-14	1 1/4-12	1 5/8	2	5/8	1 1/8	1/4	7/8	3 7/32	2 5/16	2 13/16	2 13/16	
	1 3/4	1 1/4-12	1 1/2-12	2	2 3/8	3/4	1 1/2	3/8	1 1/8	3 7/8	2 9/16	3 1/16	3 1/16	

† HEAD END PORT SHALLOW TAPPED
 • CUSHION NOT AVAILABLE ON HEAD END
 ‡ B DIMENSION TOLERANCE -.001/- .003
 § THESE CYLINDERS HAVE FULL PLATE RETAINERS. USE "E" DIMENSION INSTEAD OF "RM" - SEE PAGE 82
 * ON DOUBLE ROD CYLINDERS "SS" DIMENSION CHANGES, SEE PAGE 100
 Φ "B" MOUNT NOT AVAILABLE WITH STANDARD MOUNTING DIMENSIONS, CONSULT FACTORY



SIDE END LUGS MOUNT

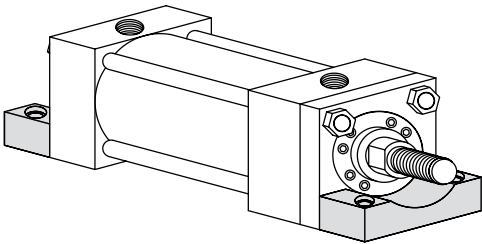

“E”
YATES STYLE E
 NFPA-MS7

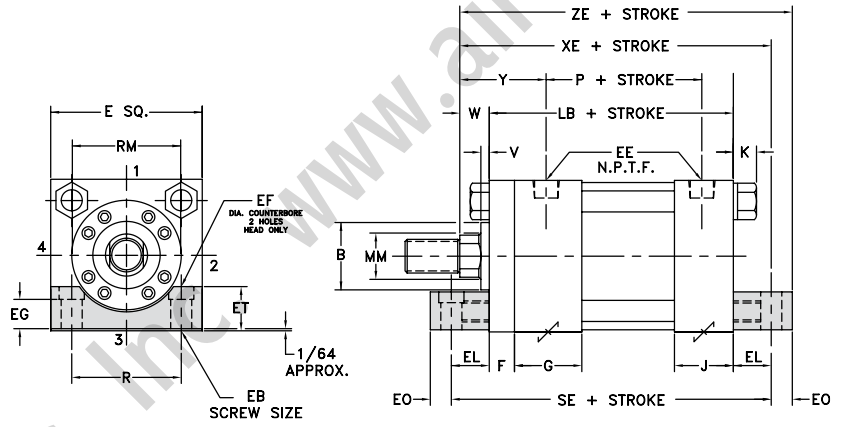

STANDARD ROD ENDS

#2 STD MALE NFPA-SM

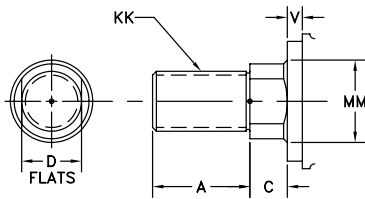

#4 STD FEMALE NFPA-SF

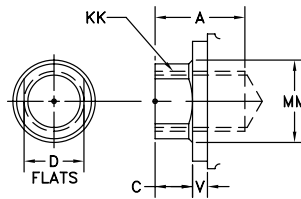

#1 MALE NFPA-IM

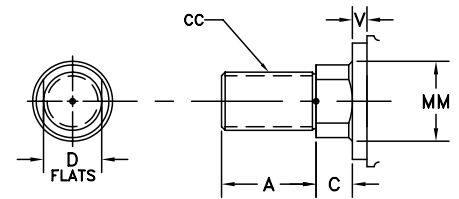

BORE	E	EE	F	G	J	K	EB	EF	EG	EL	EO	ET	R	LB	ADD STROKE	
															SE*	P
1 1/2	2	3/8	3/8	1 1/2	1	1/4	1/4	1/2	7/16	3/4	1/4	9/16	1.43	4	5 1/2	2 1/4
2	2 1/2	3/8	3/8	1 1/2	1	5/16	5/16	1/2	15/32	15/16	5/16	3/4	1.84	4	5 7/8	2 1/4
2 1/2	3	3/8	3/8	1 1/2	1	5/16	5/16	1/2	5/8	1 1/16	5/16	7/8	2.19	4 1/8	6 1/4	2 3/8
3 1/4	3 3/4	1/2	5/8	1 3/4	1 1/4	3/8	3/8	NA	NA	7/8	3/8	1	2.76	4 7/8	6 5/8	2 5/8
4	4 1/2	1/2	5/8	1 3/4	1 1/4	3/8	3/8	NA	NA	1	3/8	1 1/4	3.32	4 7/8	6 7/8	2 5/8
5	5 1/2	1/2	5/8	1 3/4	1 1/4	7/16	1/2	7/8	1 1/4	1 1/16	1/2	1 1/2	4.10	5 1/8	7 1/4	2 7/8
6	6 1/2	3/4	3/4	2	1 1/2	7/16	1/2	7/8	1 1/4	1	1/2	1 5/8	4.88	5 3/4	7 3/4	3 1/8
8	8 1/2	3/4	3/4	2	1 1/2	9/16	5/8	NA	NA	1 1/8	5/8	2	6.44	5 7/8	7 3/8	3 1/4

BORE	ROD DIA.	ROD EXTENSIONS AND PILOT DIMENSIONS											ADD STROKE	
	MM	KK	CC	A	B	C	D	V	W	RM	Y	XE*	ZE*	
1 1/2	5/8	7/16-20	1/2-20	3/4	1 1/8	3/8	1/2	1/4	5/8	§	1 29/32	5 3/8	5 5/8	
	1 †Ω	3/4-16	7/8-14	1 1/8	1 1/2	1/2	7/8	1/2	1	§	2 9/32	5 3/4	6	
2	5/8	7/16-20	1/2-20	3/4	1 1/8	3/8	1/2	1/4	5/8	§	1 29/32	5 9/16	5 7/8	
	1	3/4-16	7/8-14	1 1/8	1 1/2	1/2	7/8	1/2	1	§	2 9/32	5 15/16	6 1/4	
2 1/2	5/8	7/16-20	1/2-20	3/4	1 1/8	3/8	1/2	1/4	5/8	2 3/8	1 29/32	5 13/16	6 1/8	
	1	3/4-16	7/8-14	1 1/8	1 1/2	1/2	7/8	1/2	1	2 5/8	2 9/32	6 3/16	6 1/2	
3 1/4	1	3/4-16	7/8-14	1 1/8	1 1/2	1/2	7/8	1/4	3/4	2 5/8	2 7/16	6 1/2	6 7/8	
	1 3/8	1-14	1 1/4-12	1 5/8	2	5/8	1 1/8	3/8	1	3 7/32	2 11/16	6 3/4	7 1/8	
4	1	3/4-16	7/8-14	1 1/8	1 1/2	1/2	7/8	1/4	3/4	2 5/8	2 7/16	6 5/8	7	
	1 3/8	1-14	1 1/4-12	1 5/8	2	5/8	1 1/8	3/8	1	3 7/32	2 11/16	6 7/8	7 1/4	
5	1	3/4-16	7/8-14	1 1/8	1 1/2	1/2	7/8	1/4	3/4	2 5/8	2 7/16	6 15/16	7 7/16	
	1 3/8	1-14	1 1/4-12	1 5/8	2	5/8	1 1/8	3/8	1	3 7/32	2 11/16	7 3/16	7 11/16	
6	1 3/8	1-14	1 1/4-12	1 5/8	2	5/8	1 1/8	1/4	7/8	3 7/32	2 13/16	7 5/8	8 1/8	
	1 3/4	1 1/4-12	1 1/2-12	2	2 3/8	3/4	1 1/2	3/8	1 1/8	3 7/8	3 1/16	7 7/8	8 3/8	
8	1 3/8	1-14	1 1/4-12	1 5/8	2	5/8	1 1/8	1/4	7/8	3 7/32	2 13/16	7 7/8	8 1/2	
	1 3/4	1 1/4-12	1 1/2-12	2	2 3/8	3/4	1 1/2	3/8	1 1/8	3 7/8	3 1/16	8 1/8	8 3/4	

† HEAD END PORTS SHALLOW TAPPED
 Ω CUSHION NOT AVAILABLE ON HEAD END
 § THESE CYLINDERS HAVE FULL PLATE RETAINERS. USE "E" DIMENSION INSTEAD OF "RM" - SEE PAGE 82
 ‡ B DIMENSION TOLERANCE -.001/ -.003
 * SE, XE & ZE DIMENSION CHANGES ON DOUBLE ROD CYLINDERS, SEE PAGE 100 FOR DETAILS



SIDE END ANGLE MOUNT

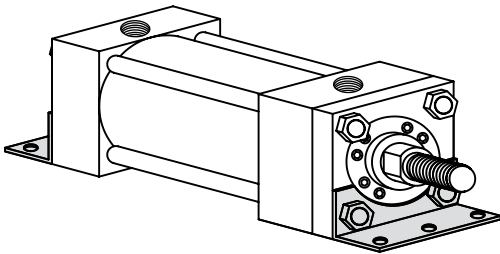

“V”
YATES STYLE V
 NFPA-MS1

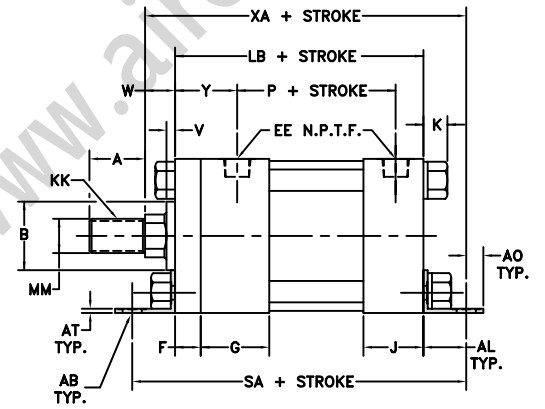
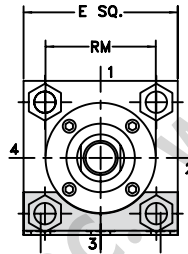

STANDARD ROD ENDS

#2 STD MALE NFPA-SM

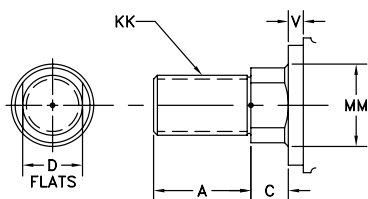

#4 STD FEMALE NFPA-SF

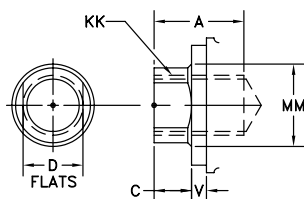

#1 MALE NFPA-IM

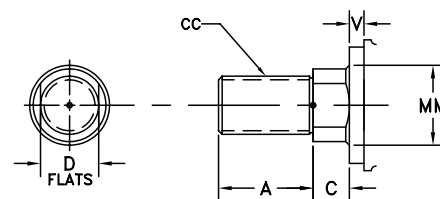

BORE													ADD STROKE		
	E	EE	F	G	J	K	S	AB	AH	AL	AO	AT	LB	SA	P
1 1/2	2	3/8	3/8	1 1/2	1	1/4	1 1/4	3/8	1 3/16	1	3/8	1/8	4	6	2 1/4
2	2 1/2	3/8	3/8	1 1/2	1	5/16	1 3/4	3/8	1 7/16	1	3/8	1/8	4	6	2 1/4
2 1/2	3	3/8	3/8	1 1/2	1	5/16	2 1/4	3/8	1 5/8	1	3/8	1/8	4 1/8	6 1/8	2 3/8
3 1/4	3 3/4	1/2	5/8	1 3/4	1 1/4	3/8	2 3/4	1/2	1 15/16	1 1/4	1/2	1/8	4 7/8	7 3/8	2 3/8
4	4 1/2	1/2	5/8	1 3/4	1 1/4	3/8	3 1/2	1/2	2 1/4	1 1/4	1/2	1/8	4 7/8	7 3/8	2 5/8
5	5 1/2	1/2	5/8	1 3/4	1 1/4	7/16	4 1/4	5/8	2 3/4	1 3/8	5/8	3/16	5 1/8	7 7/8	2 7/8
6	6 1/2	3/4	3/4	2	1 1/2	7/16	5 1/4	3/4	3 1/4	1 3/8	5/8	1/4	5 3/4	8 1/2	3 1/8
8	8 1/2	3/4	3/4	2	1 1/2	9/16	7 1/8	3/4	4 1/4	1 13/16	11/16	1/4	5 7/8	8 3/4	3 1/4

BORE	ROD DIA.	ROD EXTENSIONS AND PILOT DIMENSIONS										ADD STROKE	
	MM	KK	CC	A	B †	C	D	V	W	RM	Y	XA	
1 1/2	5/8	7/16-20	1/2-20	3/4	1 1/8	3/8	1/2	1/4	5/8	§	1 29/32	5 5/8	
	1 †Ω	3/4-16	7/8-14	1 1/8	1 1/2	1/2	7/8	1/2	1	§	2 9/32	6	
2	5/8	7/16-20	1/2-20	3/4	1 1/8	3/8	1/2	1/4	5/8	§	1 29/32	5 5/8	
	1	3/4-16	7/8-14	1 1/8	1 1/2	1/2	7/8	1/2	1	§	2 9/32	6	
2 1/2	5/8	7/16-20	1/2-20	3/4	1 1/8	3/8	1/2	1/4	5/8	2 3/8	1 29/32	5 3/4	
	1	3/4-16	7/8-14	1 1/8	1 1/2	1/2	7/8	1/2	1	2 5/8	2 9/32	6 1/8	
3 1/4	1	3/4-16	7/8-14	1 1/8	1 1/2	1/2	7/8	1/4	3/4	2 3/8	2 7/16	6 7/8	
	1 3/8	1-14	1 1/4-12	1 5/8	2	5/8	1 1/8	3/8	1	2 5/8	2 11/16	7 1/8	
4	1	3/4-16	7/8-14	1 1/8	1 1/2	1/2	7/8	1/4	3/4	2 5/8	2 7/16	6 7/8	
	1 3/8	1-14	1 1/4-12	1 5/8	2	5/8	1 1/8	3/8	1	3 7/32	2 11/16	7 1/8	
5	1	3/4-16	7/8-14	1 1/8	1 1/2	1/2	7/8	1/4	3/4	2 5/8	2 7/16	7 1/4	
	1 3/8	1-14	1 1/4-12	1 5/8	2	5/8	1 1/8	3/8	1	3 7/32	2 11/16	7 1/2	
6	1 3/8	1-14	1 1/4-12	1 5/8	2	5/8	1 1/8	1/4	7/8	3 7/32	2 13/16	8	
	1 3/4	1 1/4-12	1 1/2-12	2	2 3/8	3/4	1 1/2	3/8	1 1/8	3 7/8	3 1/16	8 1/4	
8	1 3/8	1-14	1 1/4-12	1 5/8	2	5/8	1 1/8	1/4	7/8	3 7/32	2 13/16	8 9/16	
	1 3/4	1 1/4-12	1 1/2-12	2	2 3/8	3/4	1 1/2	3/8	1 1/8	3 7/8	3 1/16	8 13/16	

† HEAD END PORTS SHALLOW TAPPED
 Ω CUSHION NOT AVAILABLE ON HEAD END
 § THESE CYLINDERS HAVE FULL PLATE RETAINERS. USE "E" DIMENSION INSTEAD OF "RM" - SEE PAGE 82
 ‡ B DIMENSION TOLERANCE -.001/ -.003



CAP CLEVIS MOUNT (DETACHABLE)

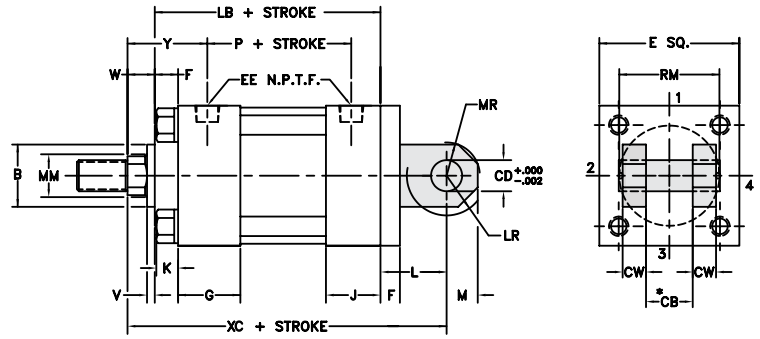
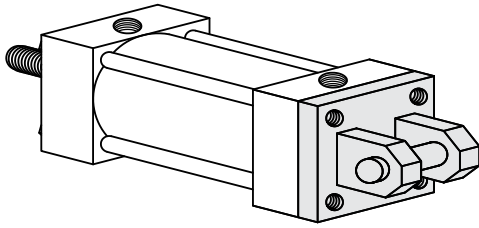

“C”

YATES STYLE C
NFPA-MP1

CAP DETACHABLE CLEVIS MOUNT

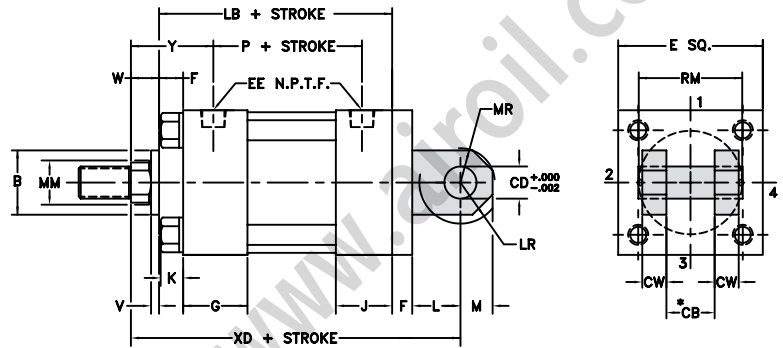
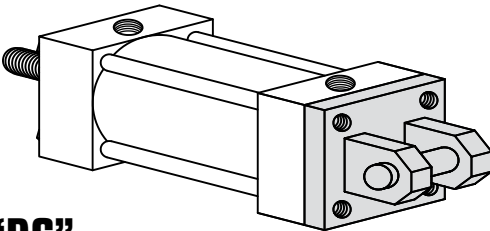

“DC”

YATES STYLE DC
NFPA-MP2

CAP DETACHABLE EYE MOUNT

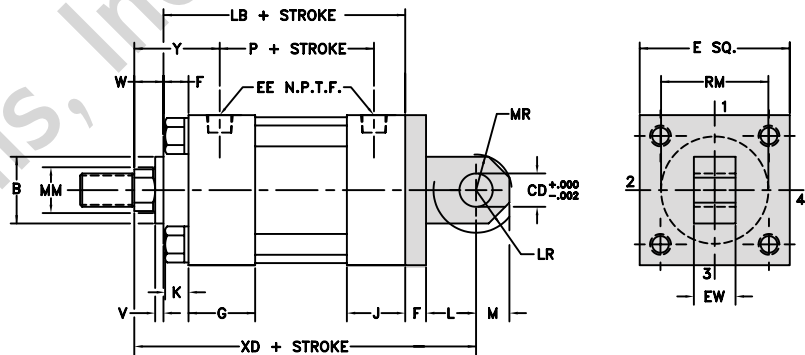
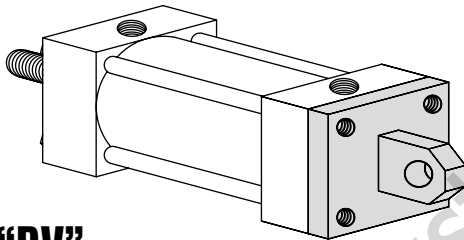

“DV”

YATES STYLE DV
NFPA-MP4

STANDARD ROD ENDS

#2 STD MALE NFPA-SM

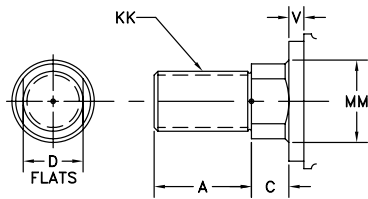

#4 STD FEMALE NFPA-SF

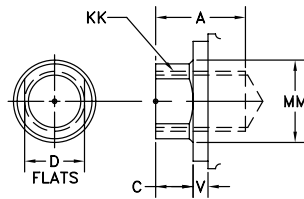

#1 MALE NFPA-IM

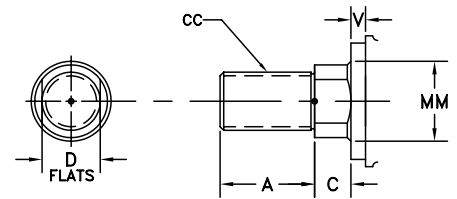

BORE	E	EE	F	G	J	K	CBΦ Φ	CD	CW	EW ■	L	LR	MR	ADD STROKE	
														LB	P
1 1/2	2	3/8	3/8	1 1/2	1	1/4	3/4	1/2	1/2	3/4	3/4	9/16	5/8	4	2 1/4
2	2 1/2	3/8	3/8	1 1/2	1	5/16	3/4	1/2	1/2	3/4	3/4	9/16	5/8	4	2 1/4
2 1/2	3	3/8	3/8	1 1/2	1	5/16	3/4	1/2	1/2	3/4	3/4	9/16	5/8	4 1/8	2 3/8
3 1/4	3 3/4	1/2	5/8	1 3/4	1 1/4	3/8	1 1/4	3/4	5/8	1 1/4	1 1/4	1 1/16	7/8	4 7/8	2 5/8
4	4 1/2	1/2	5/8	1 3/4	1 1/4	3/8	1 1/4	3/4	5/8	1 1/4	1 1/4	1 1/16	7/8	4 7/8	2 5/8
5	5 1/2	1/2	5/8	1 3/4	1 1/4	7/16	1 1/4	3/4	5/8	1 1/4	1 1/4	1 1/16	7/8	5 1/8	2 7/8
6	6 1/2	3/4	3/4	2	1 1/2	7/16	1 1/2	1	3/4	1 1/2	1 1/2	1 5/16	1 1/4	5 3/4	3 1/8

BORE	ROD DIA.		THREAD		ROD EXTENSIONS AND PILOT DIMENSIONS								ADD STROKE	
	MM	KK	CC		A	B †	C	D	V	W	Y	RM	XD	XC
1 1/2	5/8	7/16-20	1/2-20		3/4	1 1/8	3/8	1/2	1/4	5/8	1 29/32	§	5 3/4	5 3/8
	1†	3/4-16	7/8-14		1 1/8	1 1/2	1/2	7/8	1/2	1	2 9/32	§	6 1/8	5 3/4
2	5/8	7/16-20	1/2-20		3/4	1 1/8	3/8	1/2	1/4	5/8	1 29/32	§	5 3/4	5 3/8
	1	3/4-16	7/8-14		1 1/8	1 1/2	1/2	7/8	1/2	1	2 9/32	§	6 1/8	5 3/4
2 1/2	5/8	7/16-20	1/2-20		3/4	1 1/8	3/8	1/2	1/4	5/8	1 29/32	2 3/8	5 7/8	5 1/2
	1	3/4-16	7/8-14		1 1/8	1 1/2	1/2	7/8	1/2	1	2 9/32	2 5/8	6 1/4	5 7/8
3 1/4	1	3/4-16	7/8-14		1 1/8	1 1/2	1/2	7/8	1/4	3/4	2 7/16	2 5/8	7 1/2	6 7/8
	1 3/8	1-14	1 1/4-12		1 5/8	2	5/8	1 1/8	3/8	1	2 11/16	3 7/32	7 3/4	7 1/8
4	1	3/4-16	7/8-14		1 1/8	1 1/2	1/2	7/8	1/4	3/4	2 7/16	2 5/8	7 1/2	6 7/8
	1 3/8	1-14	1 1/4-12		1 5/8	2	5/8	1 1/8	3/8	1	2 11/16	3 7/32	7 3/4	7 1/8
5	1	3/4-16	7/8-14		1 1/8	1 1/2	1/2	7/8	1/4	3/4	2 7/16	2 5/8	7 3/4	7 1/8
	1 3/8	1-14	1 1/4-12		1 5/8	2	5/8	1 1/8	3/8	1	2 11/16	3 7/32	8	7 3/8
6	1 3/8	1-14	1 1/4-12		1 5/8	2	5/8	1 1/8	1/4	7/8	2 13/16	3 7/32	8 7/8	8 1/8
	1 3/4	1 1/4-12	1 1/2-12		2	2 3/8	3/4	1 1/2	3/8	1 1/8	3 1/16	3 7/8	9 1/8	8 3/8

- † HEAD END PORTS SHALLOW TAPPED
- CUSHION NOT AVAILABLE ON HEAD END
- § THESE CYLINDERS HAVE FULL PLATE RETAINERS. USE "E" DIMENSION INSTEAD OF "RM" - SEE PAGE 82
- ‡ B DIMENSION TOLERANCE -.001/ -.003
- * MAXIMUM WIDTH OF MATING PART
- EYE DESIGNED TO FIT YATES STD CLEVIS BRACKET.



INTERMEDIATE FIXED TRUNNION MOUNT

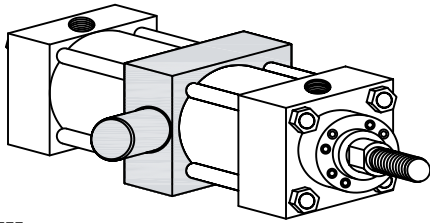

“T”
YATES STYLE T
NFPA-MT4

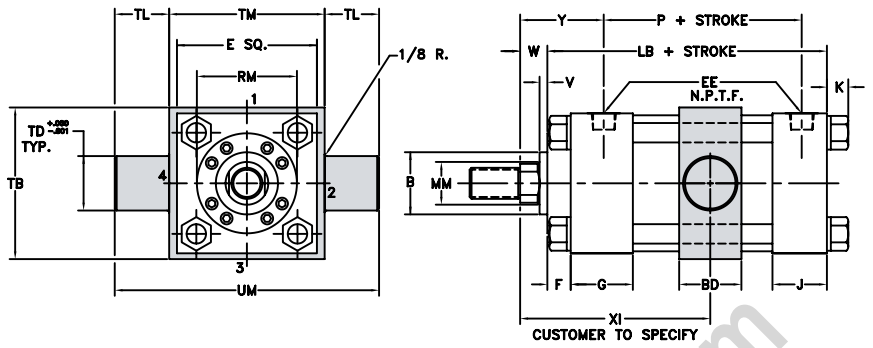

HEAD TRUNNION MOUNT

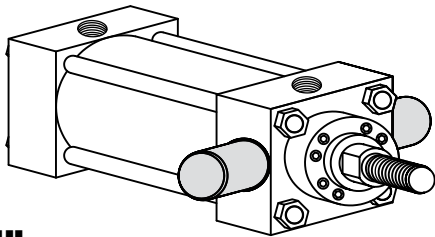

“U”
YATES STYLE U
NFPA-MT1

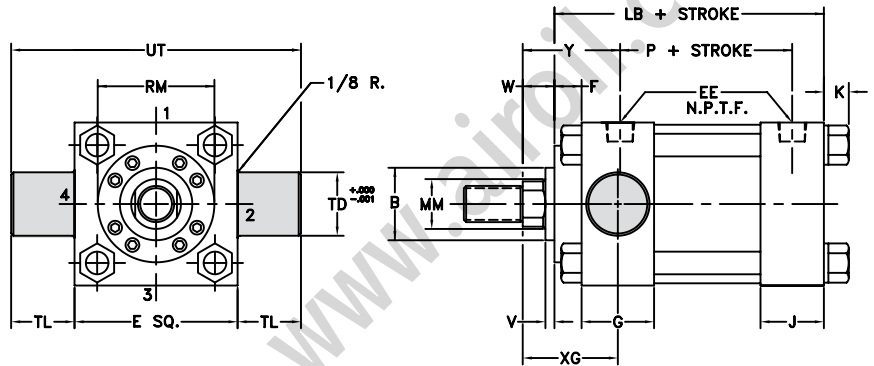

CAP TRUNNION MOUNT

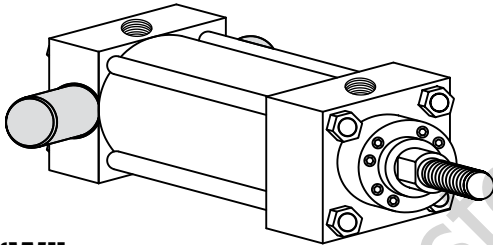

“W”
YATES STYLE W
NFPA-MT2

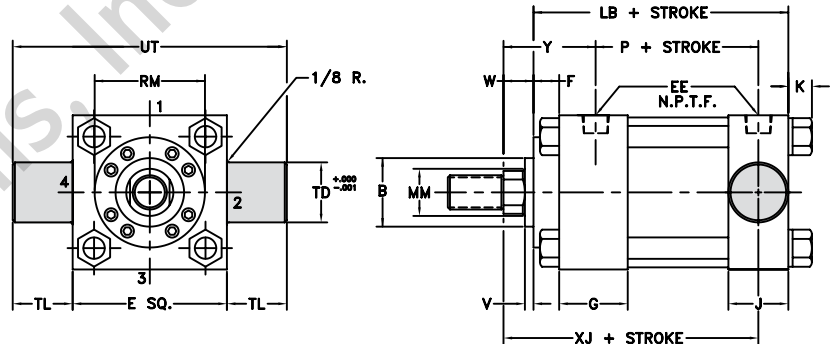

STANDARD ROD ENDS

#2 STD MALE NFPA-SM

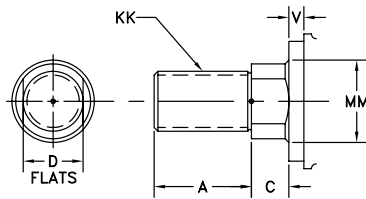

#4 STD FEMALE NFPA-SF

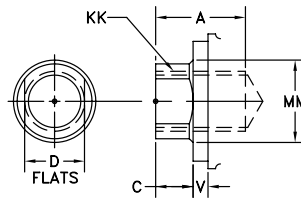

#1 MALE NFPA-1M

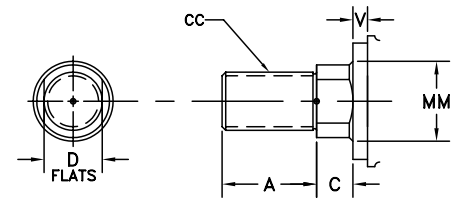

BORE	E	EE	F	G	J	K	TD	TL	UT	TB	BD	TM	UM	XI	ADD STROKE	
															LB	P
1 1/2	2	3/8	3/8	1 1/2	1	1/4	1	1	4	2 1/2	1 1/4	2 1/2	4 1/2	SPECIFY	4	2 1/4
2	2 1/2	3/8	3/8	1 1/2	1	5/16	1	1	4 1/2	3	1 1/2	3	5		4	2 1/4
2 1/2	3	3/8	3/8	1 1/2	1	5/16	1	1	5	3 1/2	1 1/2	3 1/2	5 1/2		4 1/8	2 3/8
3 1/4	3 3/4	1/2	5/8	1 3/4	1 1/4	3/8	1	1	5 3/4	4 1/4	2	4 1/2	6 1/2		4 7/8	2 5/8
4	4 1/2	1/2	5/8	1 3/4	1 1/4	3/8	1	1	6 1/2	5	2	5 1/4	7 1/4		4 7/8	2 5/8
5	5 1/2	1/2	5/8	1 3/4	1 1/4	7/16	1	1	7 1/2	6	2	6 1/4	8 1/4		5 1/8	2 7/8
6	6 1/2	3/4	3/4	2	1 1/2	7/16	1 3/8	1 3/8	9 1/4	7	2 1/2	7 5/8	10 3/8		5 3/4	3 1/8
8	8 1/2	3/4	3/4	2	1 1/2	9/16	1 3/8	1 3/8	11 1/4	9 1/2	2 1/2	9 3/4	12 1/2		5 7/8	3 1/4

BORE	ROD DIA.	THREAD		ROD EXTENSIONS AND PILOT DIMENSIONS										ADD STROKE
	MM	KK	CC	A	B ±	C	D	V	W	Y	RM	XG	XJ	
1 1/2	5/8	7/16-20	1/2-20	3/4	1 1/8	3/8	1/2	1/4	5/8	1 29/32	§	1 3/4	4 1/8	
	1†Ω	3/4-16	7/8-14	1 1/8	1 1/2	1/2	7/8	1/2	1	2 9/32	§	*	4 1/2	
2	5/8	7/16-20	1/2-20	3/4	1 1/8	3/8	1/2	1/4	5/8	1 29/32	§	1 3/4	4 1/8	
	1	3/4-16	7/8-14	1 1/8	1 1/2	1/2	7/8	1/2	1	2 9/32	§	2 1/8	4 1/2	
2 1/2	5/8	7/16-20	1/2-20	3/4	1 1/8	3/8	1/2	1/4	5/8	1 29/32	2 3/8	1 3/4	4 1/4	
	1	3/4-16	7/8-14	1 1/8	1 1/2	1/2	7/8	1/2	1	2 9/32	2 5/8	2 1/8	4 5/8	
3 1/4	1	3/4-16	7/8-14	1 1/8	1 1/2	1/2	7/8	1/4	3/4	2 7/16	2 5/8	2 1/4	5	
	1 3/8	1-14	1 1/4-12	1 5/8	2	5/8	1 1/8	3/8	1	2 11/16	3 7/32	2 1/2	5 1/4	
4	1	3/4-16	7/8-14	1 1/8	1 1/2	1/2	7/8	1/4	3/4	2 7/16	2 5/8	2 1/4	5	
	1 3/8	1-14	1 1/4-12	1 5/8	2	5/8	1 1/8	3/8	1	2 11/16	3 7/32	2 1/2	5 1/4	
5	1	3/4-16	7/8-14	1 1/8	1 1/2	1/2	7/8	1/4	3/4	2 7/16	2 5/8	2 1/4	5 1/4	
	1 3/8	1-14	1 1/4-12	1 5/8	2	5/8	1 1/8	3/8	1	2 11/16	3 7/32	2 1/2	5 1/2	
6	1 3/8	1-14	1 1/4-12	1 5/8	2	5/8	1 1/8	1/4	7/8	2 13/16	3 7/32	2 5/8	5 7/8	
	1 3/4	1 1/4-12	1 1/2-12	2	2 3/8	3/4	1 1/2	3/8	1 1/8	3 1/16	3 7/8	2 7/8	6 1/8	
8	1 3/8	1-14	1 1/4-12	1 5/8	2	5/8	1 1/8	1/4	7/8	2 13/16	3 7/32	2 5/8	6	
	1 3/4	1 1/4-12	1 1/2-12	2	2 3/8	3/4	1 1/2	3/8	1 1/8	3 1/16	3 7/8	2 7/8	6 1/4	

† HEAD END PORTS SHALLOW TAPPED
 Ω CUSHION NOT AVAILABLE ON HEAD END
 § THESE CYLINDERS HAVE FULL PLATE RETAINERS. USE "E" DIMENSION INSTEAD OF "RM" - SEE PAGE 82
 ‡ B DIMENSION TOLERANCE -.001/-.003
 * THIS MOUNT NOT AVAILABLE 1 1/2" BORE WITH 1" ROD



HEAD RECTANGULAR FLANGE MOUNT

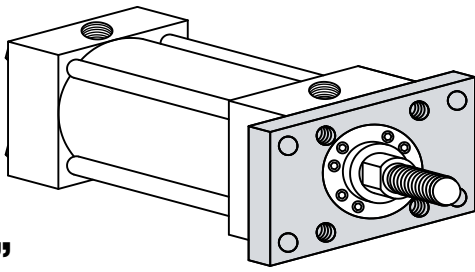

“F”

YATES STYLE **F**
NFPA-MF1

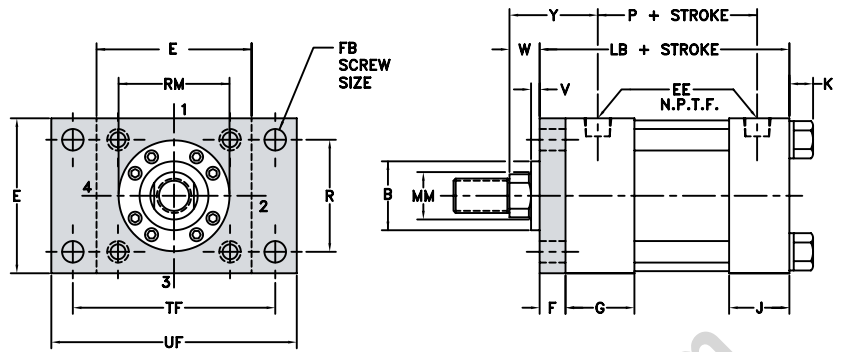

HEAD SQUARE FLANGE MOUNT

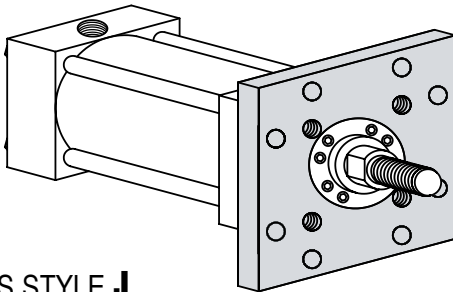

“J”

YATES STYLE **J**
NFPA-MF5

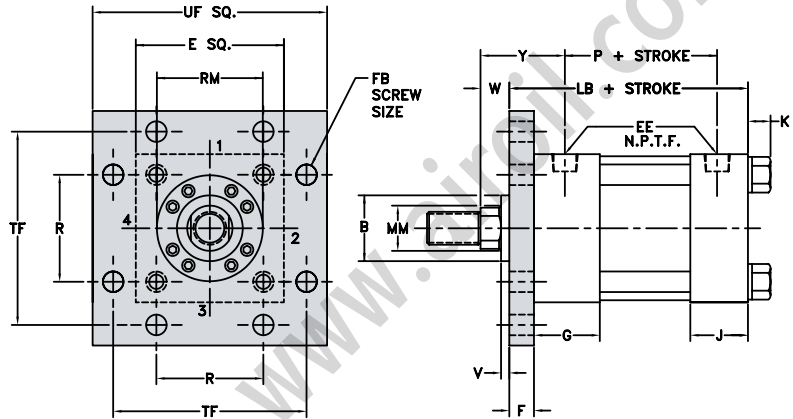

CAP RECTANGULAR FLANGE MOUNT

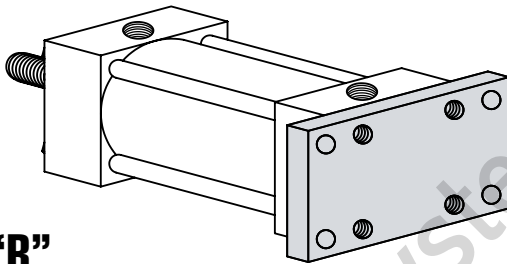

“R”

YATES STYLE **R**
NFPA-MF2

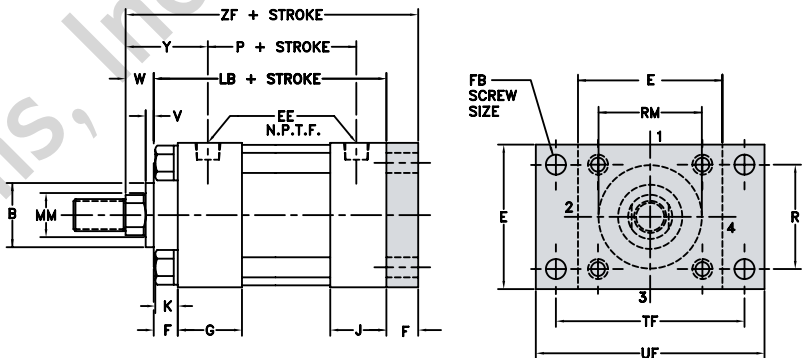

CAP SQUARE FLANGE MOUNT

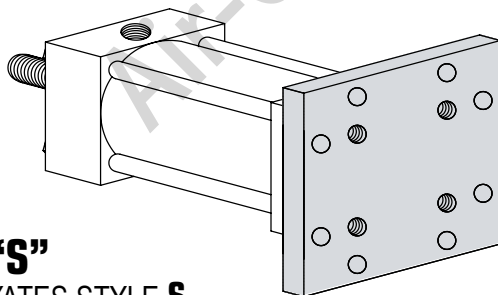

“S”

YATES STYLE **S**
NFPA-MF6

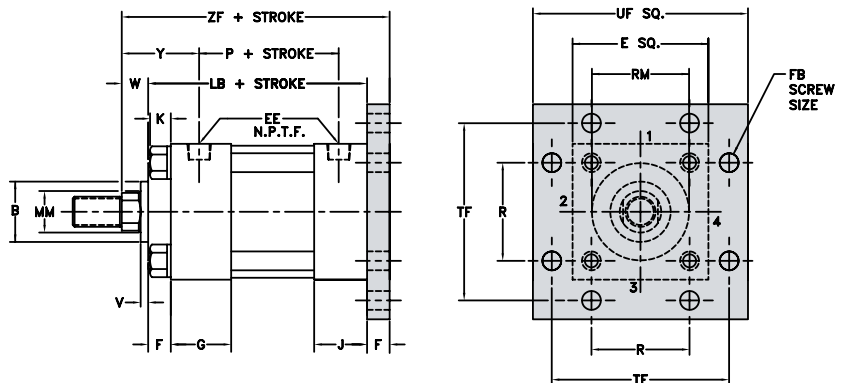

STANDARD ROD ENDS

#2 STD MALE NFPA-SM

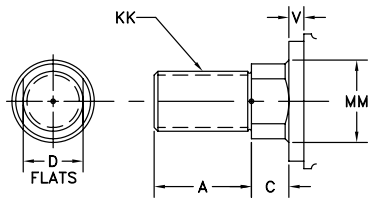

#4 STD FEMALE NFPA-SF

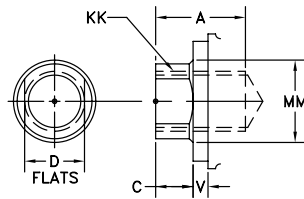

#1 MALE NFPA-IM

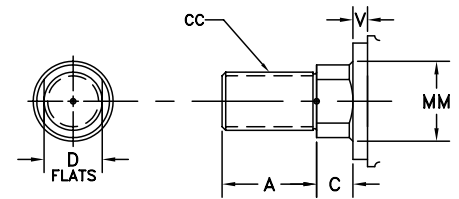

BORE	E	EE	F	G	J	K	FB	R	TF	UF	ADD STROKE	
											LB	P
1 1/2	2	3/8	3/8	1 1/2	1	1/4	1/4	1.43	2 3/4	3 3/8	4	2 1/4
2	2 1/2	3/8	3/8	1 1/2	1	5/16	5/16	1.84	3 3/8	4 1/8	4	2 1/4
2 1/2	3	3/8	3/8	1 1/2	1	5/16	5/16	2.19	3 7/8	4 5/8	4 1/8	2 3/8
3 1/4	3 3/4	1/2	5/8	1 3/4	1 1/4	3/8	3/8	2.76	4 11/16	5 1/2	4 7/8	2 5/8
4	4 1/2	1/2	5/8	1 3/4	1 1/4	3/8	3/8	3.32	5 7/16	6 1/4	4 7/8	2 5/8
5	5 1/2	1/2	5/8	1 3/4	1 1/4	7/16	1/2	4.10	6 5/8	7 5/8	5 1/8	2 7/8
6	6 1/2	3/4	3/4	2	1 1/2	7/16	1/2	4.88	7 5/8	8 5/8	5 3/4	3 1/8

BORE	ROD DIA.		THREAD		ROD EXTENSIONS AND PILOT DIMENSIONS								ADD STROKE	
	MM	KK	CC	A	B ±	C	D	V	Y	W	RM	ZF		
1 1/2	5/8	7/16-20	1/2-20	3/4	1 1/8	3/8	1/2	1/4	1 29/32	5/8	§	5		
	1 †Ω	3/4-16	7/8-14	1 1/8	1 1/2	1/2	7/8	1/2	2 9/32	1	§	5 3/8		
2	5/8	7/16-20	1/2-20	3/4	1 1/8	3/8	1/2	1/4	1 29/32	5/8	§	5		
	1	3/4-16	7/8-14	1 1/8	1 1/2	1/2	7/8	1/2	2 9/32	1	§	5 3/8		
2 1/2	5/8	7/16-20	1/2-20	3/4	1 1/8	3/8	1/2	1/4	1 29/32	5/8	2 3/8	5 1/8		
	1	3/4-16	7/8-14	1 1/8	1 1/2	1/2	7/8	1/2	2 9/32	1	2 5/8	5 1/2		
3 1/4	1	3/4-16	7/8-14	1 1/8	1 1/2	1/2	7/8	1/4	2 7/16	3/4	2 5/8	6 1/4		
	1 3/8	1-14	1 1/4-12	1 5/8	2	5/8	1 1/8	3/8	2 11/16	1	3 7/32	6 1/2		
4	1	3/4-16	7/8-14	1 1/8	1 1/2	1/2	7/8	1/4	2 7/16	3/4	2 5/8	6 1/4		
	1 3/8	1-14	1 1/4-12	1 5/8	2	5/8	1 1/8	3/8	2 11/16	1	3 7/32	6 1/2		
5	1	3/4-16	7/8-14	1 1/8	1 1/2	1/2	7/8	1/4	2 7/16	3/4	2 5/8	6 1/2		
	1 3/8	1-14	1 1/4-12	1 5/8	2	5/8	1 1/8	3/8	2 11/16	1	3 7/32	6 3/4		
6	1 3/8	1-14	1 1/4-12	1 5/8	2	5/8	1 1/8	1/4	2 13/16	7/8	3 7/32	7 3/8		
	1 3/4	1 1/4-12	1 1/2-12	2	2 3/8	3/4	1 1/2	3/8	3 1/16	1 1/8	3 7/8	7 5/8		

† HEAD END PORTS SHALLOW TAPPED
 Ω CUSHION NOT AVAILABLE ON HEAD END
 § THESE CYLINDERS HAVE FULL PLATE RETAINERS. USE "E" DIMENSION INSTEAD OF "RM" - SEE PAGE 82
 ± B DIMENSION TOLERANCE -.001/-.003



HEAD SQUARE INTEGRAL FLANGE MOUNT

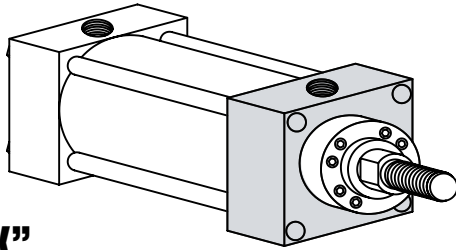

“X”
YATES STYLE X
NFPA-ME3

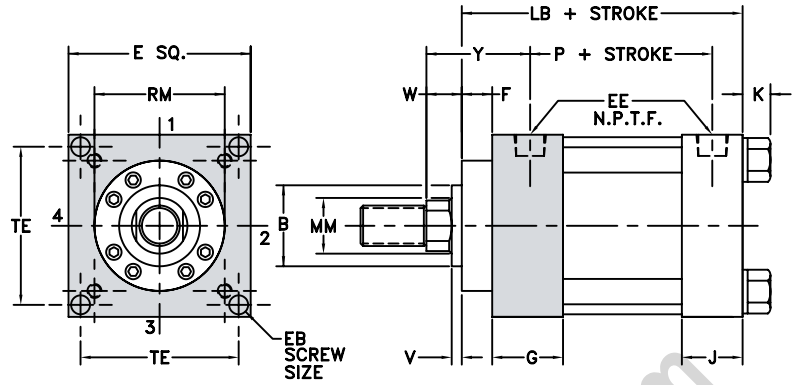

CAP SQUARE INTEGRAL FLANGE MOUNT

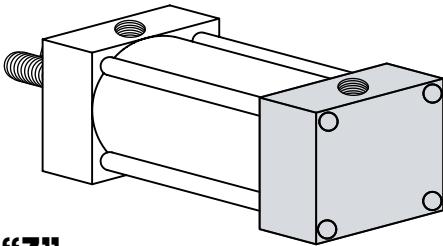

“Z”
YATES STYLE Z
NFPA-ME4

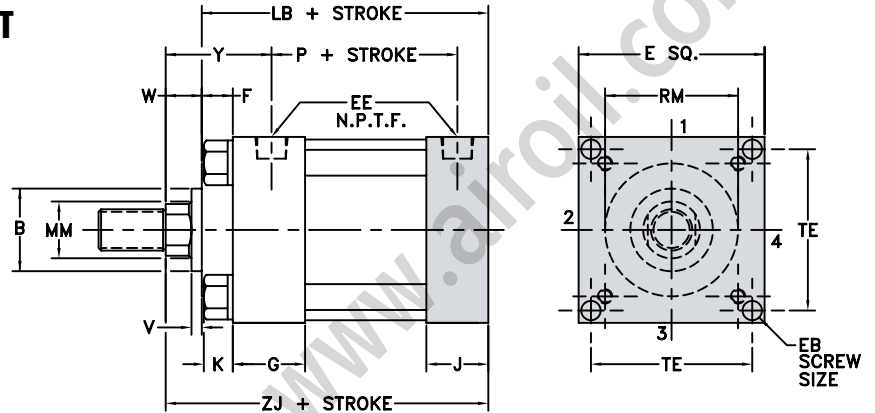

STANDARD ROD ENDS

#2 STD MALE
NFPA-SM

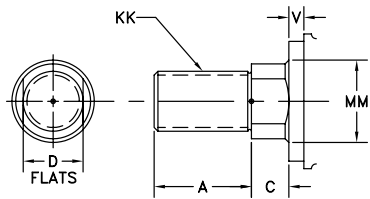

#4 STD FEMALE
NFPA-SF

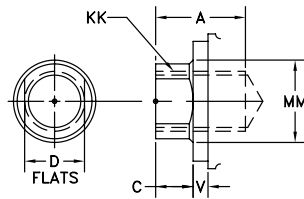

#1 MALE
NFPA-IM

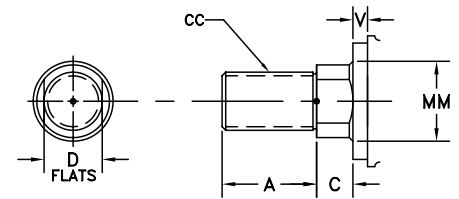

BORE	E	EE	F	G	J	K	EB	TE	ADD STROKE	
									LB	P
8	8 1/2	3/4	3/4	2	1 1/2	9/16	5/8	7.57	5 7/8	3 1/4

BORE	ROD DIA.	THREAD		ROD EXTENSIONS AND PILOT DIMENSIONS								ADD STROKE
	MM	KK	CC	A	B ‡	C	D	V	W	Y	RM	ZJ
8	1 3/8	1-14	1 1/4-12	1 5/8	2	5/8	1 1/8	1/4	7/8	2 13/16	3 7/32	6 3/4
	1 3/4	1 1/4-12	1 1/2-12	2	2 3/8	3/4	1 1/2	3/8	1 1/8	3 1/16	3 7/8	7

‡ B DIMENSION TOLERANCE -.001/-.003

Air-Oil Systems, Inc. www.airoil.com



NO TIE RODS EXTENDED MOUNT

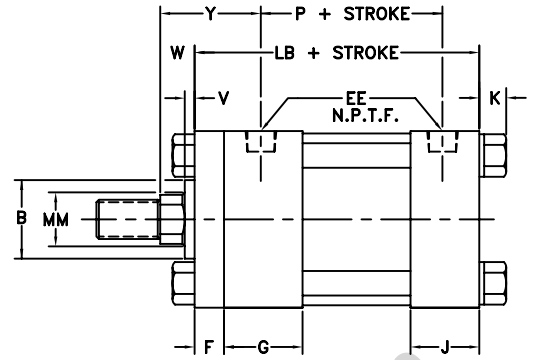
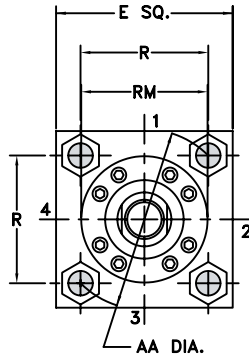
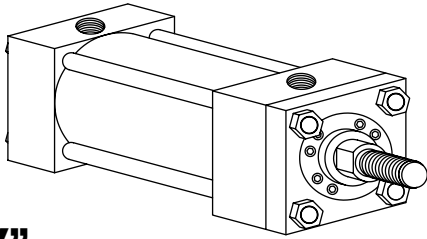

“K”

YATES STYLE **K**
NFPA-MX0

BOTH ENDS TIE RODS EXTENDED MOUNT

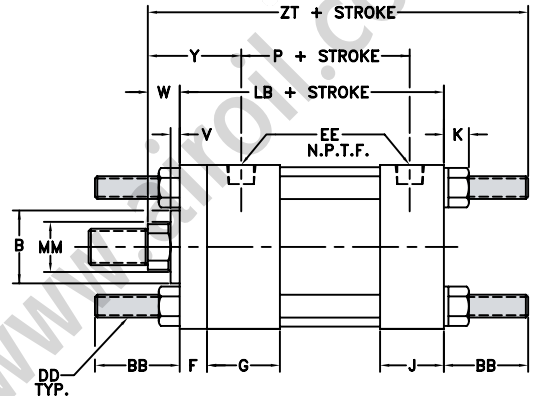
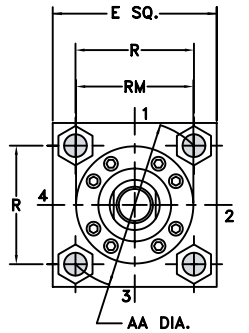
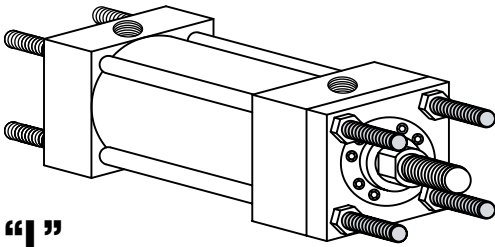

“L”

YATES STYLE **L**
NFPA-MX1

HEAD TIE RODS EXTENDED MOUNT

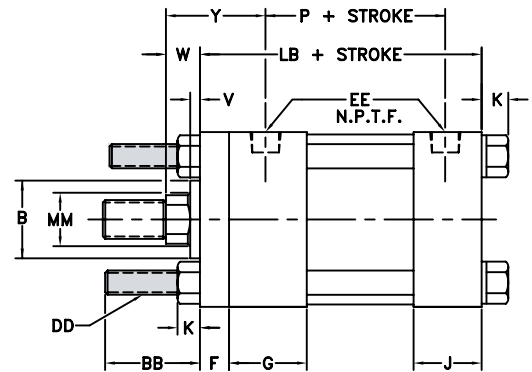
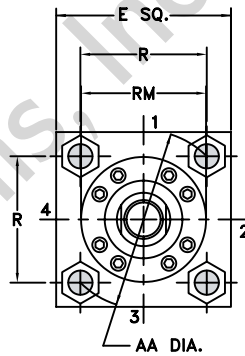
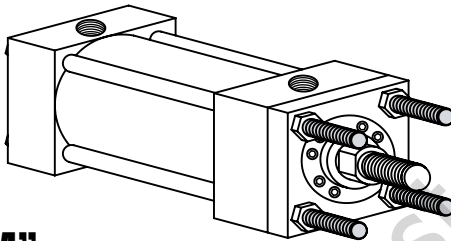

“M”

YATES STYLE **M**
NFPA-MX3

CAP TIE RODS EXTENDED MOUNT

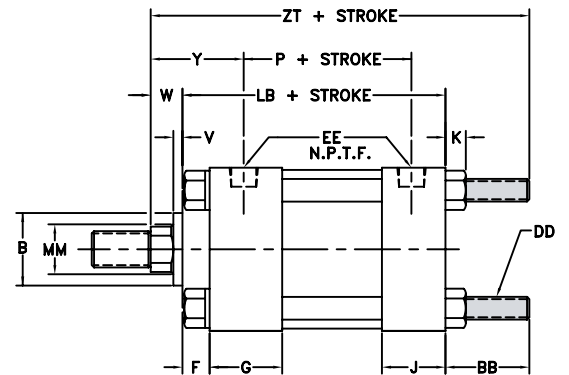
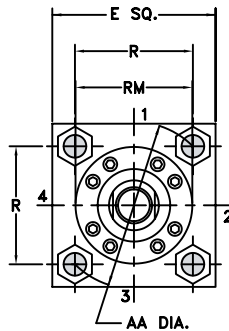
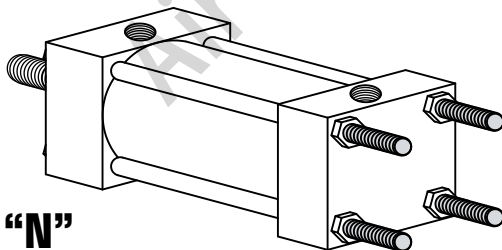

“N”

YATES STYLE **N**
NFPA-MX2

STANDARD ROD ENDS

#2 STD MALE NFPA-SM

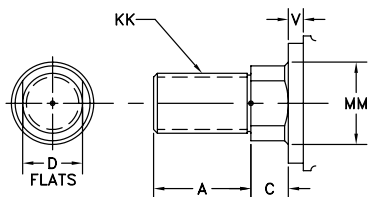

#4 STD FEMALE NFPA-SF

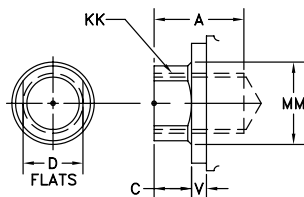

#1 MALE NFPA-IM

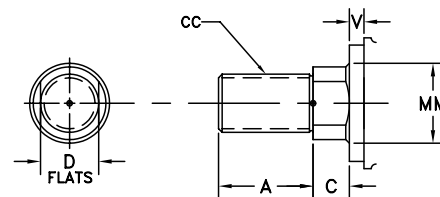

BORE	E	EE	F	G	J	K	AA	BB	DD	R	ADD STROKE	
											LB	P
1 1/2	2	3/8	3/8	1 1/2	1	1/4	2.02	1	1/4-28	1.43	4	2 3/16
2	2 1/2	3/8	3/8	1 1/2	1	5/16	2.60	1 1/8	5/16-24	1.84	4	2 3/16
2 1/2	3	3/8	3/8	1 1/2	1	5/16	3.10	1 1/8	5/16-24	2.19	4 1/8	2 5/16
3 1/4	3 3/4	1/2	5/8	1 3/4	1 1/4	3/8	3.90	1 3/8	3/8-24	2.76	4 7/8	2 5/8
4	4 1/2	1/2	5/8	1 3/4	1 1/4	3/8	4.70	1 3/8	3/8-24	3.32	4 7/8	2 5/8
5	5 1/2	1/2	5/8	1 3/4	1 1/4	7/16	5.80	1 13/16	1/2-20	4.10	5 1/8	2 7/8
6	6 1/2	3/4	3/4	2	1 1/2	7/16	6.90	1 13/16	1/2-20	4.88	5 3/4	3 1/8
8	8 1/2	3/4	3/4	2	1 1/2	9/16	9.11	2 5/16	5/8-18	6.44	5 7/8	3 1/4

BORE	ROD DIA. MM	THREAD		ROD EXTENSIONS AND PILOT DIMENSION								ADD STROKE ZT*
		KK	CC	A	B ±	C	D	V	W	Y	RM	
1 1/2	5/8	7/16-20	1/2-20	3/4	1 1/8	3/8	1/2	1/4	5/8	1 29/32	§	5 5/8
	1 †	3/4-16	7/8-14	1 1/8	1 1/2	1/2	7/8	1/2	1	2 9/32	§	6
2	5/8	7/16-20	1/2-20	3/4	1 1/8	3/8	1/2	1/4	5/8	1 29/32	§	5 3/4
	1	3/4-16	7/8-14	1 1/8	1 1/2	1/2	7/8	1/2	1	2 9/32	§	6 1/8
2 1/2	5/8	7/16-20	1/2-20	3/4	1 1/8	3/8	1/2	1/4	5/8	1 29/32	2 3/8	5 7/8
	1	3/4-16	7/8-14	1 1/8	1 1/2	1/2	7/8	1/2	1	2 9/32	2 5/8	6 1/4
3 1/4	1	3/4-16	7/8-14	1 1/8	1 1/2	1/2	7/8	1/4	3/4	2 7/16	2 5/8	7
	1 3/8	1-14	1 1/4-12	1 5/8	2	5/8	1 1/8	3/8	1	2 11/16	3 7/32	7 1/4
4	1	3/4-16	7/8-14	1 1/8	1 1/2	1/2	7/8	1/4	3/4	2 7/16	2 5/8	7
	1 3/8	1-14	1 1/4-12	1 5/8	2	5/8	1 1/8	3/8	1	2 11/16	3 7/32	7 1/4
5	1	3/4-16	7/8-14	1 1/8	1 1/2	1/2	7/8	1/4	3/4	2 7/16	2 5/8	7 11/16
	1 3/8	1-14	1 1/4-12	1 5/8	2	5/8	1 1/8	3/8	1	2 11/16	3 7/32	7 15/16
6	1 3/8	1-14	1 1/4-12	1 5/8	2	5/8	1 1/8	1/4	7/8	2 13/16	3 7/32	8 7/16
	1 3/4	1 1/4-12	1 1/2-12	2	2 3/8	3/4	1 1/2	3/8	1 1/8	3 1/16	3 7/8	8 11/16
8	1 3/8	1-14	1 1/4-12	1 5/8	2	5/8	1 1/8	1/4	7/8	2 13/16	3 7/32	9 1/16
	1 3/4	1 1/4-12	1 1/2-12	2	2 3/8	3/4	1 1/2	3/8	1 1/8	3 1/16	3 7/32	9 5/16

† HEAD END PORTS SHALLOW TAPPED

• CUSHION NOT AVAILABLE ON HEAD END

§ THESE CYLINDERS HAVE FULL PLATE RETAINERS. USE "E" DIMENSION INSTEAD OF "RM" - SEE PAGE 82

‡ B DIMENSION TOLERANCE -.001/ -.003

* ZT CHANGES ON DOUBLE ROD CYLINDERS SEE PAGE 100 FOR DETAILS

NOTE: 1 1/2 AND 2" BORE CYLINDERS ON "K" AND "N" MOUNTS AND 1 1/2" THRU 6" BORE CYLINDERS ON "L" AND "M" MOUNTS HAVE FULL PLATE RETAINERS. USE "E" SQ DIMENSION INSTEAD OF "RM"



DOUBLE ROD END STYLES

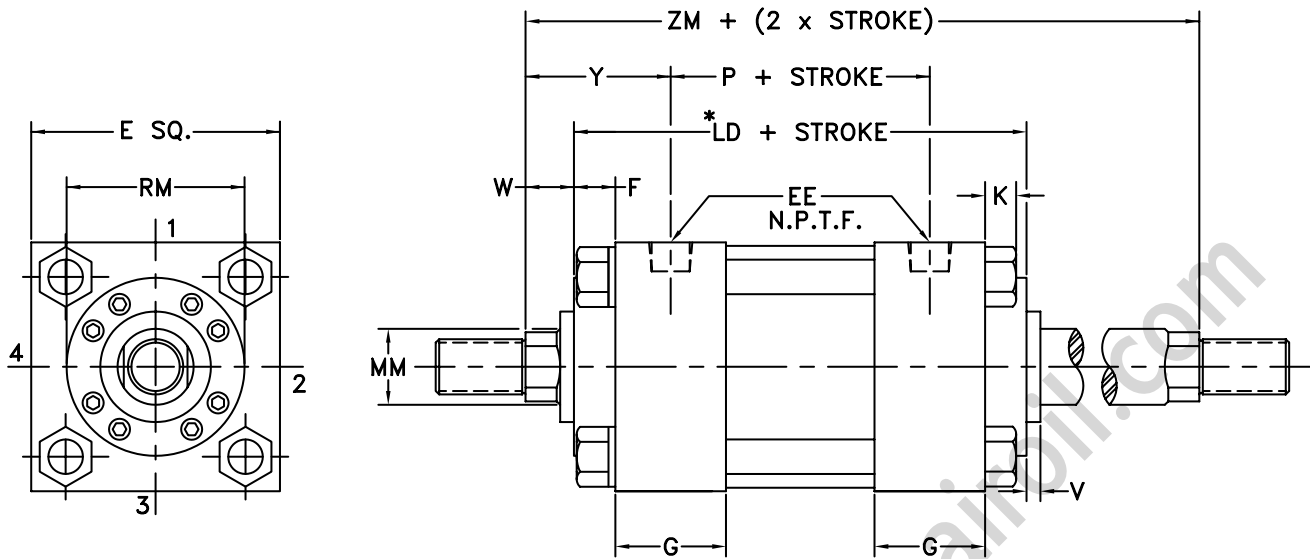

AVAILABLE IN MOUNTING STYLES A, B, E, F, J, K, L, M, T, U, X AND Y

"U" mount not available 1 1/2" bore with 1" rod

"B" mount not available with standard dimensions 1 1/2" bore with 1" rod

* "LD" replaces "LB" dimensions on all styles with double rod ends.

FOR ORDERING DOUBLE ROD END CYLINDERS ADD "D" AFTER MOUNTING STYLE

(Example: Style "A" side lugs' mount with double rod end is style "A2-AD")

If the two rod ends are different, state which rod end is to go at which end of the cylinder.

If only one end of the cylinder is to be cushioned, specify clearly which end.

BORE	ROD DIA.	ADD STROKE							ADD 2X STROKE
	MM	LD*	SA _D	SE _D	SS _D	XE _D	ZE _D	ZT _D	ZM
1 1/2	5/8	4 7/8	6 7/8	6 3/8	3 3/8	6 1/4	6 1/2	6 1/2	6 1/8
	1	4 7/8	6 7/8	6 3/8	3 3/8	6 5/8	6 7/8	6 7/8	6 7/8
2	5/8	4 7/8	6 7/8	6 3/4	3 3/8	6 7/16	6 3/4	6 5/8	6 1/8
	1	4 7/8	6 7/8	6 3/4	3 3/8	6 13/16	7 1/8	7	6 7/8
2 1/2	5/8	5	7	7 1/8	3 1/2	6 11/16	7	6 3/4	6 1/4
	1	5	7	7 1/8	3 1/2	7 1/16	7 3/8	7 1/8	7
3 1/4	1	6	8 1/2	7 3/4	3 3/4	7 5/8	8	8 1/8	7 1/2
	1 3/8	6	8 1/2	7 3/4	3 3/4	7 7/8	8 1/4	8 3/8	8
4	1	6	8 1/2	8	3 3/4	7 3/4	8 1/8	8 1/8	7 1/2
	1 3/8	6	8 1/2	8	3 3/4	8	8 3/8	8 3/8	8
5	1	6 1/4	9	8 3/8	3 5/8	8 1/16	8 9/16	8 13/16	7 3/4
	1 3/8	6 1/4	9	8 3/8	3 5/8	8 5/16	8 13/16	9 1/16	8 1/4
6	1 3/8	7	9 3/4	9	4 1/8	8 7/8	9 3/8	9 11/16	8 3/4
	1 3/4	7	9 3/4	9	4 1/8	9 1/8	9 5/8	9 15/16	9 1/4
8	1 3/8	7 1/8	9 1/4	7 7/8	4 1/4	8 3/8	9	9 9/16	8 7/8
	1 3/4	7 1/8	9 1/4	7 7/8	4 1/4	8 5/8	9 1/4	9 13/16	9 3/8

STANDARD ROD END STYLES

ROD END STYLE #	DIMENSIONS	ROD END STYLE #	DIMENSIONS																																									
#2** STANDARD MALE (NFPA-SM)		#4 STANDARD FEMALE (NFPA-SF)																																										
#1 STANDARD MALE (NFPA-IM)		<table border="1"> <thead> <tr> <th colspan="6">ADDITIONAL DIMENSIONS</th> </tr> <tr> <th rowspan="2">ROD MM</th> <th colspan="3">STYLE 9</th> <th colspan="2">STYLE 8</th> </tr> <tr> <th>AC +/-0.030</th> <th>AD +/-0.010</th> <th>AE+0.000/-0.010</th> <th>AF +/-0.010</th> <th>FT</th> </tr> </thead> <tbody> <tr> <td>5/8</td> <td>1 1/8</td> <td>5/8</td> <td>1/4</td> <td>3/8</td> <td>5/8-18</td> </tr> <tr> <td>1</td> <td>1 1/2</td> <td>15/16</td> <td>3/8</td> <td>11/16</td> <td>1-14</td> </tr> <tr> <td>1 3/8</td> <td>1 3/4</td> <td>1 1/16</td> <td>3/8</td> <td>7/8</td> <td>1 3/8-12</td> </tr> <tr> <td>1 3/4</td> <td>2</td> <td>1 5/16</td> <td>1/2</td> <td>1 1/8</td> <td>1 3/4-12</td> </tr> </tbody> </table>		ADDITIONAL DIMENSIONS						ROD MM	STYLE 9			STYLE 8		AC +/-0.030	AD +/-0.010	AE+0.000/-0.010	AF +/-0.010	FT	5/8	1 1/8	5/8	1/4	3/8	5/8-18	1	1 1/2	15/16	3/8	11/16	1-14	1 3/8	1 3/4	1 1/16	3/8	7/8	1 3/8-12	1 3/4	2	1 5/16	1/2	1 1/8	1 3/4-12
ADDITIONAL DIMENSIONS																																												
ROD MM	STYLE 9			STYLE 8																																								
	AC +/-0.030	AD +/-0.010	AE+0.000/-0.010	AF +/-0.010	FT																																							
5/8	1 1/8	5/8	1/4	3/8	5/8-18																																							
1	1 1/2	15/16	3/8	11/16	1-14																																							
1 3/8	1 3/4	1 1/16	3/8	7/8	1 3/8-12																																							
1 3/4	2	1 5/16	1/2	1 1/8	1 3/4-12																																							

ROD END STYLE #	DIMENSIONS	ROD END STYLE #	DIMENSIONS
#5		#3 (NFPA-LF)	
#6		#7 (NFPA-PL)	
#9		#8 (NFPA-FM)	

**** MALE ROD END STYLE #2 WILL BE FURNISHED UNLESS OTHERWISE SPECIFIED**

(4) SPANNER HOLES USED INSTEAD OF FLATS ON 4" DIA. AND LARGER.

NOTE: CONSULT FACTORY FOR ROD END CONFIGURATIONS OTHER THAN THOSE SHOWN.

NOTE: ALL YATES MOUNTING ACCESSORIES ARE DESIGNED TO FIT #2 ROD END STYLES



FEMALE CLEVIS

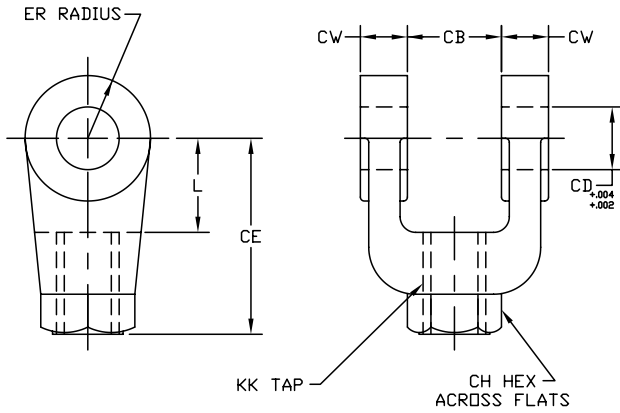

PART NO.	CB	CD	CE	CH	CW	ER	KK	L
10-YFC-134-05-A	3/4	1/2	1 1/2	1	1/2	1/2	7/16-20	3/4
10-YFC-134-08-A	1 1/4	3/4	2 3/8	1 1/4	5/8	3/4	3/4-16	1 1/4
10-YFC-134-08-M	1 1/4	3/4	2 1/8	1 3/8	5/8	3/4	3/4-16	1
10-YFC-134-11-A	1 1/2	1	3 1/8	1 1/2	3/4	1	1-14	1 1/2
10-YFC-134-11-M	1 1/2	1	2 15/16	1 1/2	3/4	1	1-14	1 5/16
10-YFC-134-14-A	2	1 3/8	4 1/8	2	1	1 3/8	1 1/4-12	2 1/8
10-YFC-134-14-M	2	1 3/8	3 3/4	2	1	1 3/8	1 1/4-12	1 3/4
10-YFC-134-16-A	2 1/2	1 3/4	4 1/2	2 3/8	1 1/4	1 3/4	1 1/2-12	2 1/4

ROD COUPLERS

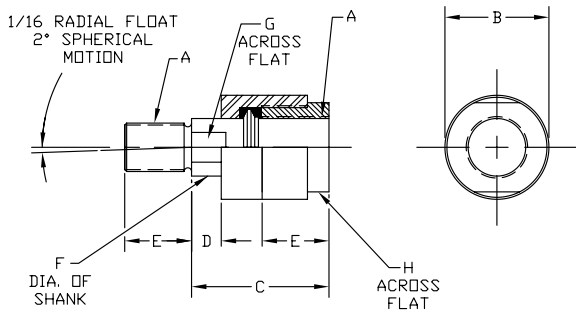

PART NUMBER	ROD DIA.	A	B	C	D	E	F	G	H	MAX PULL
11-YAC-2-05	5/8	7/16-20	1 1/4	2	1/2	3/4	5/8	1/2	1	10,000
11-YAC-2-06	5/8	1/2-20	1 1/4	2	1/2	3/4	5/8	1/2	1	14,000
11-YAC-2-07	5/8	5/8-18	1 1/4	2	1/2	3/4	5/8	1/2	1	19,000
11-YAC-2-08	1	3/4-16	1 3/4	2 5/16	1/2	1 1/8	31/32	13/16	1 1/2	34,000
11-YAC-2-09	1	7/8-14	1 3/4	2 5/16	1/2	1 1/8	31/32	13/16	1 1/2	39,000
11-YAC-2-11	1 3/8	1-14	2 1/2	2 15/16	1/2	1 5/8	1 3/8	1 5/32	2 1/4	64,000
11-YAC-2-14	1 3/8	1 1/4-12	2 1/2	2 15/16	1/2	1 5/8	1 3/8	1 5/32	2 1/4	78,000
11-YAC-2-15	1 3/8	1 3/8-12	2 1/2	2 15/16	1/2	1 5/8	1 3/8	1 5/32	2 1/4	78,000
11-YAC-2-16	2	1 1/2-12	3 1/4	4 3/8	13/16	2 1/4	1 3/4	1 1/2	3	134,000

CLEVIS BRACKET

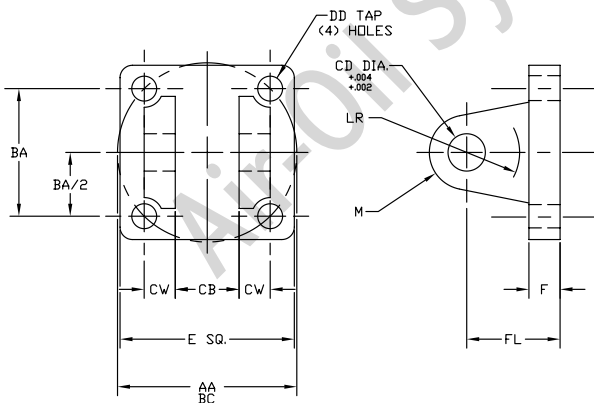

PART NUMBER	AA	BA	CB	CD	CW	DD	E	F	FL	LR	M
14-YCB-133-03	2.3	1 5/8	25/32	1/2	1/2	5/8-24	2 1/2	3/8	1 1/8	1/2	1/2
14-YCB-133-04	2.9	2 1/16	1 9/32	3/4	5/8	1/2-20	3	5/8	1 7/8	1	3/4
14-YCB-133-05	3.6	2 9/16	1 9/32	3/4	5/8	1/2-20	3 1/2	5/8	1 7/8	1 1/16	3/4
14-YCB-133-06	4.6	3 1/4	1 17/32	1	3/4	5/8-18	4 1/2	3/4	2 1/4	1 1/4	1
14-YCB-133-08	5.4	3 13/16	2 1/32	1 3/8	1	5/8-18	5	7/8	3	1 7/8	1 3/8
14-YCB-133-10	7.0	4 15/16	2 17/32	1 3/4	1 1/4	7/8-14	6 1/2	7/8	3 1/8	2	1 3/4

FEMALE EYE

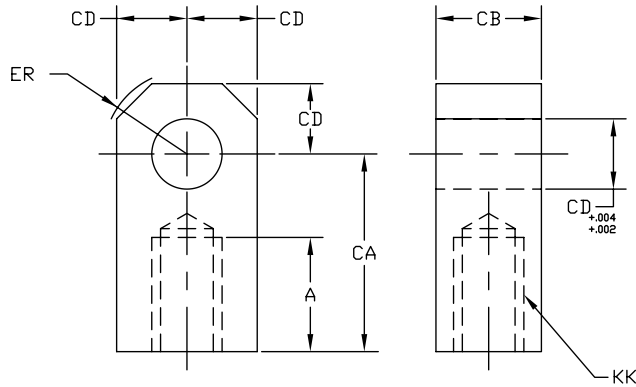

PART NUMBER	A	CA	CB	CD	ER	KK
13-YE-9303	3/4	1/2	3/4	1/2	5/8	7/16-20
13-YE-9304	1 1/8	2 1/16	1 1/4	3/4	7/8	3/4-16
13-YE-9306	1 5/8	2 13/16	1 1/2	1	1 3/16	1-14
13-YE-9306-M	1 1/8	2 3/8	1 1/2	1	1 7/16	7/8-14
13-YE-9308	2	3 7/16	2	1 3/8	1 9/16	1 1/4-12
13-YE-9310	2 1/4	4	2 1/2	1 3/4	2	1 1/2-12

PIVOT PIN

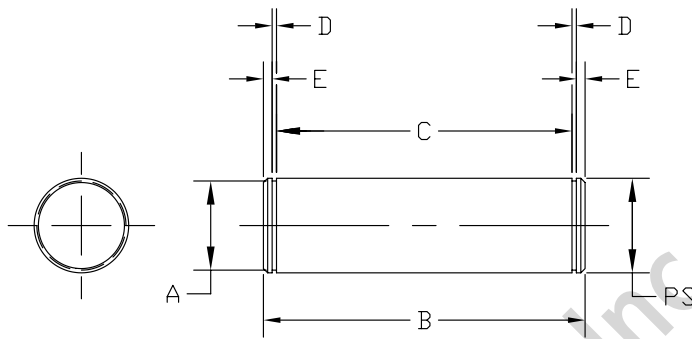

PART NUMBER	PIN SIZE	A	B	C	D	E
12-YP-9003-3-G-A	.500	.470	2.109	1.875	.039	.078
12-YP-9004-3-G-A	.750	.750	2.901	2.625	.046	.092
12-YP-9006-3-G-A	1.000	.943	3.401	3.125	.046	.092
12-YP-9008-3-G-A	1.375	1.295	4.461	4.125	.056	.122
12-YP-9010-3-G-A	1.750	1.655	5.545	5.125	.070	.140

EYE BRACKET

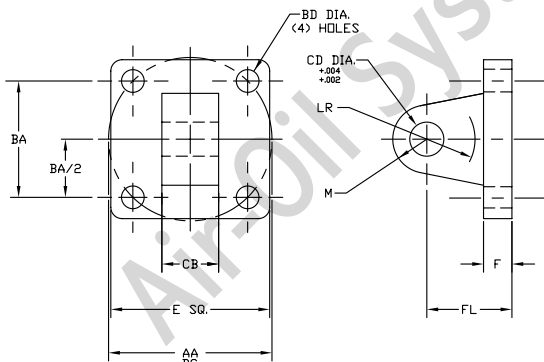

PART NUMBER	AA	BA	BD	CB	CD	E	F	FL	LR	M	M
15-YEB-8903	2.3	1 5/8	13/32	3/4	1/2	2 1/2	3/8	1 1/8	1/2	1/2	11/16
15-YEB-8904	3.6	2 9/16	17/32	1 1/4	3/4	3 1/2	5/8	1 7/8	1	3/4	1 3/16
15-YEB-8906	4.6	3 1/4	21/32	1 1/2	1	4 1/2	3/4	2 1/4	1	1	1 3/8
15-YEB-8908	5.4	3 13/16	21/32	2	1 3/8	5	7/8	3	1 1/8	1 3/8	2
15-YEB-8910	7.0	4 15/16	29/32	2 1/2	1 3/4	6 1/2	7/8	3 1/8	1 3/4	1 3/4	2 1/8

SWIVEL EYE BRACKET

PART NUMBER	AA	BA	BD	CB	CD	E	F	FL	LR	M
15-YSB-219-3-1	2.3	1 5/8	13/32	3/4	1/2	2 1/2	3/8	1 1/8	1/2	11/16
15-YSB-219-3-2	3.6	2 9/16	17/32	1 1/4	3/4	3 1/2	5/8	1 7/8	1	1 3/16
15-YSB-219-3-3	4.6	3 1/4	21/32	1 1/2	1	4 1/2	3/4	2 1/4	1	1 3/8
15-YSB-219-3-4	5.4	3 13/16	21/32	2	1 3/8	5	7/8	3	1 1/8	2
15-YSB-219-3-5	7.0	4 15/16	29/32	2 1/2	1 3/4	6 1/2	7/8	3 1/8	1 3/4	2 1/8

(Includes spacers to allow swivel action up to 7° and to make dimensions interchangeable with standard eye bracket.)

NOTE: To assure precision fit-up, pivot pins, machined to special tolerances are furnished with all swivel eye brackets, unless otherwise specified.



ROD END COUPLER AND WELD PLATE

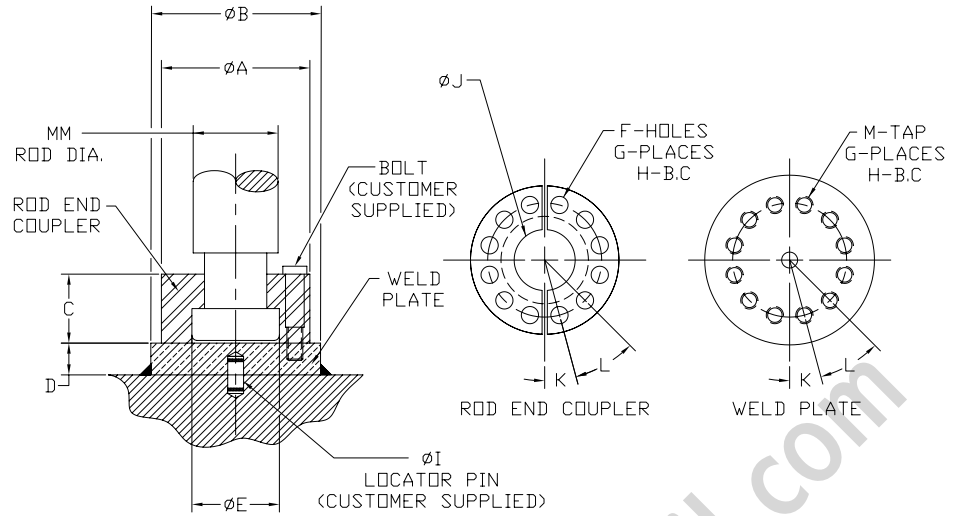

ROD END COUPLER PART#	WELD PLATE PART#	WELD PLATE MATERIAL	MM	DIMENSIONS												
				A	B	C	D	E	F	G	H	I	J	K	L	M
18-FEC-062	18-FEC-062-WP	CD 1018	5/8	1.500	2.000	.562	.500	.656	.218	4	1.125	250	.406	45°	90°	10-24
18-FEC-100	18-FEC-100-WP	CD 1018	1	2.000	2.500	.875	.500	1.063	.281	6	1.500	250	.750	30°	60°	1/4-20
18-FEC-137	18-FEC-137-WP	CD 1018	1 3/8	2.500	3.000	1.000	.625	1.438	.343	6	2.000	250	.938	30°	60°	5/16-18
18-FEC-175	18-FEC-175-WP	CD 1018	1 3/4	3.000	4.000	1.250	.625	1.813	.343	8	2.375	250	1.187	22.5°	45°	5/16-18

MALE SPHERICAL ROD EYE

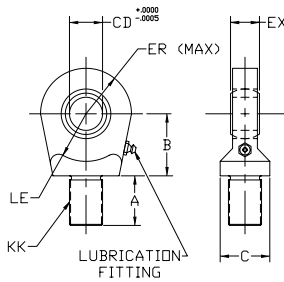

PART NUMBER	CD	KK	A	B	C	ER	EX	LE	MAX LOAD
13-MSRE-0500	.5000	7/16-20	11/16	7/8	7/8	7/8	7/16	3/4	2,600
13-MSRE-0750	.7500	3/4-16	1	1 1/4	1 5/16	1 1/4	21/32	1 1/16	7,080
13-MSRE-1000	1.000	1-14	1 1/2	1 7/8	1 1/2	1 3/8	7/8	1 7/16	12,590
13-MSRE-1375	1.3750	1 1/4-12	2	2 1/8	2	1 13/16	1 3/16	1 7/8	22,930
13-MSRE-1750	1.7500	1 1/2-12	2 1/8	2 1/2	2 1/4	2 3/16	1 17/32	2 1/8	38,220

SPHERICAL CLEVIS EYE BRACKET

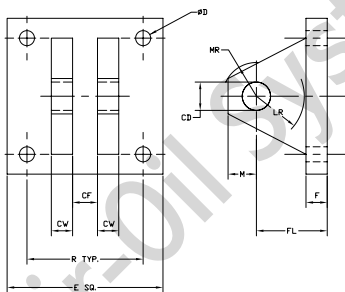

PART NUMBER	CD	CF	CW	D	E	F	FL	M	MR	LR	R
14-YCB-133-03-CBS	.500	.44	.50	.41	.300	.50	1.50	.50	.62	.94	205
14-YCB-133-05-CBS	.750	.66	.62	.53	3/75	.62	2.00	.88	1.00	1.38	276
14-YCB-133-06-CBS	1.000	.88	.75	.53	.550	.75	2.50	1.00	1.19	1.69	4.10
14-YCB-133-08-CBS	1.375	1.19	1.00	.66	6.50	.88	3.50	1.38	1.62	2.44	4.95
14-YCB-133-10-CBS	1.750	1.53	1.25	.91	8.50	1.25	4.50	1.75	2.06	2.88	6.58

SPHERICAL PINS

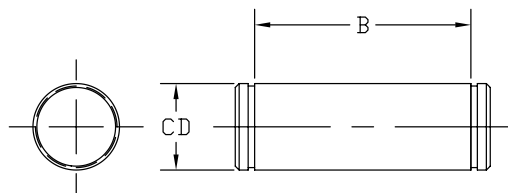

PART NUMBER	CD	B	
12-YP-9003-3-G-CBS	.4997	+0.000 -0.004	1 9/16
12-YP-9004-3-G-CBS	.7497	+0.000 -0.005	2 1/32
12-YP-9006-3-CBS	.9997	+0.000 -0.005	2 1/2
12-YP-9008-3-CBS	1.3746	+0.000 -0.006	3 5/16
12-YP-9010-3-CBS	1.7496	+0.000 -0.006	4 7/32



SELECTING THE CYLINDER

To select the proper size cylinder for the job, you must first determine the maximum push and/or pull force needed to accomplish its task.

Add an additional 10% to both the push and pull force for friction in the cylinder and also pressure drop in the lines. Using the charts below, select the proper bore and rod combination to best suit your application.

	A2, H2, A4, L4, H4, AND H6 BORE DIAMETER IN INCHES														
	1 1/2"	2"	2 1/2"	3 1/4"	4"	5"	6"	7"	8"	10"	12"	14"	16"	18"	20"
PISTON AREA (Square inches)	1.77	3.14	4.91	8.30	12.57	19.64	28.27	38.49	50.26	78.54	113.10	153.94	201.06	254.46	314.59

Multiply piston area by line pressure to calculate cylinder push force (thrust).

	A2, H2, A4, L4, H4, AND H6 BORE DIAMETER IN INCHES															
	5/8"	1"	1 3/8"	1 3/4"	2"	2 1/2"	3"	3 1/2"	4"	4 1/2"	5"	5 1/2"	7"	8"	9"	10"
ROD AREA (Square inches)	.31	.79	1.49	2.41	3.14	4.91	7.07	9.62	12.57	15.90	19.63	23.76	38.48	50.27	63.62	78.54

Subtract rod area from piston area and multiply by line pressure to calculate cylinder pull force (thrust).

PNEUMATIC AND FLUID POWER FORMULAS

FORMULA FOR:	EXPLANATION	FORMULA
FLUID PRESSURE <i>Pounds/Square Inch</i>	PRESSURE = $\frac{\text{FORCE (Pounds)}}{\text{UNIT AREA (Square Inches)}}$	P = $\frac{F}{A}$ OR PSI = $\frac{F}{A}$
CYLINDER PISTON AREA <i>Square Inches</i>	AREA = $\pi \times \text{RADIUS}^2 (\text{Inches})$	A = πr^2
CYLINDER OUTPUT FORCE <i>Pounds, Push or Pull</i>	FORCE = PRESSURE (psi) x NET AREA (Square Inches)	F = psi x A or F=PA
CYLINDER VELOCITY OR SPEED <i>Feet/Second</i>	VELOCITY = $\frac{231 \times \text{FLOW RATE (GPM)}}{12 \times 60 \times \text{NET AREA (SQUARE INCHES)}}$	V = $\frac{231Q}{720A}$ OR V = $\frac{.3208Q}{A}$
CYLINDER VOLUME CAPACITY <i>Gallons of Fluid</i>	VOLUME = $\frac{\text{PISTON AREA (Square Inches)} \times \text{STROKE (Inches)}}{231}$	V = $\frac{AL}{231}$ OR $\frac{\text{Length of Stroke}}{231}$
CYLINDER FLOW RATE <i>Gallons Per Minute</i>	FLOW RATE = $\frac{12 \times 60 \times \text{VELOCITY (Feet/Sec.)} \times \text{NET AREA (Square Inches.)}}{231}$	Q = $\frac{720vA}{231}$ OR Q = 3.117vA
PUMP OUTLET FLOW <i>Gallons/Minute</i>	FLOW = $\frac{\text{RPM} \times \text{PUMP DISPLACEMENT (Cu. In.Rev.)}}{231}$	Q = $\frac{nd}{231}$
PUMP INPUT POWER <i>Horsepower Required</i>	HORSEPOWER INPUT = $\frac{\text{FLOW RATE OUTPUT (GPM)} \times \text{PRESSURE}}{1714 \times \text{EFFICIENCY (Overall)}}$	HP_{IN} = $\frac{QP}{1714\text{Eff}}$ OR $\frac{\text{GPM} \times \text{psi}}{1714\text{Eff}}$
FLOW RATE THROUGH PIPING <i>Ft./Sec. Velocity</i>	VELOCITY = $\frac{.3208 \times \text{FLOW RATE THROUGH I.D. (GPM)}}{\text{INTERNAL AREA (Square Inches)}}$	V = $\frac{3208Q}{A}$
COMPRESSIBILITY OF OIL <i>Additional Required Oil To Reach Pressure</i>	ADDITIONAL VOLUME = $\frac{\text{PRESSURE (psi)} \times \text{VOLUME OF OIL UNDER PRESSURE}}{250,000}$	VA = $\frac{PV}{250,000}$ (APPROXIMATELY 1/2% Per 1,000 psi.)
AIR USAGE-CFM <i>In Cubic Feet Per Minute of Pressure Air (PSIG) Displaced Per Stroke</i>	CFM = Cyl. Piston Area Sq. In. x Cyl. Stroke In. x In./Min. Piston Speed $\frac{14.7 \times 1728}{14.7 \times 1728}$	CFM = $\frac{A \times \text{Stroke} \times \text{Speed}}{1728}$
FREE AIR USAGE (Output Volume of Free Air in Cubic Ft.) <i>Used to size a compressor</i>	FREE AIR (psia) = Cyl. Piston Area Sq. In. x Cyl. Stroke In. x In./Min. Piston Speed $\frac{14.7 \times 1728}{14.7 \times 1728}$	FA (Cu. Ft.) = $A \times \text{Stroke} \times (\text{Force} + 14.7) \frac{14.7 \times 1728}{14.7 \times 1728}$



SELECTING THE CYLINDER

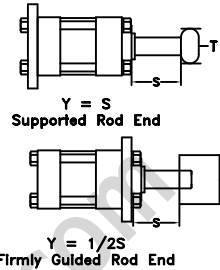
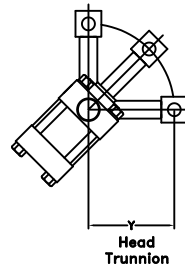
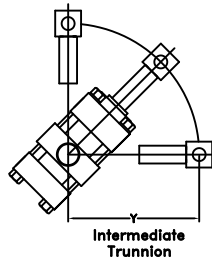
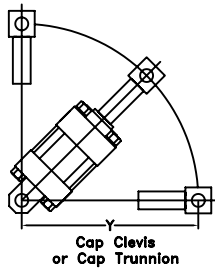
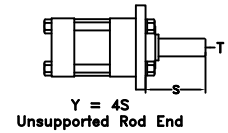
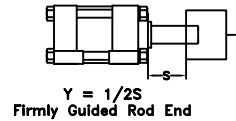
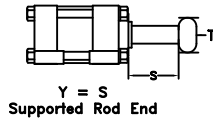
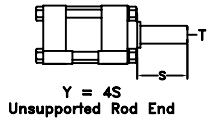

STOP TUBE

Stop tubes are installed between the piston and front head on long stroke cylinders. The stop tube lengthens the distance between the piston and the rod bearing and reduces load when fully extended. To determine if a stop tube is required and the length, first determine the value of "Y" from one of the illustrations above.

If "Y" is less than 40", no stop tube is needed. If "Y" is over 40", a one inch stop tube is recommended for every 10" or fraction thereof over 40". (see Chart 27-A)

ROD DIAMETER SELECTION

In most applications the standard rod size is suitable. On long stroke or high thrust applications, an over size rod may be required.

To arrive at the minimum rod size for your application, first determine the bore size, stroke, and thrust (See Page 106). Now select from the above illustration the type of mounting and determine the length "Y" with the piston rod in the fully extended position.

NOTE: "Y" or "S" are calculated from mounting point with rod extended.

CHART 27-A
STOP TUBE TABLE

"Y" (Inches)	Stop Tube Length (Inches)	"Y" (Inches)	Stop Tube Length (Inches)
0-40	0	101-110	7
41-50	1	111-120	8
51-60	2	121-130	9
61-70	3	131-140	10
71-80	4	141-150	11
81-90	5	151-160	12
91-100	6	161-170	13

Using Chart 27-B look for the maximum thrust for your cylinder, then look across for the "Y" length determined from the illustrations. If the exact value is not shown, continue to the next larger number. Now go to the top of the column and you will find the recommended rod size for your application.

CHART 27-B VALUE OF COLUMN LENGTH "Y" IN INCHES																
Thrust in lbs.	PISTON ROD DIAMETER															
	5/8"	1"	1 3/8"	1 3/4"	2"	2 1/2"	3"	3 1/2"	4"	4 1/2"	5"	5 1/2"	7"	8"	9"	10"
50	62															
100	55	112														
200	47	99														
250	43	94	146													
300	44	88	142													
400	37	83	134	186												
500	38	75	130	180												
700	30	68	118	168	202	275										
1,000	25	60	103	156	190	257	330									
1,400	24	53	92	142	174	244	308	385								
1,800	23	48	82	127	160	230	296	366	440							
2,400	19	45	75	114	145	213	281	347	415	488						
3,200	16	41	67	103	130	194	261	329	400	461						
4,000	12	31	62	96	119	175	240	310	378	446						
5,000	9	34	60	87	110	163	225	289	360	426	494					
6,000	5	30	56	82	102	152	208	274	342	410	476					
8,000	5	22	45	75	93	137	188	245	310	375	447					
10,000	4	21	40	67	89	125	172	222	279	349	412	482				
12,000	3	17	41	65	84	118	155	210	269	326	388	454				
16,000		9	34	57	75	110	142	188	235	292	350	420				
20,000			27	48	68	103	136	172	218	270	326	385				
30,000			12	40	55	87	120	156	189	230	285	330				
40,000				22	43	74	108	142	177	210	248	294				
50,000				15	30	66	96	130	165	200	234	269	408			
60,000					18	57	88	119	154	190	225	256	384			
80,000					16	36	71	104	137	170	204	240	336			
100,000						22	57	90	120	154	189	222	324	400		
120,000						21	45	77	108	140	175	207	313	377		
140,000						19	27	64	98	128	160	194	301	365		
160,000							26	47	86	118	148	182	279	350	421	
200,000								31	67	98	131	161	260	330	402	
250,000								28	36	72	109	141	236	301	375	
300,000								25	34	42	86	120	212	281	351	420
350,000										39	52	100	195	261	328	396
400,000											45	77	182	241	309	374
500,000											41	49	152	212	274	341
600,000												45	114	183	247	310
700,000													70	162	221	280
800,000													63	118	197	260



TYPES OF CYLINDERS

DOUBLE ACTING CYLINDERS

This is the most common type of cylinder. This type of cylinder is for use in applications where force is needed in both directions.

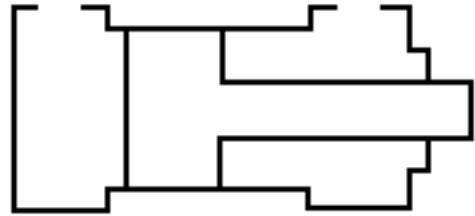

SINGLE ACTING CYLINDERS

This type of cylinder is used when force is needed in only one direction either extend or retract. Commonly the opposite end of the cylinder is vented to atmosphere, or in a hydraulic application the opposite port can be vented back to the tank. Depending on the application either gravity or the weight of the load will retract the cylinder

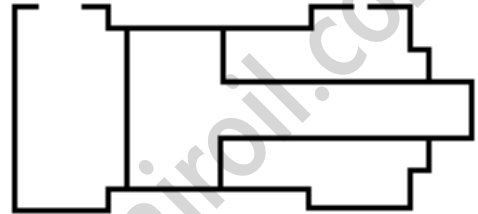

DOUBLE ROD CYLINDERS

These cylinders can have load attached to both ends of the cylinder and work in both directions. Other applications for double rod cylinders include equal displacement on both sides of the cylinder, or operating switches of cams.

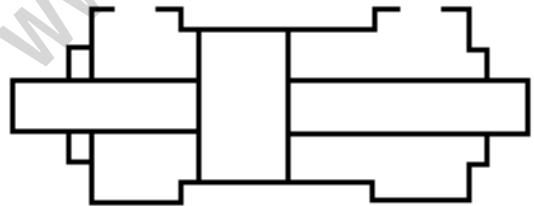

SPRING CYLINDERS

Spring cylinders have a spring built inside to extend, retract, or center the cylinder on its own or to assist pneumatic or hydraulic pressure. These cylinders are commonly used as clamp cylinders. Note that the addition of a spring can increase the length of a cylinder as much as 3 times or more.

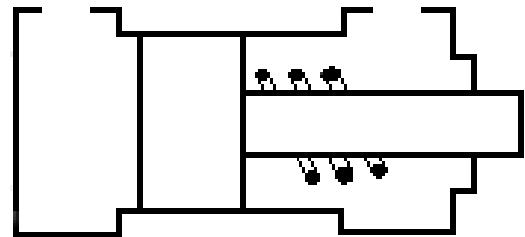

RAM CYLINDERS

Ram cylinders are commonly known as displacement cylinders. Mainly used for long strokes where gravity or the weight of the load can retract the cylinder and are almost always mounted vertically.

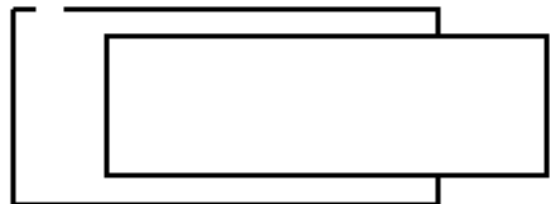

TYPES OF CYLINDERS

TELESCOPIC CYLINDERS

Telescopic cylinders are commonly used in mobile equipment and machinery. The multiple “stages” of the cylinders allow applications to get long strokes with short retracted lengths and are available in single or double acting configurations

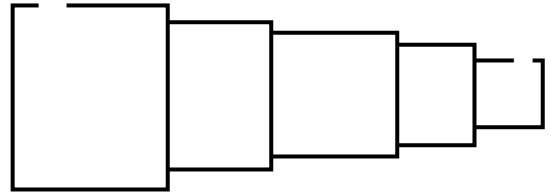

TANDEM CYLINDERS

Tandem cylinders consist of two cylinders mounted in line together with one piston rod connecting both pistons together with one working rod end to gain increased output forces while having a compact

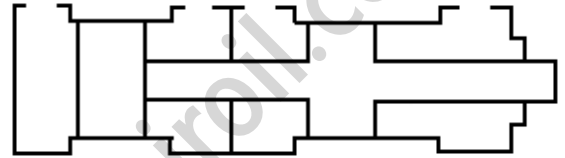

DUPLEX CYLINDERS

Duplex cylinders are sometimes known as three position cylinders. They consist of two cylinders mounted inline together without having the pistons connected together by one common piston rod.

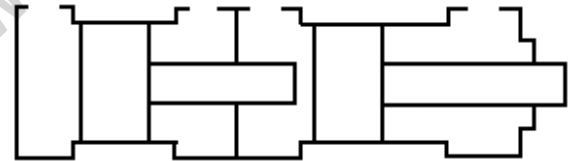

BACK TO BACK CYLINDERS

Back to back cylinders consist of two cylinders mounted together on the cap or blind end. This lets both cylinders act separately from each other or together as in a double rod cylinder application.



ADJUSTABLE STROKE CYLINDERS

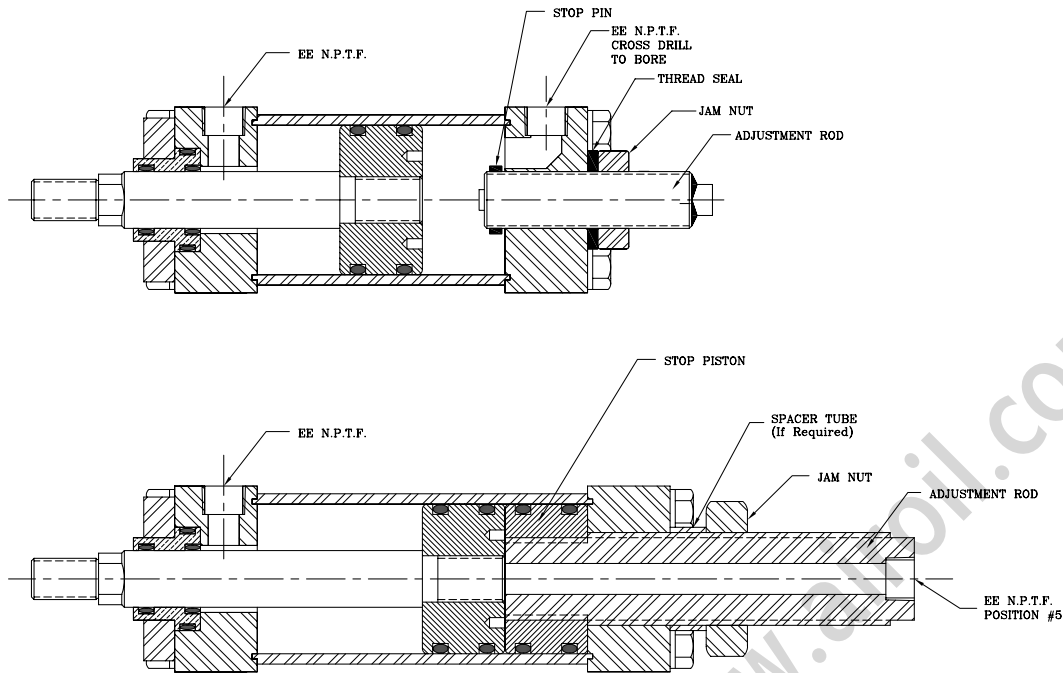

ORDERING INSTRUCTIONS

For style #1 adjustable stroke cylinders, adjustment stroke available up to a maximum of 6".

For Style #2 adjustable stroke cylinders, a stop piston is furnished to allow full face, piston-to-piston contact and to allow stability for longer strokes.

When ordering Adjustable Stroke Cylinders, complete the part number then place an "S" in the part number. Under specials, specify length of adjustment and type of adjustable stroke (Style #1 or Style #2) and any other required specials.

- Available in all Yates series cylinders.
- A longer spacer tube may be required on L & N mounts for style # 2.
- Cushions not available at cap end.
- Not available in double rod cylinders.
- Other designs are available based on application needs. For adjustable stroke cylinders that require frequent adjustment, contact factory for details.
- Available with an extended key plate.

AVAILABLE MOUNTING STYLES		
STYLE	NAME	N.F.P.A. CODE
A*	SIDE LUGS	MS2
B*	SIDE TAPPED	MS4
F	HEAD RECTANGULAR FLANGE	MF1
G	HEAD RECTANGULAR INTEGRAL FLANGE	ME5
H	CENTER-LINE LUGS	MS3
J	HEAD SQUARE FLANGE	MF5
X	HEAD INTEGRAL FLANGE	ME3
K	NO TIE RODS EXTENDED	MX0
L	BOTH ENDS TIE RODS EXTENDED	MX1
M	HEAD TIE RODS EXTENDED	MX3
N	CAP TIE RODS EXTENDED	MX2
U	HEAD TRUNNION	MT1
W	CAP TRUNNION	MT2
T	INTERMEDIATE FIXED TRUNNION	MT4

PROXIMITY SWITCHES

FEATURES AND OPTIONS

- Factory installation. No adjustments needed.
- Hydraulic rating up to 3,000 psi.
- Stainless steel probe
- Led indicators
- False pulse protection
- UL listed
- Shock and vibration resistant
- Weld Field and electrical noise immunity
- Series and parallel wiring
- Rotatable switches to ease cable routing
- Optional intrinsically safe
- Optional hi temp up to 400°F (204°C)
- Optional underwater service to 2,000 foot depths
- Optional Explosion proof
- Optional Solid state operation
- Optional Heavy duty operation up to 5,000 psi.

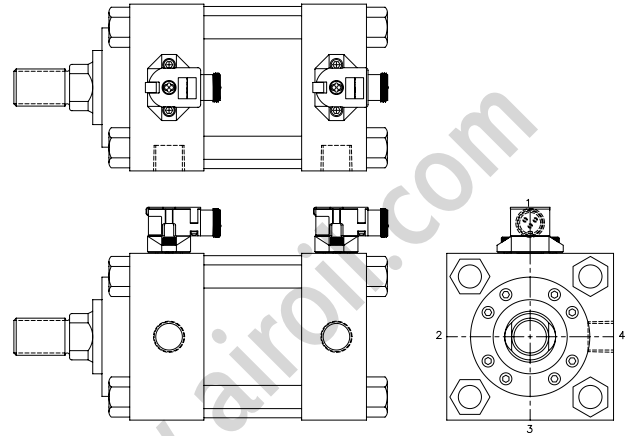

Yates Prox Switch option is available on A4, L4, H4 and H6 series cylinders.

COMMON SENSOR CHARACTERISTICS	AC	DC
NOMINAL SENSING RANGE (+/-10%)		0.080"
CURRENT CONSUMPTION	1.7 OR 4.5MA	10MA
VOLTAGE DROP	=10 VAC	2.0V @ 100MA
TEMPERATURE DRIFT (MAX.)		+/-10%
SHORT CIRCUIT PROTECTION		YES
REVERSE POLARITY PROTECTED		YES
AMBIENT TEMPERATURE RANGE		-4°F TO +158°F
MAXIMUM SWITCHING FREQUENCY		16HZ
HYSTERESIS		3-10%
REPEATABILITY		<+/-1.25%
NEMA ENCLOSURE TYPE RATED		4, 6, 12 & 13
LOAD CURRENT	5MA TO 500MA	200MA MAX.
LED INDICATOR	RED=POWER/GREEN=TARGET	GREEN=POWER/AMBER=TARGET



REED & HALL EFFECT SWITCH DATA

Yates Cylinders Reed and Hall effect Switches are Designed for use on all types of cylinders with aluminum and non-ferrous barrels. A magnetic band is installed on the cylinder's piston which the Reed and Hall effect switches read, through the non ferrous cylinder barrel. The switches then send a signal to programmable controllers and other various electrical circuits.

YATES CYLINDERS REED SWITCH FEATURES:

- Available for 1 1/2" bore through 8" bores.
- Easy to adjust switch bracket, mounts to tie rod of cylinder and can be adjusted anywhere along entire stroke.
- Multiple switches may be used on one cylinder to control or sequence several functions.
- LED indicator light for trouble shooting and easy installation.
- Voltage range of 5 to 240 VAC/VDC. (Normally Open)
- 9' Wire Lead is standard.
- Economical sensing solution.
- Zero maintenance.

Part Number	(1 1/2" Bore Only)	(2"-8" Bores)
	YRS-015	YRS-028
Switch Type	Reed Switch MOV & LED	Reed Switch MOV & LED
Function	Normally Open	Normally Open
Working Temp.	-30C - +80C	-30C - +80C
Magnetic Sensitivity	85 GA.	85 GA.
Switching Voltage	5-120 VAC/VDC 50/60 Hz	5-240 VDC/VAC
Switching Current	.5 Amps Max. .005 Amp Min.	1 Amp Max. .005 Amp Min.
Switching Power	10 Watts Max.	30 Watts Max.
Voltage Drop	3.5 Volts	3 Volts

YATES CYLINDERS HALL EFFECT SWITCH FEATURES:

- Available for 1 1/2" to 8" bores.
- Easy to adjust switch bracket, mounts to tie rod of cylinder and may be adjusted anywhere along the entire stroke.
- LED indicator light for trouble shooting and easy installation.
- Solid state construction- No moving parts to wear out which provides longer switch life.
- Voltage range of 6-24 VDC
- Available normally open, sinking or sourcing
- 9' wire lead is standard.
- Voltage range of 5 to 240 VAC/VDC. (Normally Open)
- 9' Wire Lead is standard.
- Economical sensing solution.
- Zero maintenance.

Part Number	1 1/2" Bore Only YHS-015-1	1 1/2" Bore Only YHS-015-2	2"-8" Bores YHS-028-1	2"-8" Bores YHS-028-2
Switch Type	Hall Effect LED Sourcing	Hall Effect LED Sinking	Hall Effect LED Sourcing	Hall Effect LED Sinking
Function	Normally Open	Normally Open	Normally Open	Normally Open
Working Temp.	-30°C - +80°C	-30°C - +80°C	-30°C - +80°C	-30°C - +80°C
Magnetic Sensitivity	85 GA.	85 GA.	85 GA.	85 GA.
Switching Voltage	6-24 VDC	6-24 VDC	6-24 VDC	6-24 VDC
Switching Current	.5 Amp Max.	.5 Amp Max.	1 Amp Max.	1 Amp Max.
Switching Power	12 Watts Max.	12 Watts Max.	24 Watts Max.	24 Watts Max.
Voltage Drop	.5 Volts	.5 Volts	.5 Volts	.5 Volts

REED & HALL EFFECT SWITCH DATA

YATES SWITCH INSTALLATION TIPS:

1. Never exceed the current and voltage of the load with the selected switch. Failure to use proper load will ruin the switch. For DC Voltages always observe polarity.
2. On two-wire versions, do not connect directly across the power supply without a series load. Failure to use a series load will damage the switch and possibly the power supply.
3. Never use a filament light bulb as a load test to the switch. Severe inrush currents will damage the switch or cause premature failure.
4. Keep wire runs to a minimum. Longer wire runs will increase capacitive loading which may effect the life of the switch.
5. When actuating a solenoid with a switch, always use an external surge suppression.
6. At all times keep the area around the switch clean and free of potentially magnetic debris.
7. Be sure the sensing area of the switch is installed against the cylinder tube.
8. Consult factory if you have any additional questions regarding Reed and Hall Effect switches.

SWITCH & BRACKET FOR 1 1/2" BORE

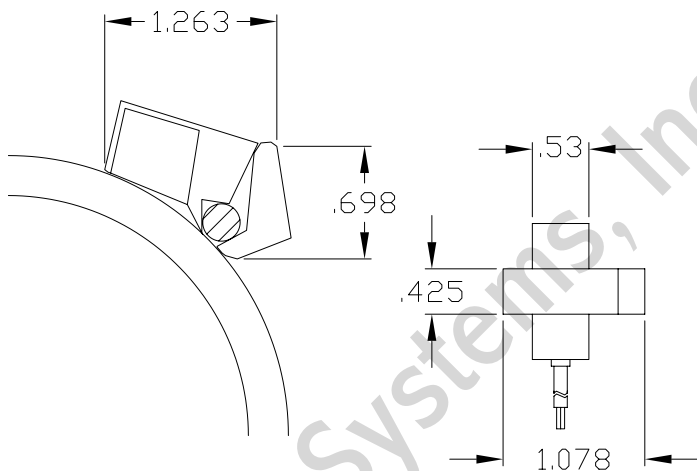

SWITCH & BRACKET FOR 2-8" BORE

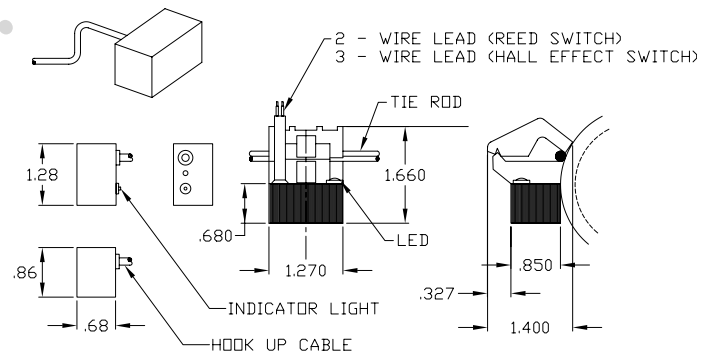

YHS-028-1

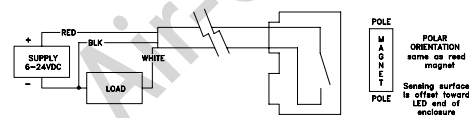

YHS-028-2

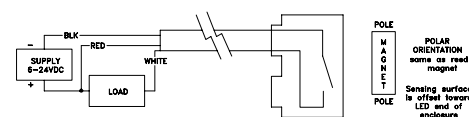

YHS-015-1

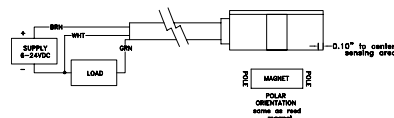

YHS-015-2

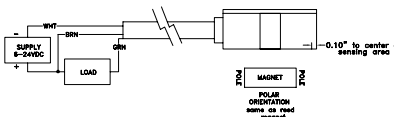

YHS-015

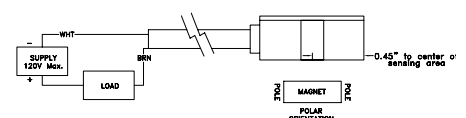

YHS-0028

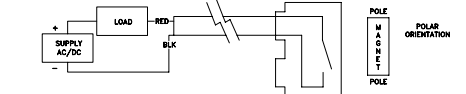

LDT

MAGNETOSTRICTIVE LINEAR DISPLACEMENT TRANSDUCER FOR HIGH SHOCK AND VIBRATION APPLICATIONS.

Standard LDT is lab tested and field proven to survive high shock and vibration. With tested results of 2,000 G's of shock and 30 G's of random vibration with no false signals or mechanical damage , it can survive in the most rugged and demanding applications.

Sensing tube construction is welded stainless steel, suitable for 5000 PSI hydraulic cylinders. The electronics are enclosed inside an aluminum housing with o-ring seals for IP67 indoor applications. Type NEMA 6 rating and stainless steel housings and connectors are available as a special option.

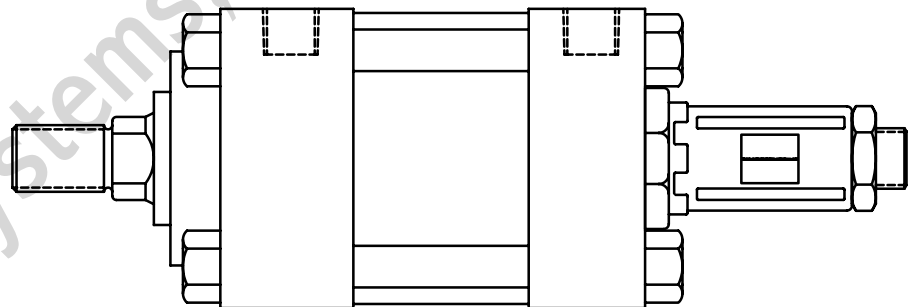
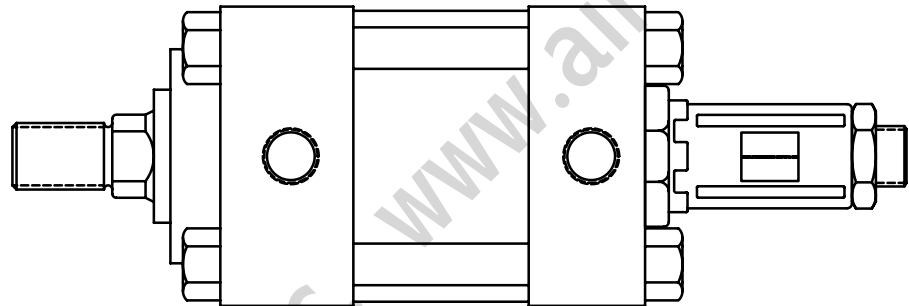
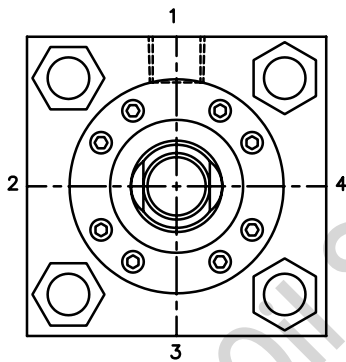

LDT ELECTRICAL INFORMATION

INPUT VOLTAGE	15 VDC to 26 VDC
CURRENT DRAW	<200 mA at 15 VDC
OUTPUT	
ANALOG	Absolute Analog Position via Digital-to-Analog Converter -10 to 10 VDC 16-Bit (65,535) Resolution 0 to 10 VDC 15-Bit (32,768) Resolution -5 to 5 VDC 15-Bit (32,768) Resolution 0 to 5 VDC 14-Bit (16,384) Resolution 4 to 20 mA 16-Bit (65,535) Resolution
DIGITAL	TTL Level Pulse/Pulse, RS422 Pulse/Pulse RS422 Pulse Width Modulated
RESOLUTION	
INTERNAL	.001"
ANALOG OUTPUT	16-Bit (one part in 65,535)
NON-LINEARITY/ ACCURACY	Less than 0.05% of Full Stroke with +/-0.002" (+/-0.05 mm) Maximum
REPEATABILITY	+/- 0.001% of Full Scale or +/-0.0004" (0.102 mm) Maximum
HYSTERESIS	.001" (.025 mm) Maximum
OPERATING TEMPERATURE	
HEAD ELECTRONICS	-40° to 155°F (-40° to 70° C
GUIDE TUBE	-40° to 220°F (-40° to 105° C)
OPERATING PRESSURE	5000 psi Operational, 10,000 psi Spike
SPAN LENGTH	1" - 300"
NULL ZONE	1.5"
DEAD ZONE	2.25"
CONNECTORS	1/4 Turn MS Style Connector Standard Potted Pigtail Assembly Available Optionally
UPDATE TIME	2 MS Typically
ENCLOSURE	IP67

**SPECIFICATIONS ARE SUBJECT TO CHANGE WITHOUT NOTICE.
 OTHER OPTIONS AVAILABLE. CONSULT FACTORY.**

AIR OIL TANKS

Yates air/oil tanks are used to obtain smooth hydraulic pressure without the high cost of hydraulic systems. Shop air pressure is applied into the top of the air/oil tanks and then dispenses the oil into the work cylinder. The hydraulic pressure generated is in a 1 to 1 ratio. 80 PSI shop air produces 80 PSI hydraulic pressure (see figure 25-1)

BORE SIZES: 3 1/4 **PRESSURES:** up to 200 PSI

CONSTRUCTION AND FEATURES:

- Lightweight aluminum end caps
- High-strength fiberglass tube is also translucent and provides oil level indication without the use of expensive sight gauges
- Two air/oil baffles, one installed on both end caps eliminates oil foaming and provides smooth oil flow into the work cylinder
- Tube and O-ring seal, positively seals end caps to tube
- Side end angle mounts come standard (other mounts available)

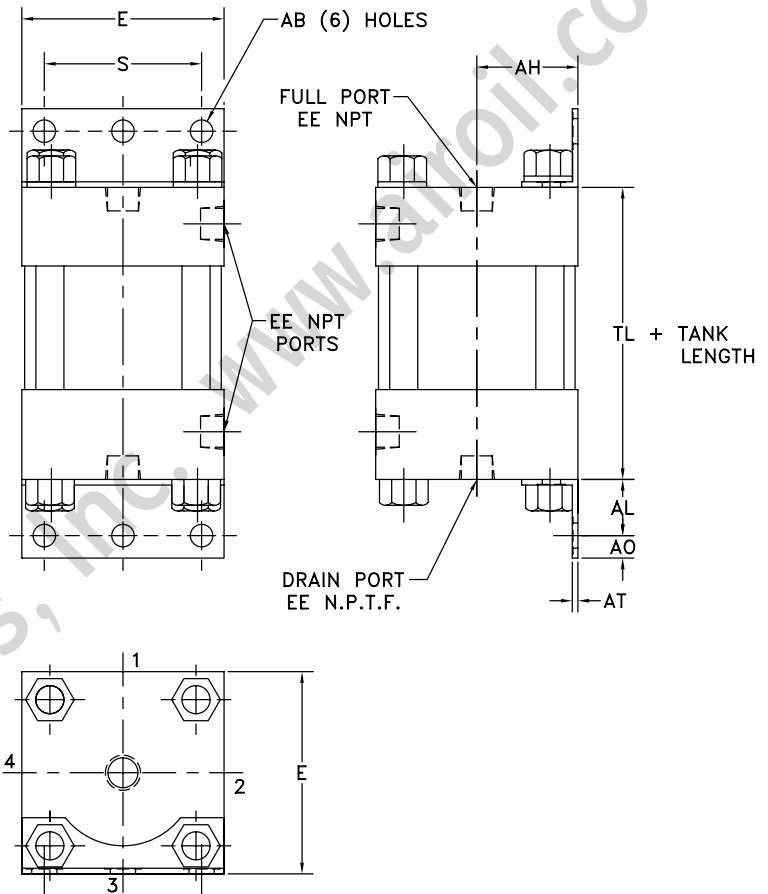

BORE	TANK DIMENSIONS									
	E	J	S	AB	AH	AL	AO	AT	EE	TL
3 1/4	3 3/4	1 1/4	2 3/4	1/2	1 15/16	1 1/4	1/2	1/8	1/2	2 1/2
4	4 1/2	1 1/4	3 1/2	1/2	2 1/4	1 1/4	1/2	1/8	1/2	2 1/2
5	5 1/2	1 1/4	4 1/4	5/8	2 3/4	1 3/8	5/8	3/16	1/2	2 1/2
6	6 1/2	1 1/2	5 1/4	3/4	3 1/4	1 3/8	5/8	1/4	3/4	3
8	8 1/2	1 1/2	7 1/8	3/4	4 1/4	1 7/16	11/16	1/4	3/4	3

AIR OIL TANKS

SELECTING THE AIR/OIL TANKS

1. Determine the volume of oil necessary to fill the work cylinder when at full stroke. This can be determined by multiplying the piston area by the stroke length.
2. Next select the bore and tank length from Chart 25-2 which is equal to or greater than the volume determined in step 1

NOTE: Smaller bore size with longer length are generally more economical than larger bores with shorter lengths.

WHEN ORDERING SPECIFY: Quantity, mounting, bore and length

FIGURE 25-1

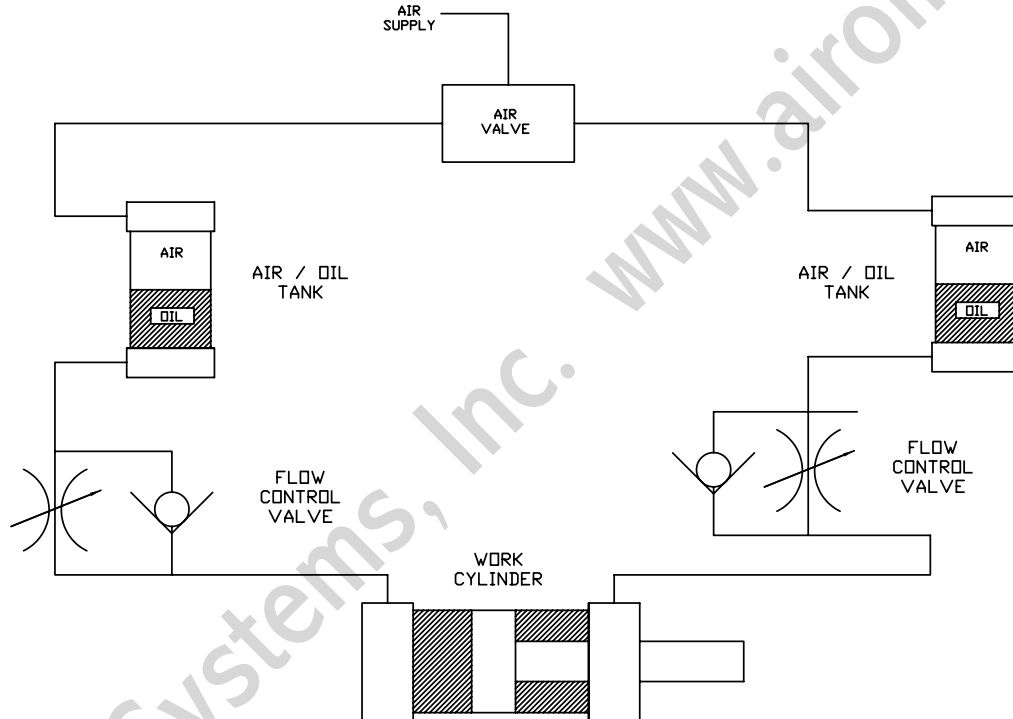
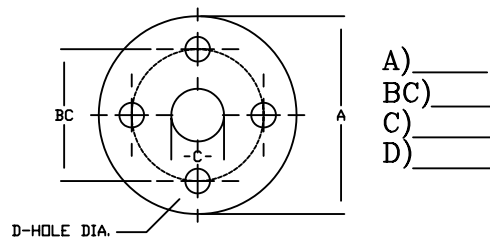
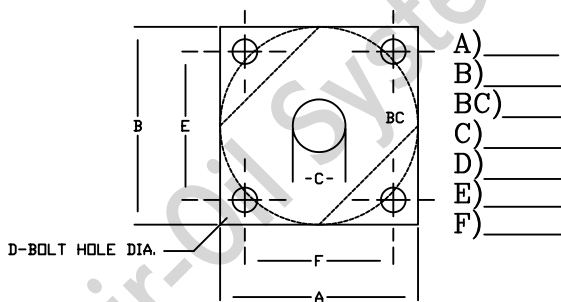
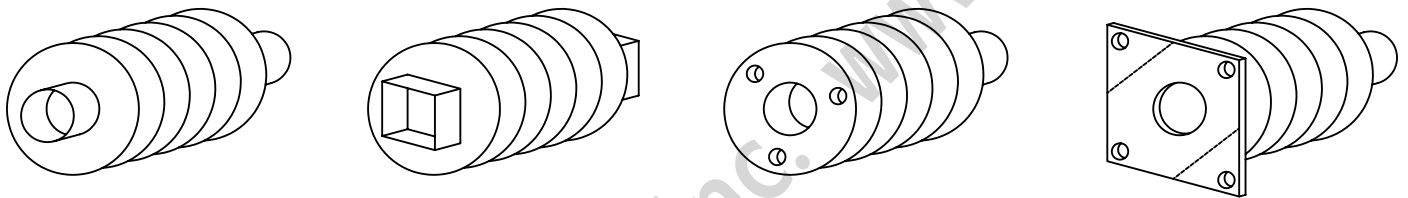
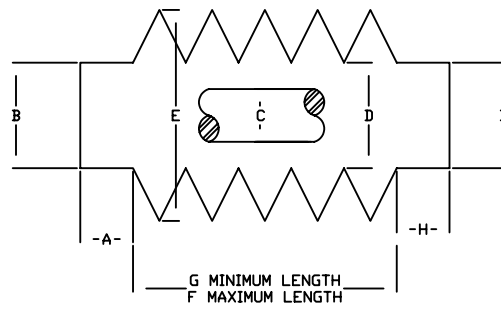

CHART 25-2

BORE	TANK LENGTH (INCHES)														
	6	7	8	9	10	11	12	13	14	15	16	17	18	19	20
3 1/4	25	32	39	46	53	60	68	75	82	90	97	104	111	119	126
4	37	48	59	70	81	92	104	115	126	137	149	160	171	182	194
5	56	73	90	107	124	142	159	176	193	211	229	246	263	282	299
6	81	106	131	156	181	206	231	256	281	306	332	357	382	407	432
8	145	190	235	280	324	368	412	456	500	544	588	634	678	724	768

ROD BOOT



ROD BOOT

ORDERING INSTRUCTIONS

When ordering rod boots with a cylinder, under "specials" state that "S" equals rod boot along with any additional specials that may be required. Complete the rod boot order form and return with cylinder specifications, to your Yates Cylinders sales representative.

When ordering a rod boot without a cylinder, complete the rod boot order form and return to your Yates Cylinders sales representative.

ROD BOOT ORDER FORM

- A) Length of Cuff _____
- B) Inside Diameter of Cuff _____
- C) Rod Diameter _____
- D) Inside Diameter of Boot _____
- E) Max. Outside diameter of Boot _____
- F) Max. Length Excluding Cuff _____
- G) Min. Length Excluding Cuff _____
- H) Length of Cuff _____
- I) Inside Diameter of Cuff _____

QUANTITY: _____

Please check box for material specification:

- | | |
|--|--|
| <input type="checkbox"/> Neoprene-Coated Nylon .022" thick -60°F to +250°F | <input type="checkbox"/> Neoprene-Coated Nylon .033" thick -60°F to +250°F |
| <input type="checkbox"/> PVC-Coated Nylon .022" thick -20°F to +180°F | <input type="checkbox"/> Aluminized Fiberglass .025" thick -100°F to +650°F |
| <input type="checkbox"/> Hypalon-Coated Nylon .022" thick -60°F to +350°F | <input type="checkbox"/> PTFE-Coated Fiberglass .018" thick -100°F to +550°F |

Please circle style end type:

Round Cuff Square Cuff Round Flange Style Square Flange Style

Phone: (586) 778-7680

Fax: (586) 778-6565

Email: sales@yatesind.com



OPERATING FLUIDS AND SEALS

STANDARD SEALS

Standard seals are what is normally provided unless otherwise specified. Seals provided are generally Nitrile intended for use with: air, mineral based hydraulic oils, nitrogen within normal operating temperatures of -10°F to +165°F. P.T.F.E. back ups are used where required.

FLUOROCARBON SEALS

Provided when higher temperature service is intended. Used with some Phosphate Ester fluids (with exception of Skydrols) and many fire resistant formulas. Fluorocarbon seals can be operated within -10°F to +250°F. They may also be used to +400°F with shorter seal life expectancy. For applications over +250°F cylinders must be ordered with the piston set screwed to piston rod. P.T.F.E. back ups will be provided as needed.

HI-LOAD SEALS

Seal combination of one or two bronze filled Teflon rings with elastomer expander underneath, with a pair of wear bands on the outer edges. This configuration is virtually leak free under static conditions and compatible with high pressures. The configuration is also capable of handling high side load applications.

CAST IRON PISTON RINGS

Offering the widest operating conditions in temperatures pressures and fluids this configuration can be used in many applications. Note: cast iron rings do allow a small amount of bypass that increases with bore size and pressures used.

LOW FRICTION OR NON-LUBED SEALS

Standard for the A2/H2 series and suitable for most low friction applications the standard lip seal piston seals and rod seals are offered in Carboxylated nitrile with Teflon® compound ensuring low friction and long seal life in both lubed and non-lubed applications.

MOUNTING CONSIDERATIONS

Yates Industries fluid power cylinders can be found in many mounting configurations. The decision on the proper mount should take into effect what style is best suited for the application at hand. We can break these mounts into 3 groups:

CENTERLINE FORCE TRANSFER (Mounts include F,R,G,P,J,S,X,Z,K,L,M,N)

These are cylinders with fixed mounts that absorb forces along their center line in both thrust and tension applications. Mounting bolts are not subjected to compound forces and if properly installed sideload damage is removed extending rod gland life.

OFF CENTERLINE FORCE TRANSFER (Mounts include A, B, E & Y)

These are cylinders with fixed mounts that do not absorb forces along their centerline. These mounts tend to produce a twisting in the cylinder as it applies force to a load. To avoid problems these cylinders must be securely mounted with loads well guided when possible. Depending on application pinning the mounting lugs or adding an extended key plate may reduce side load to rod gland and piston bearings. Consult factory with questions or concerns with your application.

PIVOT FORCE CYLINDERS (Mounts include C, V, DC, DV, Q, U, T & W)

These cylinders absorb forces along their centerline and are used when the load must travel in a curved path. The type of mount will depend on the load staying in one curved path or the need to pivot on two axis. Choose the mount based on your application and consult the piston rod selection chart on page 107 for long stroke applications, a larger rod diameter or stop tube may be required.

CORROSIVE RESISTANT CYLINDERS

Water processing, food processing, marine, waste water treatment, etc.

STAINLESS STEEL CYLINDERS

- All external components manufactured from series 300 stainless steel
- Flash hard chrome plated stainless steel piston rod standard on all stainless steel cylinders. Available in 303 or 17-4 ph.
- An extra long, high strength bronze gland provides maximum bearing support and wear resistance.
- Electroless nickel plated, flush mounted captive cushion adjustment allows safe cushion adjustment under pressure
- One piece fine grained cast iron piston provides maximum strength and protection against shock loads (optional stainless steel piston with wear band)
- Pressure rated to 250 psi air service. Consult factory for hydraulic pressure service.
- Available in most mounting styles.

ELECTROLESS NICKEL PLATED CYLINDERS

- Electroless nickel plated cylinders are an economical alternative to stainless steel cylinders in many corrosive applications.
- All external components are electroless nickel plated (optional stainless steel fasteners are available depending on pressure rating)
- Chrome plated stainless steel piston rod standard on all electroless nickel plated cylinders.
- Available in most mounting styles.

ADDITIONAL CORROSIVE RESISTANT OPTIONS

- Epoxy paint (food grade, marine grade, etc.)
- Composite components available: heads, caps, pistons, tubes and glands.
- Nitrotec piston rods
- Black oxide of all external components

STATIC ROD LOCKS

Yates new YRL series rod locks offer the next generation in holding/locking devices with superior performance. These spring engaged, air-released rod locks supplement air cylinders and guide rods for holding in emergency stop or power off conditions. High pressure clamping forces ensure positive holding with minimal air required for lock release.

LONG LASTING PERFORMANCE

Designed for millions of trouble free cycles, the YRL rod lock offers a sealed design to withstand even the harshest wash down applications. Spring engaged design offers operation even in loss of power situations. The fast spring response also increases positioning accuracy.

BENEFITS

- No rod displacement
- Large clamping surface
- 2,000,000+ life cycles
- Sealed internal components
- Extremely low backlash
- NFPA sizes

APPLICATIONS

- Automation equipment
- Injection molding machines
- Hydraulic presses
- Machine tools
- Elevators/ scissor lifts

OPERATIONAL SPECIFICATIONS:

All YRL rod locks will operate in both directions, engaging with the same holding force. Rod locks can be mounted in any position. Rod rotation is not allowed when lock is engaged (not intended for torsional braking).

Release pressure can range from 60-120 psi.

Buna-N seals are rated to 212°F.

Operating temperatures range from 33°F-150°F. Units are capable of intermittent use at temperatures up to 212°F.



ROD LOCKS

CYLINDER MOUNTED

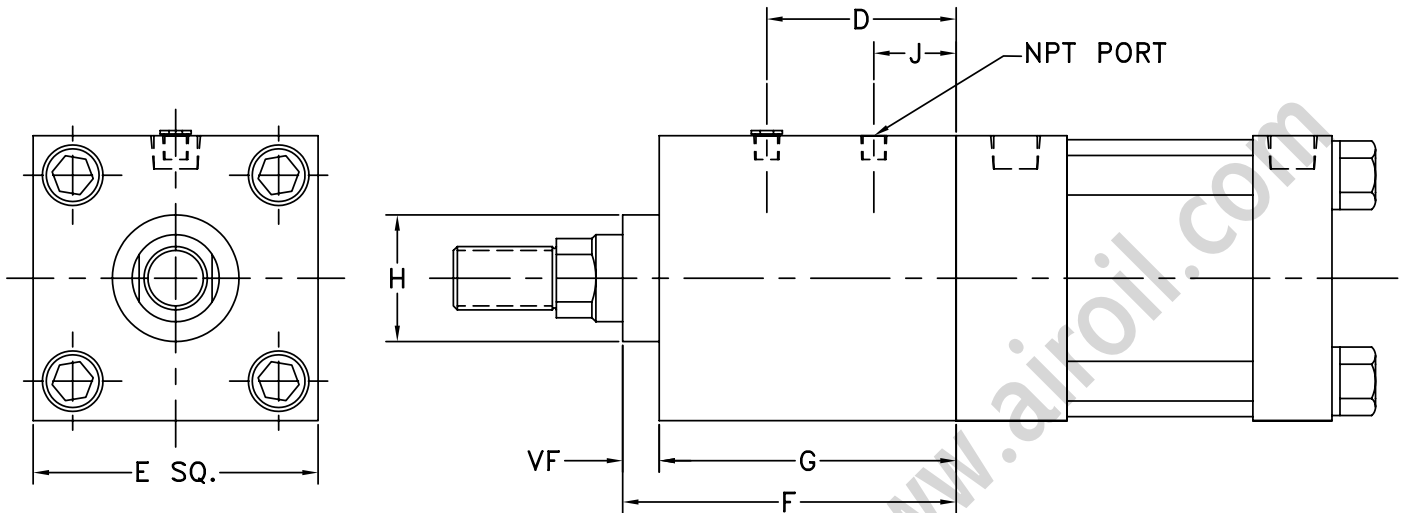

STAND ALONE

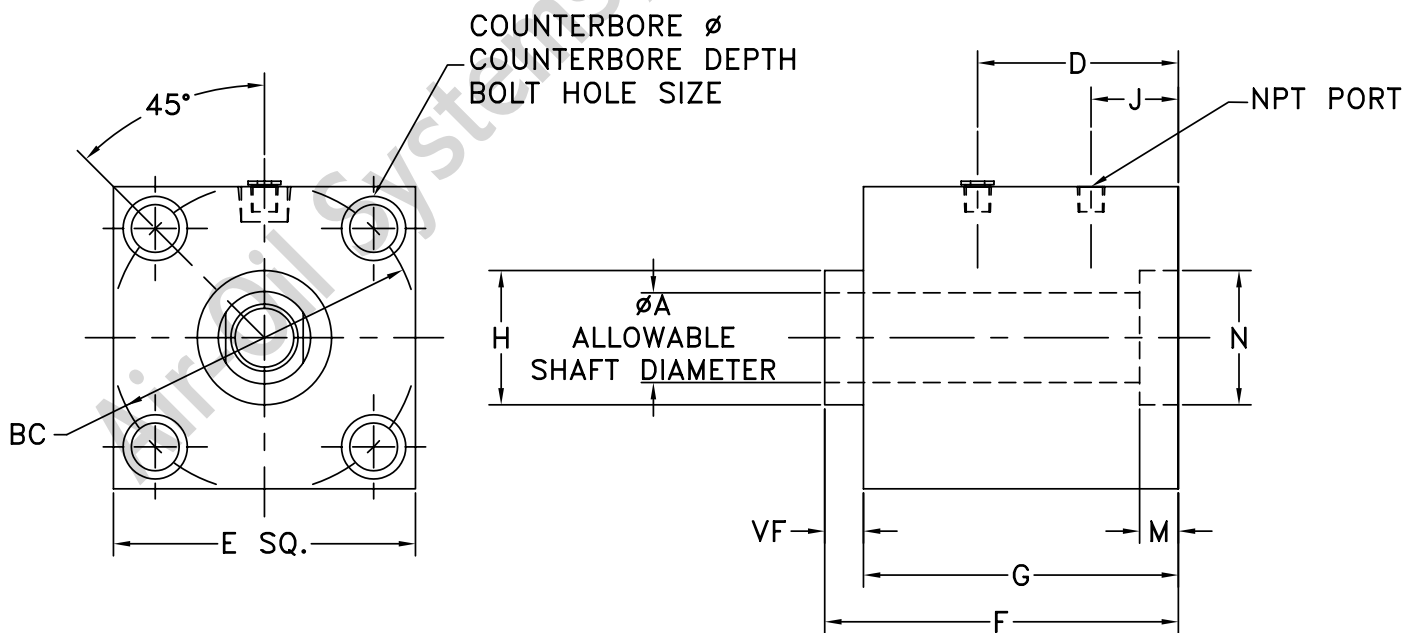

ROD LOCK DIMENSIONS

ROD LOCKS FOR NFPA CYLINDERS

MODEL#	ØA*	D	E	F	VF	G	ØH*	J	HOLDING FORCE	NPT Air Inlet
YRL-150-0625	0.625	1.95	2.00	2.77	0.375	2.397	1.125	0.91	180 LBS	1/8-27
YRL-200-0625	0.626	2.08	2.50	2.80	0.375	2.422	1.125	1.02	314 LBS	1/8-27
YRL-200-1000	1.000	2.58	2.50	3.88	0.500	3.375	1.500	1.58	325 LBS	1/8-27
YRL-250-0625	0.625	2.13	3.00	2.91	0.375	2.540	1.125	1.02	491 LBS	1/8-27
YRL-325-1000	1.000	2.99	3.75	4.48	0.500	3.976	1.500	1.56	830 LBS	1/4-18
YRL-400-1000	1.000	2.99	4.50	4.48	0.500	3.976	1.500	1.56	1300 LBS	1/4-18
YRL-400-1375	1.375	3.16	4.50	4.92	0.750	4.165	2.000	1.76	1300 LBS	1/4-18
YRL-500-1000	1.000	3.34	5.50	4.94	0.500	4.443	1.500	1.35	2000 LBS	1/4-18
YRL-600-1375	1.375	4.43	6.50	5.93	0.625	5.306	2.000	1.89	2850 LBS	1/4-18
*HØ -.001/-.003" AØ +.000/-.002"										

STAND ALONE ROD LOCK FOR GUIDE RODS

MODEL#	ØA*	B	ØBC	E	D	G	F	VF	ØH*	J
YRL-150-0625-SA	0.625	1.00	2.022	2.00	1.95	2.397	2.77	0.375	1.125	0.91
YRL-200-0625-SA	0.626	1.25	2.602	2.50	2.08	2.422	2.80	0.375	1.125	1.02
YRL-200-1000-SA	1.000	1.25	2.602	2.50	2.58	3.375	3.88	0.500	1.500	1.58
YRL-250-0625-SA	0.625	1.50	3.097	3.00	2.13	2.540	2.91	0.375	1.125	1.02
YRL-325-1000-SA	1.000	1.88	3.903	3.75	2.99	3.976	4.48	0.500	1.500	1.56
YRL-400-1000-SA	1.000	2.25	4.695	4.50	2.99	3.976	4.48	0.500	1.500	1.56
YRL-500-1000-SA	1.000	2.75	5.798	5.50	2.99	4.443	4.94	0.500	1.500	1.35
YRL-600-1375-SA	1.375	3.25	6.901	6.50	3.54	5.306	5.93	0.625	2.000	1.89
*HØ -.001/-.003" AØ +.000/-.002" N+.003/+0.01"										

YATES "YS" SERIES ROUND BODY CYLINDERS

YS-2500 SERIES SUITABLE FOR AIR OR MEDIUM DUTY HYDRAULIC SERVICE.

- Ductile iron head and piston are made from fine grained centrifugally cast bar stock.
- O-ring boss ports supplied standard, NPTF available at no extra charge.
- Piston rod is ground, polished and chrome plated medium carbon steel.
- Polypak piston seals with glass-filled nylon bearing is standard.
Viton or Teflon piston seals are optional.
- Polypak rod seal with a Urethane rod wiper are standard.
High temperature rod seals are optional.
- Head gland retained with internal retaining ring is standard on medium duty.

YS-3000 SERIES FOR HEAVY DUTY USE IN HIGH PRESSURE APPLICATIONS.

- Ductile iron head and piston are made from fine grained centrifugally cast bar stock.
- O-ring boss ports supplied standard, NPTF available at no extra charge.
- Piston rod is ground, polished and chrome plated steel.
- Polypak piston seals with glass-filled nylon bearing is standard.
Viton or Teflon piston seals are optional.
- Polypak rod seal with a Urethane rod wiper are standard.
High temperature rod seals are optional.

YATES "YS" SERIES ROUND BODY CYLINDERS

CUSTOM BUILT CYLINDER APPLICATION

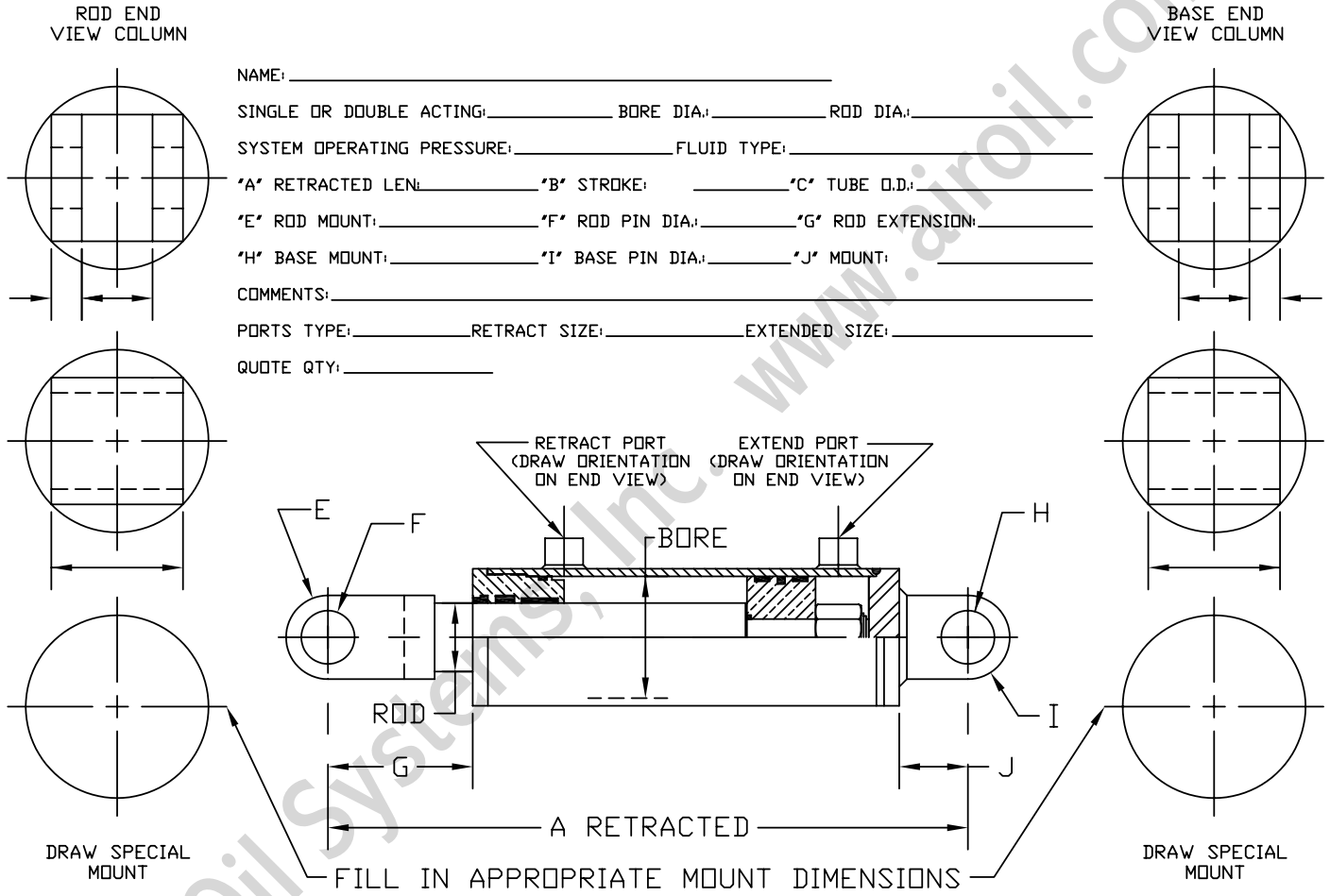

YATES INDUSTRIES YS-MIL MILL CYLINDERS

YS-MIL-A AIR SERVICE/ 200 PSI HYDRAULIC MILL CYLINDERS SPECIFICATIONS:

- 1. CYLINDER BODY**- honed to a micro finish with ends chamfered for assembly purposes. All flanges and mounting trunnions are rigidly welded to the cylinder tube. Chrome plating is available as an option.
- 2. HEAD AND CAP**- rugged construction, heads provide long male pilots for proper alignment with body.
- 3. PISTON**- one piece cast iron construction threaded on rod and positively locked. Optional bronze overlay pistons available on request.
- 4. PISTON ROD** - 100,000 psi tensile steel, turned, ground and polished with .001" hard chrome plating is standard. Heavy chrome is available as an option.
- 5. CUSHIONS** - floating rod end cushion, integral cap end spear. Needle valve and ball check provide a wide range of cushion adjustment while allowing quick break away.
- 6. IN-BOARD AND OUT-BOARD ROD BUSHINGS** - precision machined from bronze for long life. Allows easy removal of rod packing without disassembly.
- 7. PISTON SEALS** - standard u-cup design is suitable for most applications. Optional teflon glide ring and double wear bands are optional.
- 8. ROD SEALS** - v-ring packing provides leak proof operation at all pressures. Polyurethane rod wiper is standard, metallic rod scraper is available.
- 9. HEAD & CAP BOLTS** - thru bolt construction with high strength socket head screws and nuts.

YS-MIL-H HEAVY DUTY HYDRAULIC MILL CYLINDERS TO 3000 PSI SPECIFICATIONS:

- 1. CYLINDER BODY** - honed to a micro finish with ends chamfered for assembly purposes. All flanges and mounting trunnions are rigidly welded to the cylinder tube. chrome plating is available as an option.
- 2. HEAD AND CAP** - rugged construction, heads provide long male pilots for proper alignment with body.
- 3. PISTON** - one piece cast iron construction threaded on rod and positively locked. Optional bronze overlay pistons available on request.
- 4. PISTON ROD** - 100,000 psi tensile steel, turned, ground and polished with .001" hard chrome plating is standard. Heavy chrome is available as an option.
- 5. CUSHIONS** - floating rod end cushion, integral cap end spear. Needle valve and ball check provide a wide range of cushion adjustment while allowing quick break away.
- 6. IN-BOARD AND OUT-BOARD ROD BUSHINGS** - precision machined from bronze for long life. Allows easy removal of rod packing without disassembly.
- 7. PISTON SEALS** - polypak piston seal design is suitable for most applications. Optional teflon glide ring and double wear bands or cast iron rings are optional.
- 8. ROD SEALS** - v-ring packing provides leak proof operation at all pressures or polypak seals available in optional materials based on application. Polyurethane rod wiper is standard, metallic rod scraper is available.
- 9. HEAD & CAP BOLTS** - thru bolt construction with high strength socket head screws and nuts.

MILL CYLINDER HOW TO ORDER INFORMATION

Unlike the N.F.P.A. tie rod cylinders that are made to certain specification that ensures all manufacturers mounting will be interchangeable, mill cylinders have no such standard. Each manufacturer has their own dimensions and designs so care must be taken when replacing an existing cylinder. Please fill out the information on page 127 and our factory will provide a blank dimensional drawing for the particular mount that will need to be filled in with appropriate dimensions to allow us to match the original cylinder.

YATES INDUSTRIES YS-MIL MILL CYLINDERS

PLEASE CHECK THE APPROPRIATE DESIGNATIONS OR FILL IN INFORMATION WHERE REQUIRED.

Air service _____ Low pressure Hyd _____ High pressure hydraulic _____
If hydraulic indicate working pressure _____ Max rated pressure _____
Bore Diameter: _____ Stroke Length _____ Rod Diameter _____
Mounting style: _____
Rod end style: Male _____ Female _____ Other _____
Specify thread dia., pitch and length (i.e. 1 1/4-14 male x 1 5/8" long.) _____
Cushion on rod end _____ Cushion on cap end _____ Location of adjustments _____
Type of Port: NPTF _____ SAE _____ 4 bolt flange _____ Other (specify) _____
Port size rod end _____ Port size cap end _____ Location of ports _____
Operating fluid used _____ Operating temp _____
Special features required: _____

**SUPPLY ALL PERTINENT INFORMATION FROM EXISTING CYLINDER TAGS OR DESCRIPTIONS
AS WELL AS ANY DRAWINGS, SKETCHES OR PHOTOS AVAILABLE.**

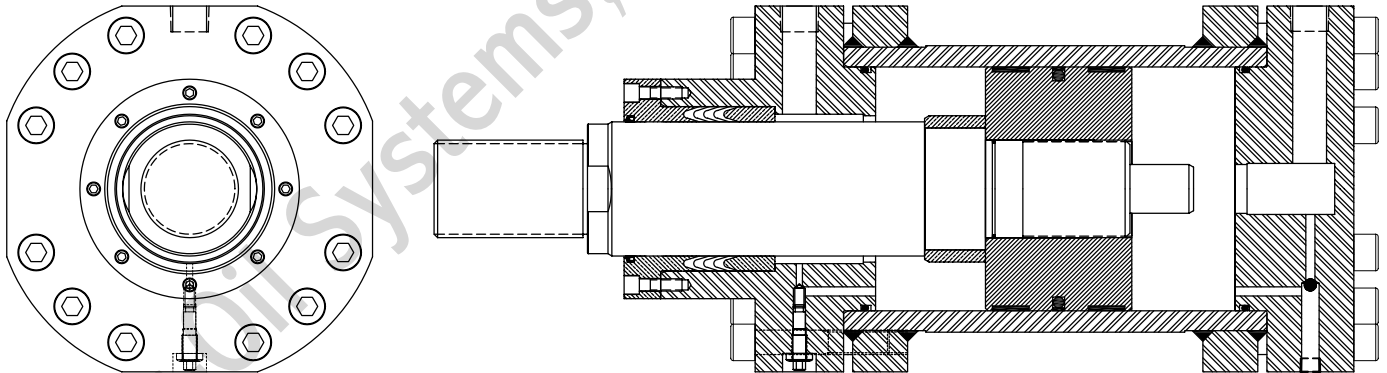



YOUR CYLINDER SOURCE

Maintenance, Service, & Installation Manual



TABLE OF CONTENTS

Introduction.....	131
Cylinder Identification	131
Installation	132
Troubleshooting	133
Replacement Parts	134
Replacement Parts Chart	135
Piston Replacement	136
Rod Cartridge Replacement	136
Barrel to Head Replacement	137

Air-Oil Systems, Inc. www.airoil.com



REPAIR INFORMATION

INTRODUCTION

This manual will help user's store, install, maintain, and if needed, repair the Yates cylinders.

CYLINDER IDENTIFICATION

Yates N.F.P.A. series cylinders can be identified by Yates serial number or Model number. Cylinders are tagged with bore, stroke, and serial number on a metal tag attached to the head. In addition, the serial number is stamped into the steel of the front head. These numbers should always be referenced when requesting parts or for general service inquiries.

STORING OF CYLINDERS

If there is a need to store the cylinders for any period of time please follow these simple instructions to help keep the cylinder in ready condition.

1. Coat the interior of the cylinder with oil and leave half filled if practical.
2. Plug all ports to ensure foreign matter is kept out of the cylinder.
3. Try to store the cylinder in a vertical position if at all possible, if not, regularly rotate the cylinder 90 degrees to ensure seals maintain proper shape and elasticity.
4. Keep all mounting surfaces and threads either covered or coated with protective lubricant.
5. Try to store components in a clean, dry area that maintains a relatively constant temperature.

**IF STORING FOR LONGER THAT ONE MONTH
ALWAYS THOROUGHLY LUBRICATE THE CYLINDER AND STROKE NUMEROUS TIMES
BEFORE INSTALLATION OR USE UNDER LOAD.**



REPAIR INFORMATION

INSTALLATION

The preferred method of mounting the cylinder to a machine is to have the equipment machined to fit the cylinders exact dimensions with proper alignment already taken into account, so that mounting the cylinder ensures perfect alignment. Unfortunately this is not always an option from a cost or design aspect so alignment must be ensured at time of installation. On fixed mount cylinders that are secured in one position, it is always best to bolt the cylinder down as the last step in installation.

When attaching the piston rod end to the load, the piston rod must be attached and held squarely to ensure the centerline is parallel to the guides of the attached load or parallel to the line of movement along the entire stroke. Torque piston rod to load. Insert mounting bolts but do not tighten.

The application operation should be cycled with low pressure air under reduced, or no load, to ensure that all components are operating freely.

Piping: All fittings should be free of burrs and sealed with either o-ring or appropriate pipe tape. Make sure all hoses are properly flushed of contaminants before attachment. Do not overtighten fittings. On oversized rods beware of shallow tapped ports.

Hydraulic filtration should be to power unit manufacturers specifications. Pneumatic systems should have a water separator, 50 micron or smaller filter, and a lubricator as close to the cylinder as possible.

REPAIR INFORMATION

TROUBLE SHOOTING

Cylinders that are properly installed and maintained should have millions of trouble free cycles. Most failures are due to application or system problems that could be prevented. Some problems, possible causes and solutions follow:

BROKEN ROD END

Cause: Misalignment or load in excess of cylinder capability.

Solution: Make sure that load is properly aligned. Select larger rod end threads or Stud rod end for greater strength.

2. BROKEN OR BENT ROD

Cause: Misalignment or load in excess of cylinder capability.

Solution: Make sure that rod is aligned properly through entire stroke.
Consult Yates sales representative to select proper rod size for application.

3. SEAL DAMAGE

Cause: Improper seal selection or system contamination.

Solution: Consult Yates sales engineer for proper seal for temperature or fluid media.
Use proper filtration from system manufacturers spec.

4. EXCESSIVE PISTON ROD WEAR

Cause: Side load or long stroke and improper stop tube selection.

Solution: Check alignment of rod and load along entire stroke.
Consult Yates catalog for proper stop tube configuration.

5. BROKEN PARTS

Cause: Exceeding cylinder pressure rating. Need for system speed controls, cylinder cushions or if present improperly adjusted.

Solution: Lower system pressure to minimum required to accommodate application.
Adjust speed controls or cushions to lower shock.

REPAIR INFORMATION

REPLACEMENT PARTS

If needed, any cylinder component can be replaced. When contacting a Yates sales representative please have the following information: model number, bore, stroke, or Yates serial number (as found on the metal tag attached to the cylinder or stamped into the front head) and part description from diagram on page 135.

If repair becomes necessary due to seal leakage, a complete rebuild set should be obtained. This set includes pistons seals, barrel to head seals, rod seals and bronze rod gland. For seal replacement instruction refer to pages 136 & 137. (For seal orientation refer to diagram on page 135.)



REPAIR INFORMATION

REPLACEMENT PARTS

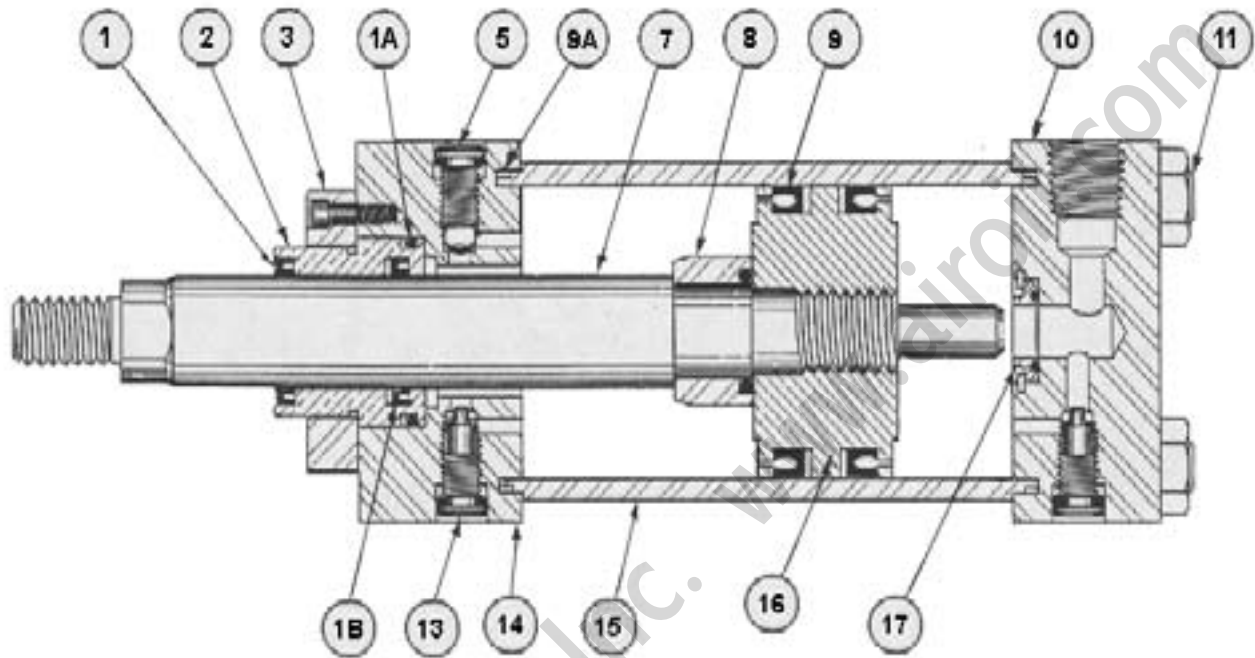

REPLACEMENT PARTS			
ITEM	DESCRIPTION	ITEM	DESCRIPTION
1, 1A, & 1B	ROD SEAL KIT **	10	REAR CAP
1, 1A, 1B, & 2	ROD GLAND KIT **	11	TIE RODS AND NUTS
3	RETAINER RING/PLATE	13	CUSHION NEEDLE ASSEMBLY
5	BALL CHECK ASSEMBLY	14	FRONT HEAD
7	PISTON ROD	15	CYLINDER TUBE
8	CUSHION SPUD W/ SEAL	16	PISTON
9 & 9A	PISTON SEAL KIT	17	CUSHION STAR ASSEMBLY

**WHEN ORDERING REPLACEMENT PARTS,
SPECIFY SERIAL NUMBER, MODEL NUMBER, BORE, STROKE, AND PISTON ROD DIAMETER.**

REPAIR INFORMATION

PISTON REPLACEMENT

1. To remove loctited piston from rod, heat piston and rod to 450 degrees.
 2. Using a spanner wrench, remove piston (while hot) by turning counter clockwise.
 3. Allow piston & rod to air cool before cleaning and reassembling.
 4. Clean threads of piston and rod with Loctite cleaner and degreaser. Spray threads with Loctite #7649 primer and allow to air dry (DO NOT BLOW DRY).
 5. Screw piston to rod making sure of a good fit, then back the piston off about 3/4 of the way.
 6. Apply (high strength) grade 680 loctite to rod thread and into piston thread on top of rod. Screw the piston clockwise all the way down.
 7. Use spanner wrench to torque down piston.
 8. Prick punch rod with center punch (2 places) so rod thread protrudes into piston thread. Clean any loose material and loctite.
 9. Install new seals on piston, lubricate with grease or equivalent.
 10. Install piston into tube without damaging
- NOTE:** Allow loctite to cure for 3 hours before applying test pressure to assembled cylinder.

ROD CARTRIDGE REPLACEMENT

1. There will be a circular retainer or a square retainer at the rod end. If there is a circular retainer, remove the socket head cap screws. If it is a square retainer remove the tie rod nuts.
2. Remove the circular retainer as show in Fig. 2
3. Remove the rod cartridge, by inserting a screwdriver in the external groove. Pry carefully. See Fig. 3
4. Clean cartridge recess in the head
5. Lubricate new rod cartridge and seals with grease of equivalent, inside and out before assembly.
6. (Caution) Place new cartridge on the rod end being sure to use a "screwing motion"
7. Insert cartridge (now mounted on rod) into head recess.
8. Replace circular retainer plate, tie rod nuts or socket head cap screws, and tighten to original torque specs. See Fig.1 for Torque Specs. or see Fig 4 for tie rod nut tightening pattern.

RETAINER RING	
SCREW	TORQUE
SIZE	FT/LBS.
1/4-20	15
5/16-18	32
3/8-16	60

FIG. 1



FIG. 2



FIG. 3

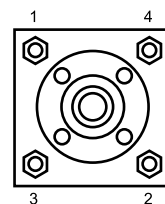

FIG. 4

REPAIR INFORMATION

1. Remove tie rod nuts and washers.
2. Remove head and cap from cylinder
3. Discard old seals and clean all parts, including inside tube, grooves in head and cap.
4. For all A2 series cylinders install o-ring seal in bottom of groove in head and cap.
5. When installing PTFE continuous ring type seals for series A4, H4, and H6 (1 1/2" through 6" Bore) avoid stretching seals.
6. For A4 and H4 series (8" Bore and up) insert seals in bottom of groove in the head and cap.
7. When installing PTFE noncontinuous ring type seal for series H6 (7" Bore and up) insert seal in carefully to avoid stretching. (See Fig. 1 and Fig. 2)
8. Assemble cylinder and tighten tie rod nuts hand tight.
9. Torque Tie Rod Nuts in order shown in Fig. 3 (using chart below for Torque specifications)



FIG. 1

Be sure to butt ends of seal together as you begin to seat seal in groove



FIG. 2

Hold the ends together and in place with one finger while seating the rest of the seal with your other hand.

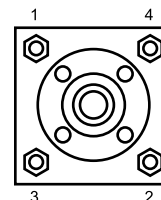

FIG. 3

SERIES H6			SERIES A4			SERIES A2		
BORE	TIE ROD DIA. (IN.)	TORQUE (FT./LB.)	BORE	TIE ROD DIA. (IN.)	TORQUE (FT./LB.)	BORE	TIE ROD DIA. (IN.)	TORQUE (FT./LB.)
1 1/2	3/8	27 ±2	1 1/2	1/4	10 ±2	1 1/2	1/4	8 ±2
2	1/2	33 ±3	2	5/16	16 ±2	2	5/16	12 ±2
2.5	1/2	65 ±5	2.5	5/16	16 ±2	2.5	5/16	12 ±2
3.25	5/8	155 ±10	3.25	3/8	26 ±3	3.25	3/8	19 ±2
4	5/8	180 ±10	4	3/8	26 ±3	4	3/8	19 ±2
5	7/8	435 ±20	5	1/2	65 ±5	5	1/2	45 ±4
6	1	545 ±20	6	1/2	65 ±5	6	1/2	45 ±4
7	1 1/8	755 ±30	8	5/8	155 ±10	8	5/8	115 ±6
8	1 1/4	980 ±40	10	3/4	235 ±10			
10	1 1/8	750 ±30	12	3/4	235 ±10			
12	1 1/4	980 ±40	14	7/8	435 ±20			
14	1 1/4	980 ±40	16	1	545 ±20			
16	1 1/2	1400 ±50	18	1.125	745 ±30			
18	1 1/2	1400 ±50	20	1.25	980 ±40			
20	1 1/2	1400 ±50						

TERMS AND CONDITIONS

ACCEPTANCE

This quotation together with any other documents herein or attached hereto, constitutes an offer by Yates Industries, Inc. hereafter termed Seller, to supply Buyer the Goods to be purchased pursuant to this quotation. This quotation supersedes any prior oral or written communications between Seller and Buyer. BY ACCEPTING THE GOODS, ORDERING THE GOODS, OR ACKNOWLEDGING RECEIPT OF THIS QUOTATION, BUYER AGREES TO AND ACCEPTS THE TERMS AND CONDITIONS, CONTAINED HEREIN. ANY ADDITIONAL OR DIFFERENT TERMS OR CONDITIONS, INCLUDING THOSE CONTAINED IN BUYER'S PURCHASE ORDER OR ACCEPTANCE OF THIS OFFER ARE HEREBY OBJECTED TO. If any terms or conditions in the purchase order or acceptance of this offer are in conflict or not identical to the terms of this offer, the terms and conditions of this offer shall prevail. This offer may be withdrawn by Seller at any time prior to Buyer's acceptance of the terms and conditions contained herein, and will expire automatically 30 days from the date hereof unless accepted by Buyer.

PRICES - Prices quoted by Seller in this quotation are:

1. Subject to change without notice prior to acceptance of Buyer's order by Seller.
2. Exclusive of all Federal, State, Municipal or other Government Excise Sales Use, Occupational or like taxes now in force or to be enacted in the future.
3. Subject to an increase equal in amount to any tax Seller may be required to collect to pay upon the sale of the items quoted.
4. Quoted FOB, place of manufacture.

TERMS

1. Interest may be charged at the rate of one and one-half percent per month or the maximum rate allowed under state law, if it is a lesser number, on any payments which are not received by the due date. Any expenses of collection, including reasonable attorney's fees, shall be borne by Buyer.
2. Seller reserves the right to modify these terms for export business and special projects.

SHIPPING ESTIMATES

1. The shipping date shown in this quotation is approximate and dependent upon prior sales and circumstances beyond Seller's control.
2. The Shipping date will be computed from the date of receipt of all data required to enable complete engineering or acceptance of Buyer's order as provided in the Acceptance paragraph above, whichever is later.
3. Seller shall not be liable for delays, stoppages, or defaults in shipments directly or indirectly due to causes beyond its control, or caused by Act of God, fire, strikes, flood, embargo, epidemic, quarantine restrictions, war, insurrection or riot, acts of civil or military authorities, acts of government, delays in transportation of fabrication, priorities of Seller, unusually severe weather, inability to obtain materials, or defaults of suppliers or subcontractors. In the event of any such delay, the date of shipment shall be extended for a reasonable length of time and the period of such extension shall not be less than the period of delay. If at any time Seller has reason to believe that delivery will not be made as scheduled, it will notify Buyer in writing of the causes of the anticipated delay. Buyer's receipt of the Goods, upon their delivery, waives all of Buyer's claims for delay. Buyer's damages under this section are limited to the terms of the Limitation of Liability section of this quotation.
4. IN NO EVENT SHALL SELLER BE LIABLE FOR ANY INCIDENTAL OR CONSEQUENTIAL DAMAGES OCCASIONED BY DELAYS WHETHER OR NOT SUCH DELAYS ARE BEYOND SELLER'S CONTROL.

DELIVERY

All Goods shall be shipped FOB, Seller's plant. Seller shall have the right to select the carrier unless the carrier is designated by Buyer and upon delivery of the Goods by Seller to the carrier, the carrier shall be deemed to be the agent of Buyer and thereafter risk of loss shall be on Buyer.

INSTALLATION

All costs incidental to the erection and installation of the Goods shall be borne by Buyer. Additional or special services will be quoted on request.

PRODUCTION ESTIMATES

1. Production estimates, if made a part of this quotation, are based on Seller's analysis and understanding of the work to be performed and assume various production factors including normal working conditions, competent operators, proper maintenance of the Goods, and the use of materials which conform to: (i) the specifications contained herein, (ii) the specifications attached to the Goods and (iii) the standards of the industry. It is therefore EXPRESSLY UNDERSTOOD THAT PRODUCTION ESTIMATES ARE NOT GUARANTEED.
2. Work tolerances, if any, to be obtained by the Goods are based on Seller's

assumption that the material to be processed will have been properly processed through all previous operations and the locating surfaces will be of a quality which will not impede achievement of the quoted tolerances.

3. Seller's obligation with respect to production estimates shall be fully and completely satisfied when Buyer has approved and acknowledged that the Goods have been operated at the estimated performance level for a period acceptable to Buyer but in no event for more than (1) one hour. Such operation of the Goods shall be performed at the place of final assembly of the Goods by or at the direction of Seller.

LIMITED WARRANTY

1. Seller warrants that the Goods to be delivered will be of the kind and quality described in this quotation and will be free of defects in workmanship or material. Should any of the Goods covered by this quotation which, under normal operating conditions in the plant of Buyer, prove defective in material or workmanship within (3) three years (six (6) months in the case of reconditioned or repaired cylinders) from the date of shipment by Seller, as determined by inspection by Seller, Seller will repair or replace it free of charge, provided that Buyer promptly notifies Seller of the defect and establishes that the Goods have been properly installed and maintained and operated on a single work shift basis, within the limits of rated and normal usage. Seller will not accept any charge for removal, installation, assembly, or any other charges in connection with replacement or repair of the cylinder. All cylinders under warranty which are alleged to be defective are to be returned to Seller, freight prepaid. A complete explanation is required of the alleged defects and circumstances of such claimed failure. Yates Industries will provide an RMA# (return material authorization) that must accompany the item being returned.
2. The terms of this limited warranty apply only to equipment manufactured by Seller and do not apply to components, parts or accessories purchased by Seller including but not limited to pumps, gear reducers, electrical controls, motors and other purchased items. These items will carry only the warranty issued by the original manufacturer, and Seller is not responsible for any warranty claims beyond that covered by the original equipment manufacturer.
3. This limited warranty shall be void and Seller shall not be liable for any breach of warranty if the Goods or parts covered by this quotation shall have been repaired or altered by persons other than Seller unless expressly authorized in writing by Seller or if the Goods are operated or installed contrary to Seller's instructions or subjected to misuse, negligence or accident.
4. THE FOREGOING WARRANTY IS EXCLUSIVE AND IS IN LIEU OF ALL OTHER WARRANTIES EXPRESSED OR IMPLIED. ALL IMPLIED WARRANTIES OF MERCHANTABILITY AND FITNESS FOR A PARTICULAR PURPOSE ARE HEREBY DISCLAIMED BY SELLER AND ARE EXCLUDED FROM THIS AGREEMENT. THERE ARE NO WARRANTIES WHICH EXTEND BEYOND THE DESCRIPTION ON THE FACE HEREOF. No agent, employee or representative of Seller other than an officer duly authorized in writing has any authority to bind Seller to any confirmation, representation or warranty concerning the Goods that are covered by this quotation beyond that specifically included in this quotation.
5. The cost of all non-warranty service will be charged by Seller at a per diem rate, per man, per work day, plus transportation and living expenses.

LIMITATION OF LIABILITY

1. BUYER'S EXCLUSIVE REMEDY FOR BREACH OF WARRANTY SHALL BE REPAIR OR REPLACEMENT OF DEFECTIVE GOODS as provided in the limited warranty stated herein. This EXCLUSIVE REMEDY shall not be deemed to have failed of its essential purpose so long as Seller is willing and able to repair or replace defective parts in the prescribed manner. However, if the Goods are incapable of being repaired or replaced, Buyer's exclusive remedy shall be money damages, but such damages shall not exceed the purchase price of the defective Goods. Seller recommends that Buyer purchase mechanical break-down insurance as an additional protection to the limited warranty.
2. Any claim for breach of Seller's limited warranty must be in writing, addressed to Seller and must set forth the alleged defect in sufficient detail to permit its easy identification by Seller. Buyer's failure to notify Seller as set forth above will be conclusively deemed Buyer's waiver of its claim.
3. Seller's liability on any claim of any kind, including negligence, for any loss or damage arising out of, connected with, or resulting from this quotation or from the performance or breach thereof, or from the design, manufacture, sale, delivery, resale, installation, technical direction of installation, inspection, repair, operation or use of any Goods covered by or furnished under this quotation shall in no case (except as provided in the paragraph entitled Property and Patent Rights), exceed the purchase price allocable to the Goods and shall terminate one year after the Goods have been shipped.
4. IN NO EVENT, WHETHER AS A RESULT OF BREACH OF CONTRACT OR WARRANTY OR ALLEGED NEGLIGENCE OR OTHERWISE, SHALL SELLER

TERMS AND CONDITIONS (CONT.)

BE LIABLE FOR SPECIAL, INCIDENTAL, INDIRECT OR CONSEQUENTIAL DAMAGES, INCLUDING, BUT NOT LIMITED TO, ANY LOSS OF PROFIT, LOSS BY REASON OF PLANT SHUTDOWN, INCREASED EXPENSE OF OPERATION, LOSS OF PRODUCT OR MATERIALS, LOSS OF USE OF THE GOODS OR ANY ASSOCIATED EQUIPMENT, COST OF CAPITAL, COST OF SUBSTITUTE EQUIPMENT, FACILITIES OR SERVICES, DOWNTIME COSTS OR CLAIMS OF CUSTOMERS OF BUYER FOR SUCH DAMAGES OR ANYTHING DONE IN CONNECTION WITH THIS QUOTATION (INCLUDING ANY MAINTENANCE OR INSTALLATION SERVICES) OR ANY OTHER LOSSES RESULTING FROM THE OPERATION OR NON-OPERATION OF THE GOODS WHETHER BASED UPON CONTRACT, TORT (INCLUDING NEGLIGENCE), STRICT LIABILITY OR OTHERWISE EVEN THOUGH SELLER MAY HAVE BEEN ADVISED OF THE POSSIBILITY OF SUCH DAMAGES. IN ANY EVENT, SELLER'S LIABILITY WITH RESPECT TO THE GOODS SHALL NOT EXCEED AN AMOUNT EQUAL TO THE PURCHASE PRICE THEREOF.

5. If Buyer or Buyer's customers re-label, re-package, alter, or modify the Goods, then Seller shall be released from all obligations and liabilities to Buyer and Buyer shall defend, indemnify and hold Seller harmless from and against all claims, costs and liabilities arising out of or related to any product defect, including any resulting personal injury, property damage, and consequential damages.

PRODUCT LIABILITY AND INDEMNIFICATION

1. Buyer shall use and shall require its employees to use all safety devices, guards and safe and proper operating procedures as set forth in the nameplates, signs, manuals and instruction sheets relating to the Goods furnished by Seller. Buyer shall not remove or modify any such device or guard or warning sign. Buyer shall not permit non-operating personnel to remain within ten (10) feet of any machine or accessory that is purchased pursuant to this quotation, while such machine or accessory is in operation. If Buyer fails to strictly observe each and every one of the obligations set forth in this paragraph with regard to any machine or accessory purchased pursuant to this quotation, Buyer agrees to defend, indemnify and hold Seller harmless from any liability or obligation incurred by Seller to persons injured directly or indirectly in connection with the operation of any such machine or accessory.
2. Buyer shall notify Seller promptly and in any event within thirty (30) days of any accident or malfunction involving any of the Goods which results in personal injury or damage to property and shall cooperate fully with Seller in investigating and determining the cause of such accident or malfunction. In the event that Buyer fails to give such notice to Seller and so cooperate, Buyer agrees to defend, indemnify and hold Seller harmless from any claims arising from such accident or malfunction.

PROPERTY AND PATENT RIGHTS

1. Seller retains for itself any and all property rights in and to all designs, inventions and improvements pertaining to any Goods designed in connection with the quotation and to all patents, trademarks, copyrights and related industrial property rights arising out of the work done in connection therewith. Buyer expressly agrees that it will not assert any rights to property rights retained herein by Seller.
2. Seller will indemnify and hold harmless Buyer from any and all costs, expenses and damages resulting from any suit based on any claim of infringement of a United States patent by reason of its use (in the manner contemplated by Seller) of the Goods, or any part thereof, furnished under this quotation, provided that Buyer: (i) promptly notifies in writing Seller of any such claim or the institution of any such suit; (ii) fully cooperates with Seller in connection with the defense thereof; and (iii) allows, without condition, Seller to have the full and exclusive right to defend any such suit to the extent any of the Goods furnished under the quotation is involved therein. In the event of any such claim or suit, Seller shall have the right to modify or replace the Goods involved in any claim of infringement or to remove such Goods and refund to Buyer the purchase price thereof less fifteen (15) percent to each full year from the date of shipment of the Goods. NOTWITHSTANDING THE FOREGOING, SELLER'S CUMULATIVE LIABILITY FOR INDEMNIFICATION UNDER THIS PARAGRAPH SHALL NOT EXCEED THE PURCHASE PRICE FOR THE GOODS INVOLVED IN ANY SUCH CLAIM OF INFRINGEMENT. This Paragraph shall not apply to (i) any foreign patents; (ii) any process in which the Goods are used; (iii) any product made by Buyer; or (iv) any claims or suits involving solely goods not manufactured or designed by Seller harmless from any liability arising out of any infringement of any patent in the manufacture, sale or use of any goods or parts thereof manufactured by Seller to Buyer's design specifications.

RESERVATION OF RIGHTS IN RESPECT TO SELLER'S OTHER PRODUCTS

Seller reserves the right to make improvements and changes in design of the Goods it offers for sale without any obligation to make such changes or improvements upon the Goods that are the subject of this quotation or Goods previously manufactured and sold by it.

CHANGES

Buyer accepts the limited capabilities of the Goods, their materials and components upon approving the design of the Goods. Buyer shall bear the cost of all subsequent changes to the design, materials and/or components of the Goods subsequent to approving the design. Buyer shall request all such changes by change order, and pay the cost of the change, in full, within 30 days of submitting the change order.

LIMITATION OF ACTIONS

Any statute or law to the contrary notwithstanding, any action to recover for any loss or damage arising out of, connected with, or resulting from this quotation, or from the performance or breach thereof must be commenced within one year after the cause of action accrues to Buyer, unless otherwise extended by Seller in writing. It is expressly agreed that there are no warranties of future performance pertaining to the Goods that are the subject of this quotation that would extend beyond such one year period of limitation.

CANCELLATION

1. In the event Buyer requests Seller to stop work or cancel its purchase order based on this quotation, the order or any part thereof, cancellation charges shall be paid to Seller as follows: Any and all work that is complete or scheduled for completion within thirty (30) days of the date of notification in writing to stop work or to cancel, shall be invoiced and paid in full.
2. For work in process, other than covered by item 1, and any materials and supplies procured or for which definite commitments have been made by Seller in connection with Buyer's order, Buyer shall pay the actual costs and overhead expenses determined in accordance with good accounting practices, plus 15 percent.
3. An amount equal to 15 percent of the difference between the cancellation charge as computed in item 2 and the full purchase price of the Goods will be charged as compensation for business irretrievably lost as a result of accepting a purchase order based on this quotation and having such purchase order cancelled by Buyer.
4. Buyer shall promptly instruct Seller as to the disposition of the Goods and the latter shall, if requested, hold the Goods for Buyer's account. All costs of storage, insurance, handling, boxing or other costs in connection therewith shall be borne by Buyer.

APPLICABLE LAW

This quotation and the rights, obligations and liabilities of the parties, shall be construed pursuant to the laws of the State of Michigan.

COMPLETE AGREEMENT

1. Any orders received by Seller in response to this quotation shall not be binding or firm orders until approved by Seller. This quotation, when accepted by Buyer in accordance with the Acceptance paragraph hereof, and when Seller's acknowledgement of receipt of acceptance is given to Buyer, shall constitute the entire agreement between the parties relating to this quotation and the Goods provided pursuant thereto, shall supersede all previous communications or understandings between Buyer and Seller with respect to the subject matter hereof and no alteration or addition to this quotation shall be binding on Seller unless it is in writing and signed by a duly authorized officer of Seller.
2. The parties hereto agree that if any clause is held unenforceable by a court of competent jurisdiction, the balance of the contract shall remain in full force and effect.

WAIVER OF TERMS AND CONDITIONS

Failure or delay of Seller to insist upon strict performance of any of the terms and conditions of this quotation or to exercise any rights or remedies provided herein or by law, shall not release Buyer from any of the obligations of this quotation and shall not be deemed a waiver of any right of Seller to insist upon strict performance hereof or of any rights or remedy of Seller as to any prior or subsequent default hereunder.





YATES
Cylinders

LADLE LIFT CYLINDER – CONTINUOUS CASTER



14" bore x 56" stroke
10" diameter rod
3000 psi rated



MAIN FRAME CYLINDER – CONTINUOUS CASTER

17" bore x 230mm stroke
8" diameter rod
3100 psi rated



COUNTER BALANCE CYLINDER – STAMPING PRESS

500mm bore x 710mm stroke
100mm rod diameter
250 psi air service



STAINLESS STEEL PHARMACEUTICAL DRUG PRESS

4" bore x 24" stroke
1 3/4" diameter rod
2500 psi rated
Mirror-polished stainless steel



CLOSING CYLINDER – DREDGE BARGE

21" bore x 137" stroke
10" diameter rod
6000 psi rated



SIMULATOR CYLINDER – EARTHQUAKE SIMULATOR

424mm bore x 1060mm stroke
200mm double rod
3000 psi rated





24 HOUR EMERGENCY SERVICE

- H6 – Heavy Duty Hydraulic Cylinders
- A4, L4, H4 – Heavy Duty Air or Medium Duty Hydraulic cylinders
- A2/H2 – Aluminum Air or Hydraulic Service Cylinders
- YS-MIL – Air and hydraulic mill type cylinders
- YS Series Round Body Cylinders
- Special cylinders per customer's print & specifications
- Cylinders with Proximity, Reed, or Hall effect switches
- Cylinders with Linear Displacement Transducers
- Air/Oil Intensifiers
- Tandem, Duplex, & Back to Back cylinders
- Stainless Steel Cylinders and cylinders with special plating or painting
- Accessories: rod clevises, rod couplers, eye brackets, rod boots, etc.



YATES INDUSTRIES IS A MEMBER OF
THE NATIONAL FLUID POWER ASSOCIATION

23050 Industrial Dr. E.
St. Clair Shores, MI 48080
(586) 778-7680 **ph**
(586) 778-6565 **fax**
www.yatesind.com
sales@yatesind.com