

# PNEUMATIC CYLINDERS

## HEAVY DUTY PNEUMATIC CYLINDERS



STANDARD BRASS AND  
STEEL CONSTRUCTION

ALL-STAINLESS STEEL  
CONSTRUCTION

NFPA TIE-ROD DESIGN

CUSTOM DESIGNS

ALSO:

VALVE ACTUATORS

SPRING EXTEND AND RETRACT

POSITION SENSING CYLINDERS

BOOSTERS

LINEAR AIR MOTORS

FEATURING THE EXCLUSIVE  
**MIRACALUBE®**  
SELF-LUBRICATING SYSTEM

**LEHIGH®**  
FLUID POWER, INC.

[www.lehighfluidpower.com](http://www.lehighfluidpower.com)



## **FLUID POWER . . .**

### ***Pneumatic and Hydraulic Power!***

You are sure to note some special features on our industrial pneumatic and hydraulic cylinders. Like our exclusive Miracalube® lubricant on our air cylinders. And our unique ability to mount tie-rod limit switches on hydraulic cylinders. And then there's our line of stainless steel cylinders.

#### **Industrial Pneumatic and Hydraulic Cylinders**

We have been manufacturing cylinders since the 1940's. Our standard materials include brass tubing for our air and medium duty hydraulics, steel for high pressure, and stainless steel for any application. With our capabilities your engineering application gets focused and expert attention, and your purchasing gets competitive pricing.

We welcome the one-of-a-kind special as well as the OEM quantity. So whether your requirements are frequent or few, standard or custom, we are here to help.

#### **Better By Design**

Among our innovations: The Miracalube® self-lubricated air cylinder. Its lubricant is made of FDA approved materials and does not mist into the atmosphere. Over 50 million linear feet of piston travel have been reported in case histories!

Among our features: Limit switches can be tie-rod mounted on our medium duty hydraulic cylinders! This is unique in the industry, allowing sensing to be set anywhere along the stroke without external mechanisms.

And... These cylinders are offered from the catalog in bore sizes from 3/4" to 20" in pressures up to 250 PSI in air and up to 3,000 PSI hydraulic, with custom design for specials!

The information in this catalog should be used as a guide for your consideration, investigation and verification. This information does not constitute a warranty or representation and we assume no legal responsibility or obligation with respect thereto, and the use to which such information may be put.

As product improvement is a continuous process, specifications are subject to change without notice.

## SOME OF OUR CUSTOM DESIGNS

*Specials are welcome!*

We have a long history of producing custom design cylinders that are specific to a customer's application. This includes such special features as:

Unique mounting requirements  
Composite materials  
High-temperature cylinders  
Alternate media cylinders  
Larger bore cylinders  
Position sensing cylinders  
Engineered spring extend or retract cylinders

Non-rotating rods  
Tandem force cylinders  
Underwater operation  
Higher pressure cylinders  
Locking cylinders

12" Bore x 2" Stroke  
9" Dia. Piston w/8" Bore Thru  
with (4) 1" Dia. Ejector Rods



20" Bore Pneumatic Cylinder  
Tandem Force Multiplier



14" Bore Air Cylinder  
Double Rod End  
with Manual Override, Extend & Retract

1" x 6" Electro-Hydraulic  
Transducer Cylinder



2" Bore Air Cylinder  
Extended Double Rods, Special Nose Mount



6" Bore Stainless Steel  
2,500 PSI Hydraulic Cylinder  
with Linear Transducer & Cover

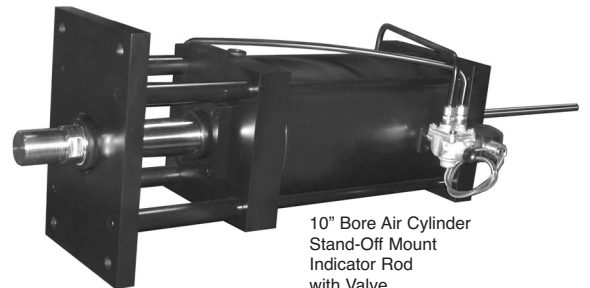
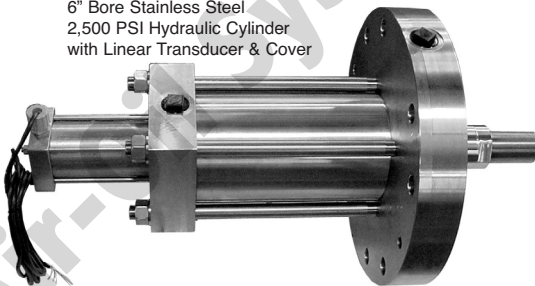

10" Bore Air Cylinder  
Stand-Off Mount  
Indicator Rod  
with Valve

10" Bore Air Cylinder  
with Air Valve, Manual Rod  
Lock, and Limit Switches

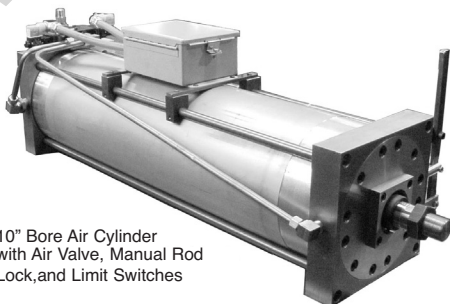

Air & Hydraulic Cylinder  
Rod-within-Rod



## SERIES JHD HEAVY DUTY AIR CYLINDER

*The Lehigh Miracalube® Air Cylinder  
The Only Real Self-Lube Air Cylinder in the World*

### **BENEFITS!**

The true test of a cylinder is how well it performs in your application. This has been our philosophy since 1948 when we first designed and manufactured the exclusive Miracalube® self-lubricated air cylinder system. This combination of innovative design features plus the finest available materials and workmanship has earned us an industry-wide reputation of excellence.



The unique Miracalube® internal reservoir system meters a specially formulated non-toxic, ingestible, low-vapor pressure lubricant - totally solvent-free for millions of trouble free cycles. Unlike contaminating airline lubricants, Miracalube® will not mist or atomize and, being solvent-free, will not dissolve seals or fuse lipseals to the tube ID if the piston remains in one position for any extended time. This means that you can run our cylinder without the usual inline lubricator, and that means no spray from the exhaust!

Other standard Lehigh high-performance features include a tough, no-rust/non-pitting hard-tempered brass cylinder tube for extended piston seal life and a long self-lubed, readily removable sintered bronze rod bearing with grooved design for doubled oil capacity.

Our Series JHD air cylinders offers bore sizes from 3/4" to 20", maximum pressures up to 250 PSI, and strokes to over 10 feet. We design to match our customers' cylinder and seal requirements, whatever they may be.

You'll benefit with the Miracalube® air cylinder's longer life, less downtime, no air line lubrication, and smooth, low breakaway startups for increased productivity. Let Lehigh's sales and engineering departments help you select the best product for your application needs.



**The Series JHD Heavy Duty Air Cylinder**  
**The Miracalube® Series . . . Real Self-Lubrication**

**FEATURES!**

**The Series JHD Heavy Duty Air Cylinder Comes Standard with the Following Design Features:**

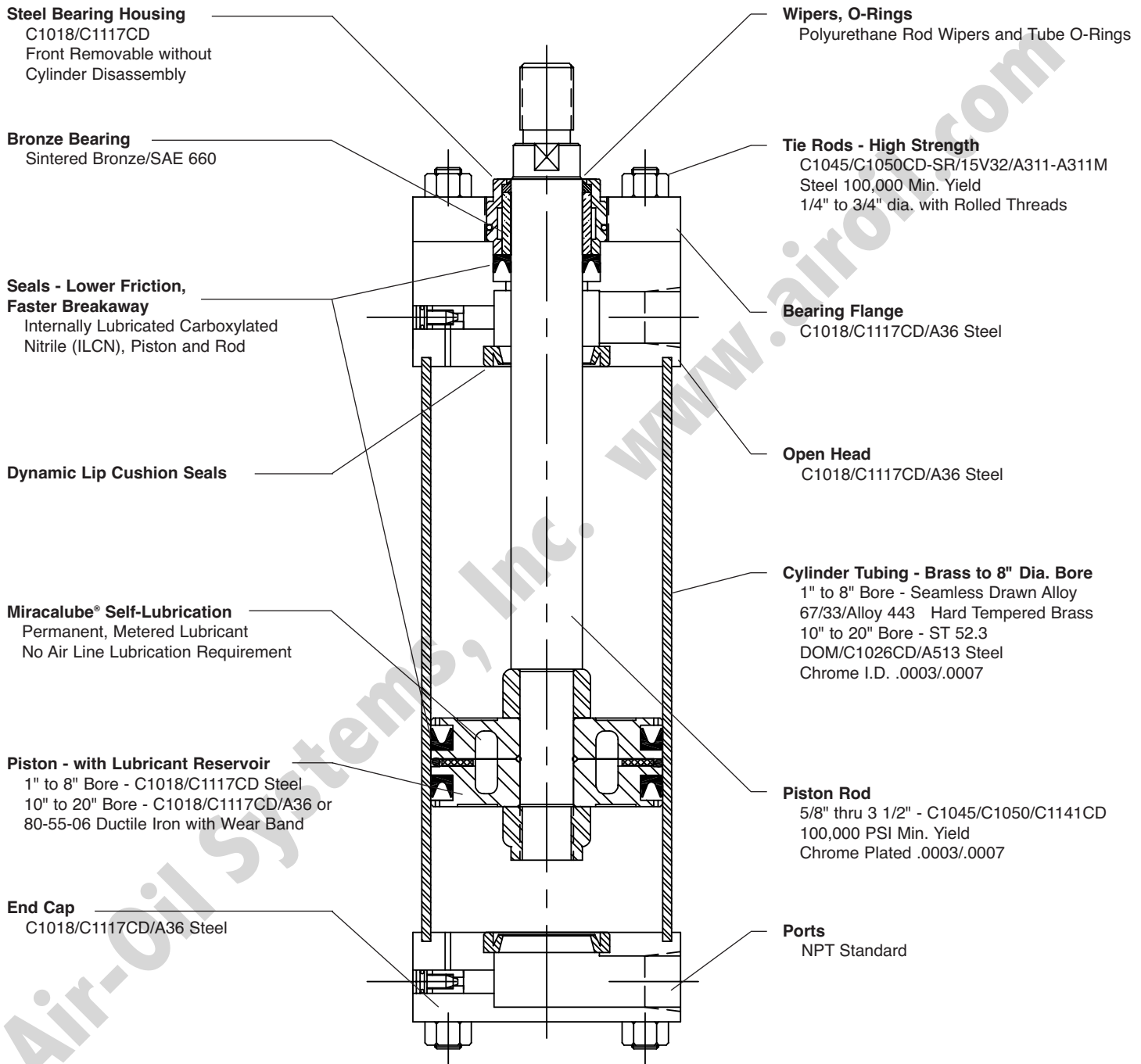

Other ... Pneumatic Service to 250 PSI ... Operating Temp. from 0° to 165° F (Standard), to 400°F (Optional Seals)

**Custom Pneumatic Cylinders**

An important part of our business is the custom cylinder design. The Series JHD pneumatic cylinder is available in virtually any configuration required by your special application. When you contact us with your design challenges, chances are that our engineering will meet the requirements of your special mounting, material, seal, temperature, sensing or other needs.



## SERIES LSSL STAINLESS STEEL AIR CYLINDER

*The Lehigh Stainless Steel Air Cylinder  
Real Self-Lube with Miracalube®*

### **BENEFITS!**

Look inside our new Series LSSL pneumatic stainless steel cylinder and you will see that we build more quality and features in ... to get more productivity out.



The benefits of improved corrosion resistance coupled with the integrity of stainless steel, plus the exclusive Lehigh Miracalube® mist-free oil self-lubrication system, make the Lehigh Series LSSL a truly unique cylinder for standard or special applications.

Lehigh stainless cylinders use broached stainless steel blocks and precision bored and honed stainless tubing. Chrome plated stainless steel rods are used to improve resistance to scratches and dents. The Miracalube® self-lubrication system eliminates the need for in-line lubrication and does not mist in the atmosphere.

Our Series LSSL air cylinders are available in bore sizes from 3/4" to 20", maximum pressures up to 250 PSI, and strokes to over 10 feet. We design to match our customers' cylinder and seal requirements, whatever they may be.

Applications include, among others: pharmaceutical and medical clean room equipment; food industry products that require USDA approvals; chemical industry equipment; wet applications (marine, dock, underwater, sewage, water treatment); and gate or other type valves.

The best feature of a Lehigh stainless steel cylinder is the long term savings in both reduced downtime and maintenance. Let Lehigh's sales and engineering departments help you select the best product for your application needs.

# The Series LSSL Stainless Steel Air Cylinder Built to Survive Where Other Cylinders Fail

## FEATURES!

The Series LSSL Stainless Steel Air Cylinder Comes Standard with the Following Design Features:

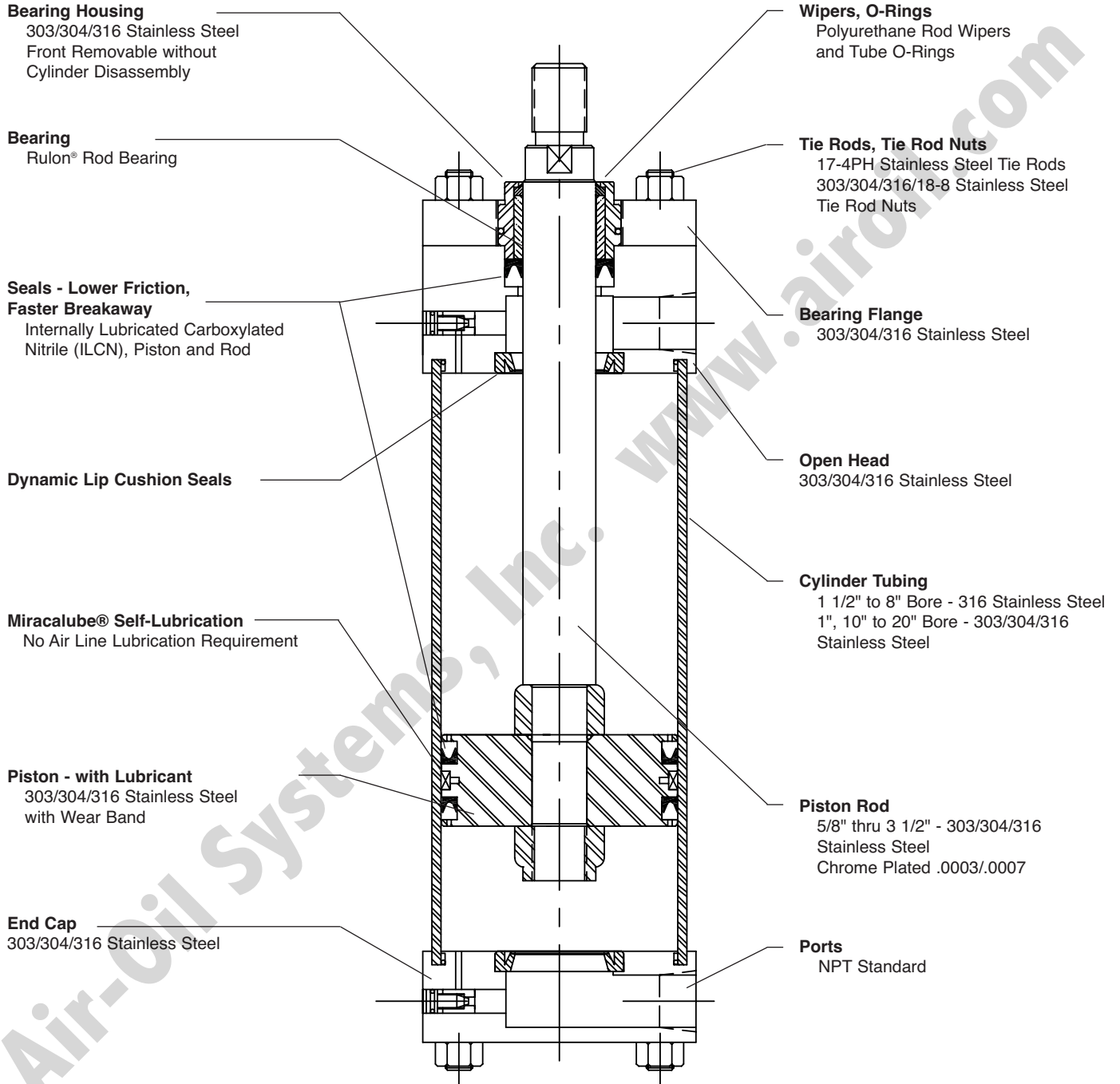

Other ... Pneumatic Service to 250 PSI ... Operating Temp. from 0° to 165° F (Standard), to 400°F (Optional Seals)

### Custom Stainless Steel Pneumatic Cylinders

An important part of our business is the custom cylinder design. The Series LSSL stainless steel pneumatic cylinder is available in virtually any configuration required by your special application. When you contact us with your design challenges, chances are that our engineering will meet the requirements of your special mounting, material, seal, temperature, sensing or other needs.

# MOUNTING STYLES

## TIE ROD and NOSE MOUNT Cylinders

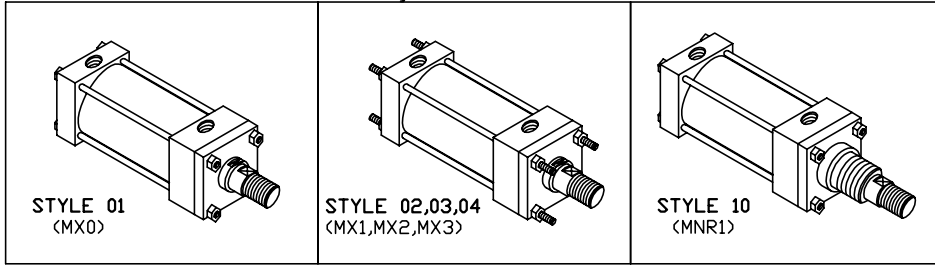

Lehigh Style No.  
(NFPA Standard No.)

## FOOT and FLUSH MOUNT Cylinders

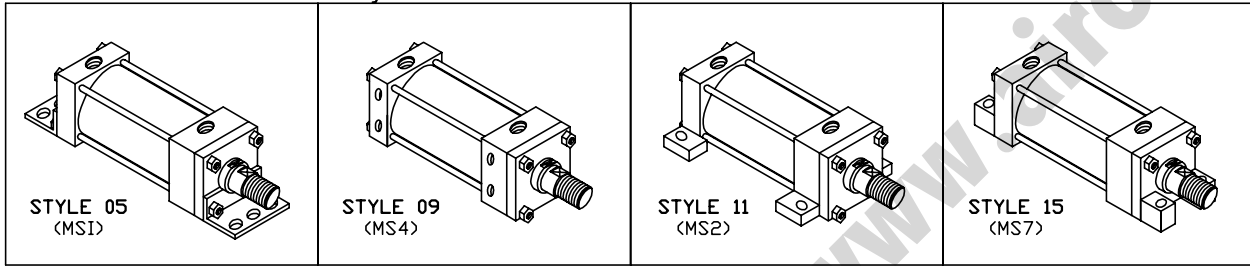

## CLEVIS, PIVOT and SPHERICAL BEARING MOUNT Cylinders

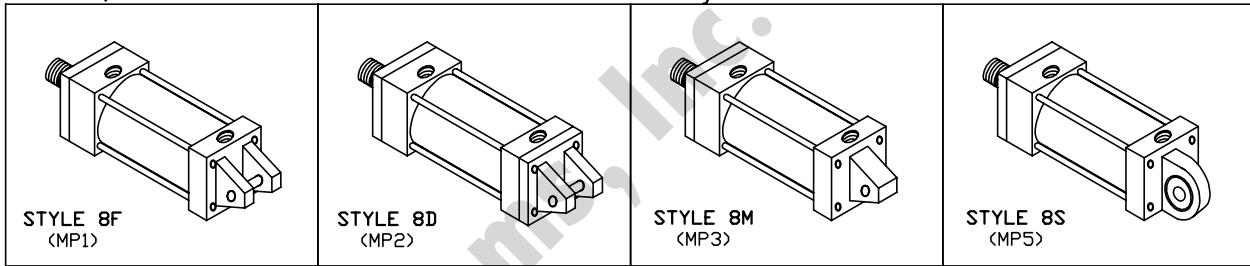

## FLANGE MOUNT Cylinders

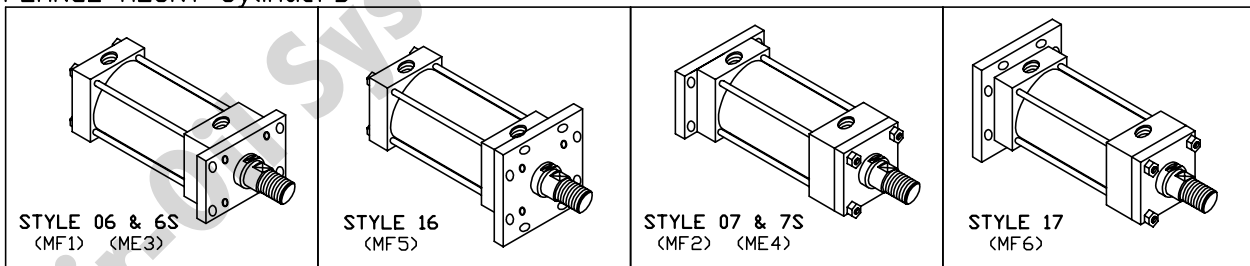

## TRUNNION MOUNT Cylinders

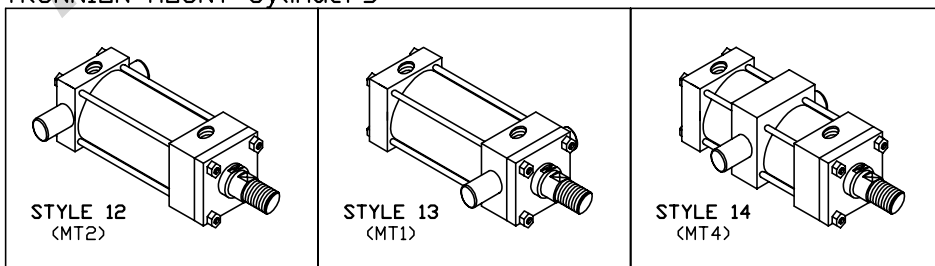



# TABLE OF CONTENTS

<b>Introduction to Lehigh Fluid Power</b> .....	2-3
<b>JHD Air Cylinder Introduction</b> .....	4-5
<b>LSSL Stainless Steel Air Cylinder Introduction</b> .....	6-7
<b>Mounting Styles</b> .....	8
<b>Small Bore</b>	
3/4" and 1" Bore Series SBA & MSBA.....	10-11
Ordering Information.....	11
<b>1" Bore Tie Rod Style, Series JHD and LSSL</b>	
Flange, Pivot, Trunnion and Nose Mounted Cylinders.....	12-13
<b>1 1/2" to 6" Bore Tie Rod Style, Series JHD and LSSL</b>	
Basic, Tie Rod, Nose Mounted and Double Rod End Cylinders.....	14-15
Foot and Flush Mounted Cylinders.....	16-17
Clevis, Pivot and Spherical Bearing Mount Cylinder.....	18-19
Flange Mounted Cylinders.....	20-21
Trunnion Mounted Cylinders.....	22-23
<b>8" to 12" Bore Tie Rod Style, Series JHD and LSSL</b>	
Basic, Tie Rod and Double Rod End Mounted Cylinders.....	24
Foot and Flush Mounted Cylinders.....	25
Clevis and Spherical Bearing Mount Cylinders.....	26
Flange Mounted Cylinders.....	27
Trunnion Mounted Cylinders.....	28
<b>14" to 20" Bore Tie Rod Style, Series JHD and LSSL</b>	
Basic, Tie Rod and Double Rod End Mounted Cylinders.....	29
Foot and Flush Mounted Cylinders.....	30
Clevis and Trunnion Mount Cylinders.....	31
Flange Mounted Cylinders.....	32
<b>Ordering Information for Series JHD and LSSL</b> .....	33
<b>8" to 20" Bore Valve Actuator, Series VAC</b>	
Tie Rod Mounted Valve Actuators.....	34-35
Ordering Information.....	35
<b>Spring Extend and Spring Return Cylinders</b>	
Description and Application.....	36-37
Ordering Information.....	37
<b>Air Motor and Slide Valve</b>	
1" Bore Air Motor, Series JHDA 01.....	38
1 1/2" to 8" Bore Air Motor, Series JHDA.....	38-39
Ordering Information for Series JHDA.....	39
Slide Valve.....	40
<b>Cylinder Positioning Controls</b>	
Introduction.....	41
Tie Rod Mounted Reed and Hall Effect Limit Switches.....	41-42
Ordering Information for Limit Switches.....	43
Other Positioning Controls.....	44-45
<b>Boosters, Intensifiers and Air/Oil Tanks</b>	
Boosters and Intensifiers.....	46-49
Air/Oil Tanks.....	50
Ordering Information.....	51
<b>Accessories and Technical</b>	
Flanged Rod End.....	52
Self-Aligning Rod Coupling.....	53
Mounting Accessories, Standard.....	54-55
Mounting Accessories, Spherical.....	56-57
Rod Selection Chart.....	58
<b>Forces, Warranty</b> .....	59



## TIE ROD MOUNTED CYLINDERS

### 3/4" AND 1" BORE SBA SERIES AIR CYLINDERS

### 3/4" AND 1" BORE MSBA SERIES LINEAR AIR MOTORS

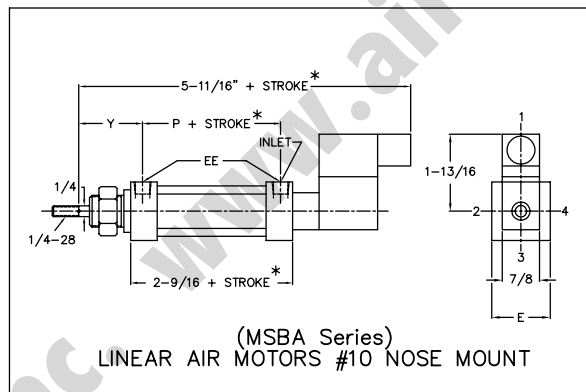
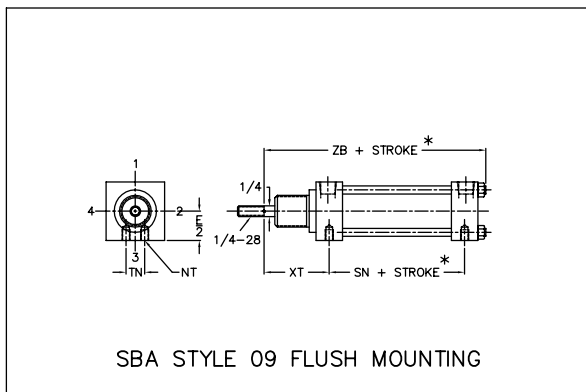
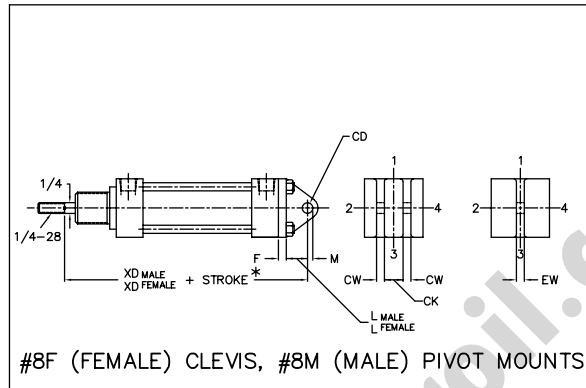
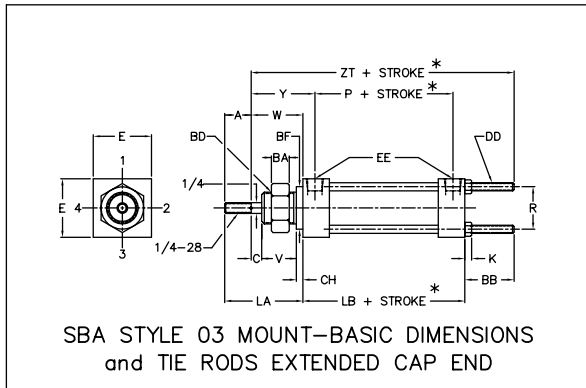

\*For spring return cylinder, add twice stroke to "+ stroke" dimension

### Miracalube® Small Bore Air Cylinders and Small Bore Linear Air Motors

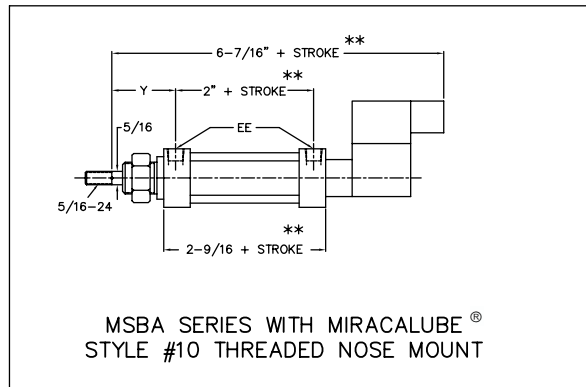
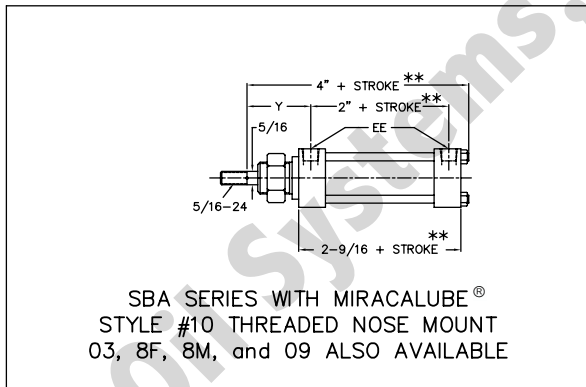

\*\*For spring return cylinder, add 3/4" to "+ stroke" dimension

### ENVELOPE AND MOUNTING DIMENSIONS NOT AFFECTED BY ROD DIAMETER

Bore	BB	CD	CH	CK	CW	DD	E	EE (NPT)	EW	F	K	L Male	L Female
3/4	1 5/32	.250	5/32	7/32	3/16	#8-32	1 1/8	1/8	3/16	3/16	5/32	5/16	1/2
1	1 5/32	.250	5/32	7/32	3/16	#10-32	1 3/8	1/8	3/16	3/16	5/32	5/16	1/2

Bore	LB	NT	P	R	SN	TN	XD Male	XD Female	XT	Y	ZB	ZT
3/4	1 13/16	#10-32	1 1/4	13/16	1 3/16	7/16	3 17/32	3 23/32	1 17/32	1 1/2	3 1/4	4 3/16
1	1 13/16	#10-32	1 1/4	1	1 3/16	7/16	3 17/32	3 23/32	1 17/32	1 1/2	3 1/4	4 3/16

Note: All SBA and MSBA series cylinders are furnished with style 10 threaded nose mount and nut in addition to other available mounts

For pneumatic service to 150 PSI

## TIE ROD MOUNTED CYLINDERS (Cont.)

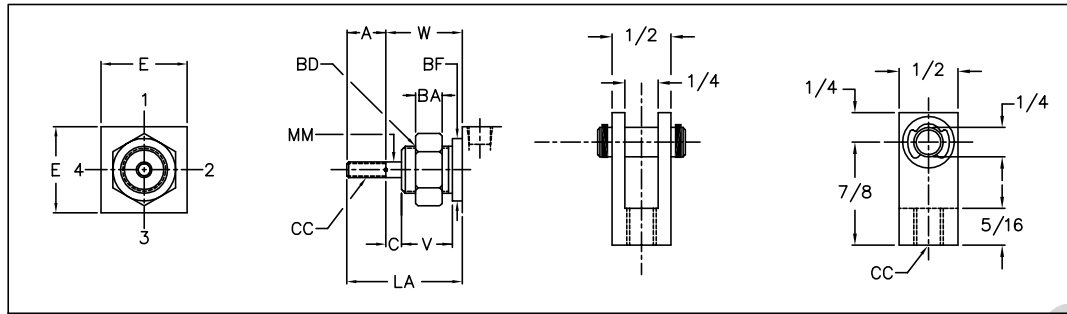

**ROD END DIMENSIONS**

Rod Dia. MM	A	BA	BD	BF	C	CC	E	LA	V	W
1/4	5/8	7/16	3/4-16	1	1/4	1/4-28	1 1/8	1 27/32	13/16	1 7/32
5/16	5/8	7/16	3/4-16	1	1/4	5/16-24	1 3/8	1 27/32	13/16	1 7/32

**Description:** Small Bore Air Cylinders and Linear Air Motors are designed to be used as components of machines or other applications where reliability in rugged service is the prime consideration. These units are built to operate without maintenance for millions of high-speed cycles because of the combined features which are standard only in Lehigh Heavy Duty Cylinders.

### Standard Construction Features: SBA and MSBA Series

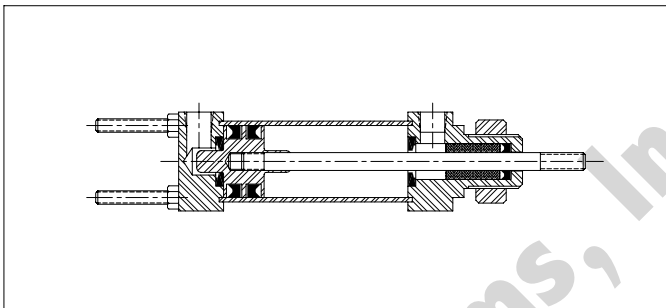

- Fast break-away, lip type cushion seals (on all double acting cylinders)
- Strong, special alloy, low inertia piston rod for high speed service
- Long Oilite piston rod bearing for impact resistance
- Steel heads and pistons for impact resistance
- 1/8" NPT ports, unrestricted for full flow
- Low friction U-cup piston and piston rod seals for long life and speed of response
- Smooth tempered brass tubing for corrosion resistance
- High tensile tie rods

#### Additional Feature for MSBA Series

- Valve-in-head construction simplifies installation by direct connection of electric and air lines to cylinder

#### MSBA Electrical Specifications

- Miniature 3-way solenoid operated valve
- 6 watts power consumption
- 110 volt 60 Hz standard
- Spade terminal coil with ground per DIN 43650
- Continuous duty rated, Class A, molded coil
- Voltages include: 24, 120, 240, 480 VAC  
Other voltages available

### Ordering Information

PRODUCT DESIGNATION	DESCRIPTION
<b>SBA 34</b>	3/4" Bore Standard Cylinder
<b>SBA 34S</b>	3/4" Bore Cylinder, Spring Return
<b>MSBA 34S</b>	3/4" Bore Linear Air Motor, Spring Return
<b>MSBA 34AR</b>	3/4" Bore Linear Air Motor, Air Return
<b>SBA 100</b>	1" Bore Standard Cylinder
<b>SBA 100S</b>	1" Bore Cylinder, Spring Return
<b>MSBA 100S</b>	1" Bore Linear Air Motor, Spring Return
<b>MSBA 100AR</b>	1" Bore Linear Air Motor, Air Return

- Cylinders are furnished with cushions both ends, except spring return
- Standard port position is #1

#### **Select Product Designation and also specify:**

- Standard design or with MIRACALUBE®
- Stroke length
- Mounting style (Note: #10 nose mount with nut is provided as standard, and in addition to optional second mount)



# TIE ROD, FLUSH, NOSE AND FOOT MOUNTED CYLINDERS

## 1" BORE SERIES JHD AND LSSL AIR CYLINDERS

STANDARD IN BRASS TUBE DESIGN AND ALL STAINLESS STEEL DESIGN!

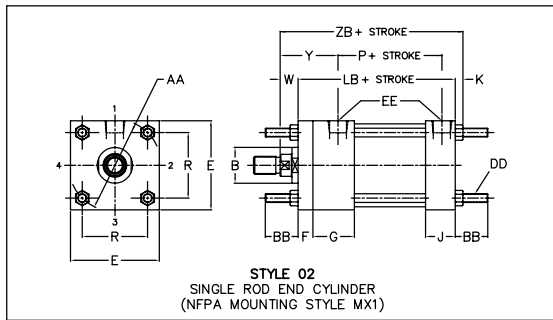

Standard Port location is Position 1,  
Standard Cushion location Position 2.

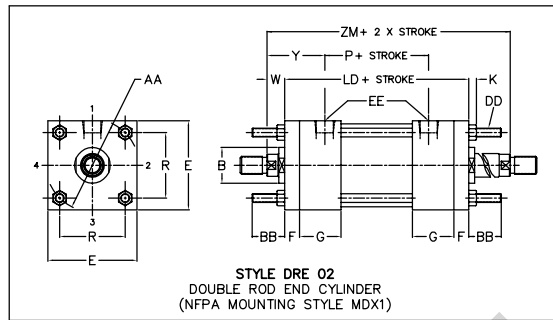

Standard Port location is Position 1,  
Standard Cushion location Position 2.

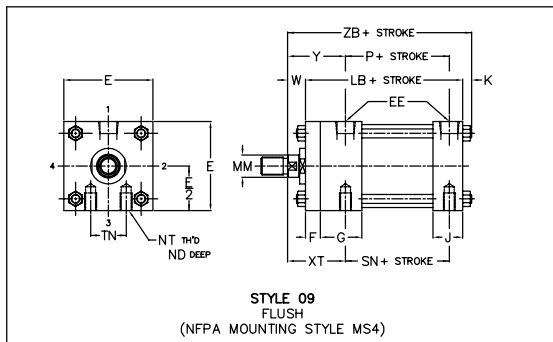

Standard Port location is Position 1,  
Standard Cushion location Position 2.

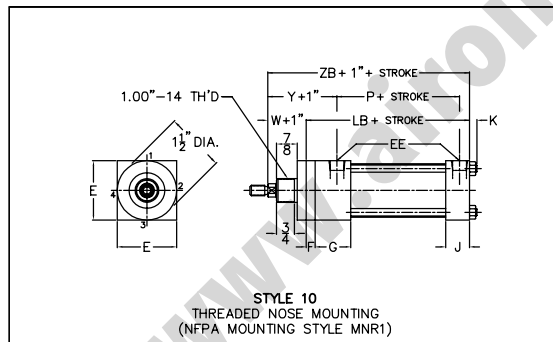

Standard Port location is Position 1,  
Standard Cushion location Position 2.

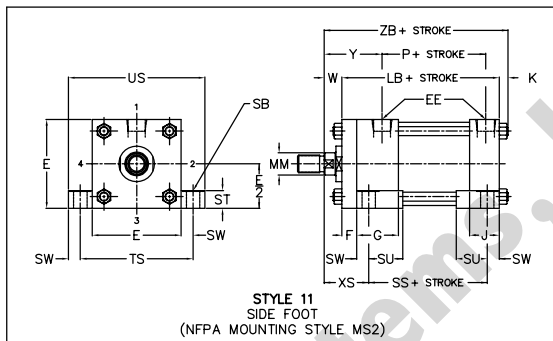

Standard Port location is Position 1,  
Standard Cushion location Position 2.

### TIE ROD MOUNTING DESCRIPTION

MOUNTING STYLE	NFFPA MOUNTING STYLE	DESCRIPTION
01	MX0	NO TIE ROD EXTENSIONS
02	MX1	TIE RODS EXTENDED BOTH ENDS
03	MX2	TIE RODS EXTENDED CAP END
04	MX3	TIE RODS EXTENDED ROD END
DRE 01	MDX0	NO TIE ROD EXTENSIONS
DRE 02	MDX1	TIE RODS EXTENDED BOTH ENDS
DRE 03	MDX3	TIE RODS EXTENDED ONE END

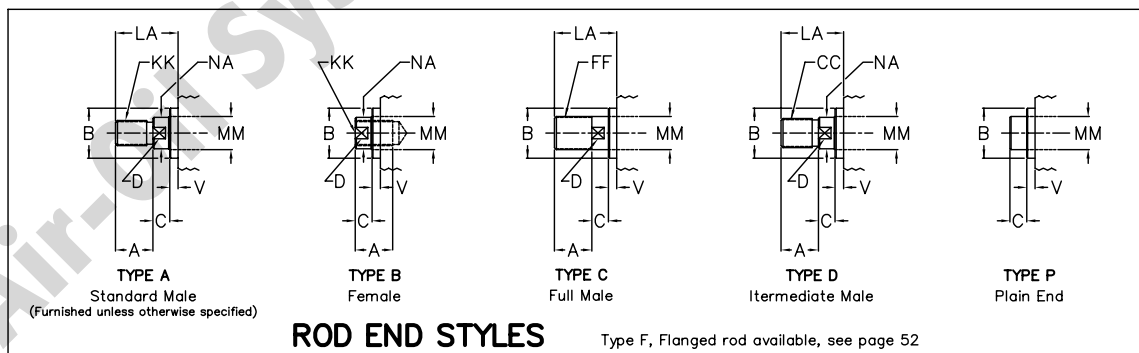

### DIMENSIONS AFFECTED BY ROD DIAMETER

BORE	ROD DIA. MM	THREAD SIZE			ROD EXTENSIONS & PILOT DIMENSIONS						
		KK STD	CC	FF	A	B +.000 -.002	C	D	LA	NA	V
1	1/2	5/16-24	7/16-20	1/2-20	5/8	.999	3/8	3/8	1 1/4	7/16	1/4
	5/8	7/16-20	1/2-20	5/8-18	3/4	1.124	3/8	1/2	1 3/8	9/16	1/4



# FLANGE, CLEVIS PIVOT AND TRUNNION MOUNTED CYLINDERS

## 1" BORE SERIES JHD AND LSSL AIR CYLINDERS (Cont.)

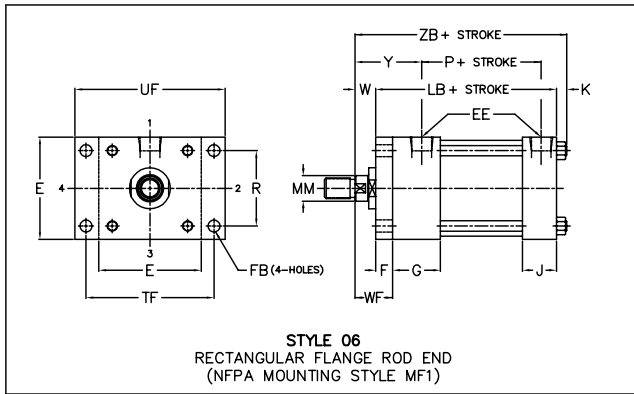

Standard Port location is Position 1.  
Standard Cushion location Position 2.

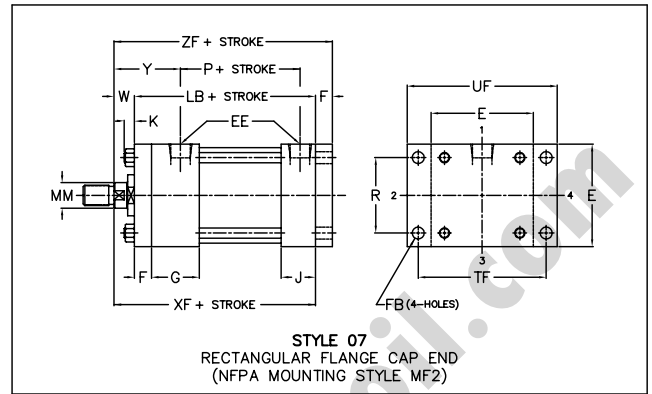

Standard Port location is Position 1.  
Standard Cushion location Position 2.

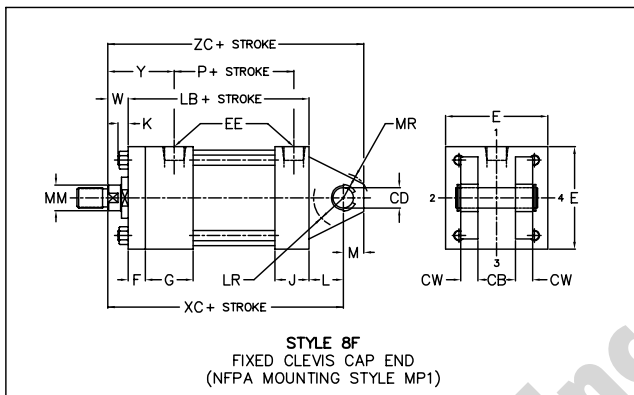

Standard Port location is Position 1.  
Standard Cushion location Position 2.

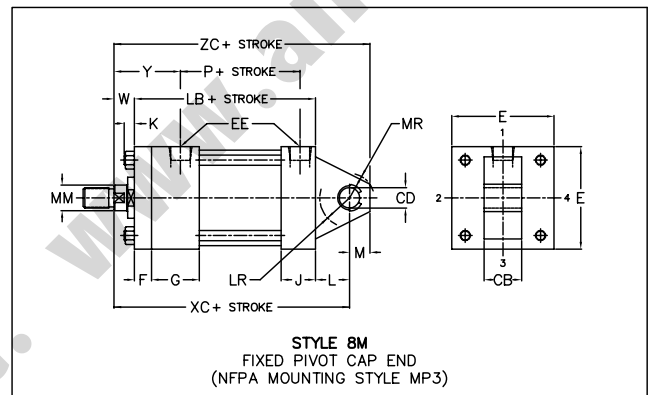

Standard Port location is Position 1.  
Standard Cushion location Position 2.

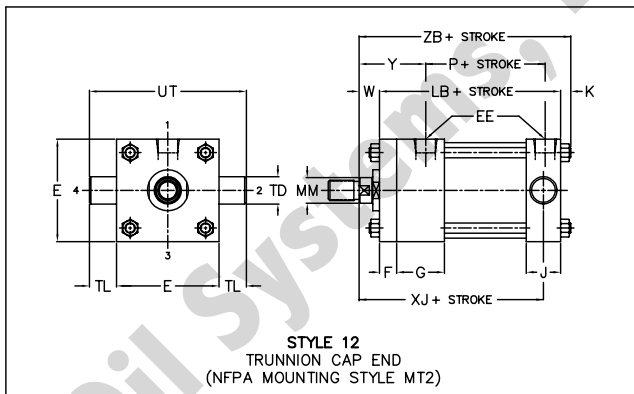

Standard Port location is Position 1.  
Standard Cushion location Position #2, ROD END, Position #3, CAP END

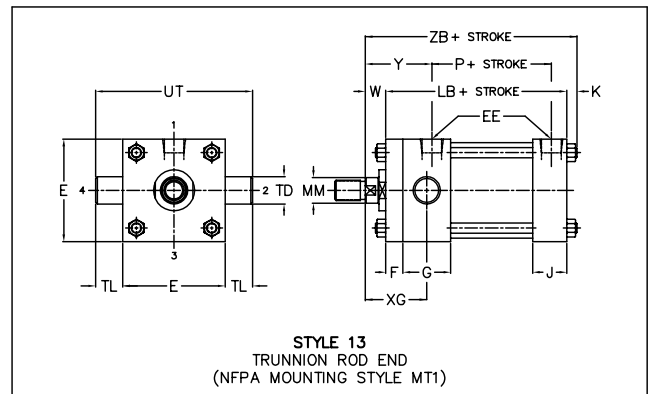

Standard Port location is Position 1.  
Standard Cushion location Position #3, ROD END, Position #2, CAP END

## ENVELOPE AND MOUNTING DIMENSIONS NOT AFFECTED BY ROD DIAMETER

BORE	AA	BB	CB	CD* +.000 -.002	CW	DD	E	EE*		F	FB	G	J	K	L	LR	M	MR
								NPT	SAE									
1	1.53	3/4	7/16	.437	.375	#10-32	1 1/2	1/4	4	3/8	1/4	1 1/2	1	1/8	1/2	7/16	7/16	1/2

BORE	ND	NT	R	SB	ST	SU	SW	TD +.000 -.002	TF	TL	TN	TS	UF	US	UT	W
1	1/4	#10-24	1.08	9/32	5/16	3/4	5/16	.750	2	3/4	9/16	2 1/8	2 1/2	2 3/4	3	5/8

BORE	XG	XS	XT	Y	LB	LD	P	SN	SS	XC	XF	XJ	ZB	ZC	ZF	ZM ADD 2X STROKE
																6
1	1 3/4	1 5/16	1 15/16	1 15/16	3 7/8	4 3/4	2 1/8	2 1/8	2 7/8	5	4 1/2	4	4 5/8	5 7/16	4 7/8	6

\* CD IS PIN DIAMETER

\*\* NPT PORTS FURNISHED UNLESS OTHERWISE SPECIFIED

NOTES: NON ADJUSTABLE CUSHIONS ARE AVAILABLE IN ALL MOUNTINGS FOR BOTH ROD AND CAP ENDS  
FOR MIRACALUBE, CONSULT FACTORY



# TIE ROD AND NOSE MOUNTED CYLINDERS

## 1 1/2" TO 6" BORE SERIES JHD AND LSSL AIR CYLINDERS

**STANDARD IN BRASS TUBE DESIGN AND ALL STAINLESS STEEL DESIGN!**

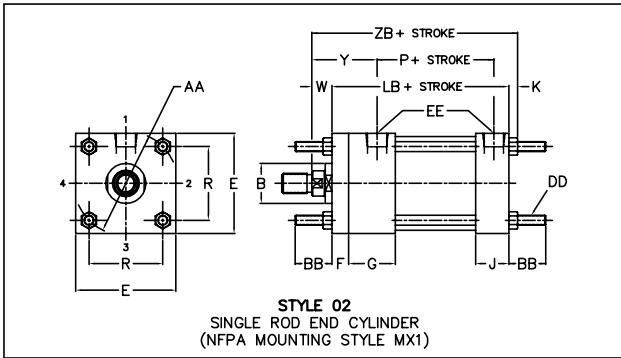

Standard Port location in Position 1.  
Standard Cushion location Position 2.

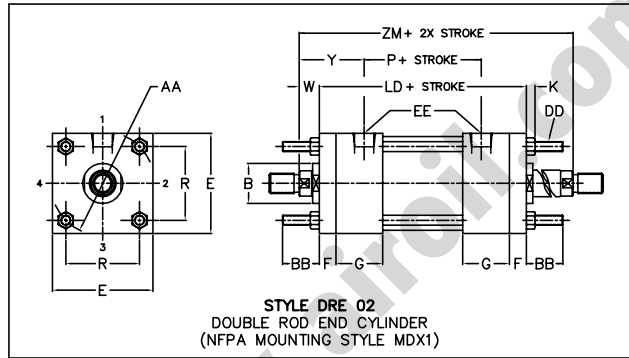

Standard Port location in Position 1.  
Standard Cushion location Position 2.

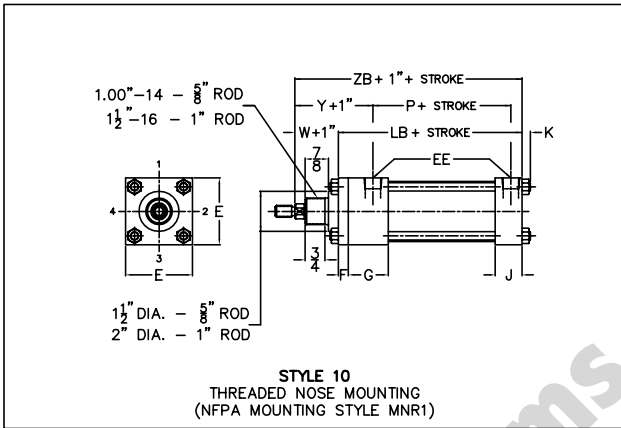

Standard Port location in Position 1.  
Standard Cushion location Position 2.

NOTE: For 1-1/2", 2", 2-1/2"  
cylinder only with 5/8"  
and 1" rod sizes only

### TIE ROD MOUNTING DESCRIPTION

MOUNTING STYLE	NFPA MOUNTING STYLE	DESCRIPTION
01	MX0	NO TIE ROD EXTENSIONS
02	MX1	TIE RODS EXTENDED BOTH ENDS
03	MX2	TIE RODS EXTENDED CAP END
04	MX3	TIE RODS EXTENDED ROD END
DRE 01	MDX0	NO TIE ROD EXTENSIONS
DRE 02	MDX1	TIE RODS EXTENDED BOTH ENDS
DRE 03	MDX3	TIE RODS EXTENDED ONE END

### ENVELOPE AND MOUNTING DIMENSIONS NOT AFFECTED BY ROD DIAMETER

BORE	AA	BB	DD	E	EE *		F	G	J	K	R	LB	LD	P
					NPTF	SAE								
1 1/2	2.02	1	1/4-28	2	3/8	6	3/8	1 1/2	1	1/4	1.43	4	4 7/8	2 1/4
2	2.60	1 1/8	5/16-24	2 1/2	3/8	6	3/8	1 1/2	1	5/16	1.84	4	4 7/8	2 1/4
2 1/2	3.10	1 1/8	5/16-24	3	3/8	6	3/8	1 1/2	1	5/16	2.19	4 1/8	5	2 3/8
3 1/4	3.90	1 3/8	3/8-24	3 3/4	1/2	10	5/8	1 3/4	1 1/4	3/8	2.76	4 7/8	6	2 5/8
4	4.70	1 3/8	3/8-24	4 1/2	1/2	10	5/8	1 3/4	1 1/4	3/8	3.32	4 7/8	6	2 5/8
5	5.80	1 13/16	1/2-20	5 1/2	1/2	10	5/8	1 3/4	1 1/4	7/16	4.10	5 1/8	6 1/4	2 7/8
6	6.90	1 13/16	1/2-20	6 1/2	3/4	12	3/4	2	1 1/2	7/16	4.88	5 3/4	7	3 1/8

\* NPTF PORTS FURNISHED UNLESS OTHERWISE SPECIFIED

## TIE ROD AND NOSE MOUNTED CYLINDERS (Cont.)

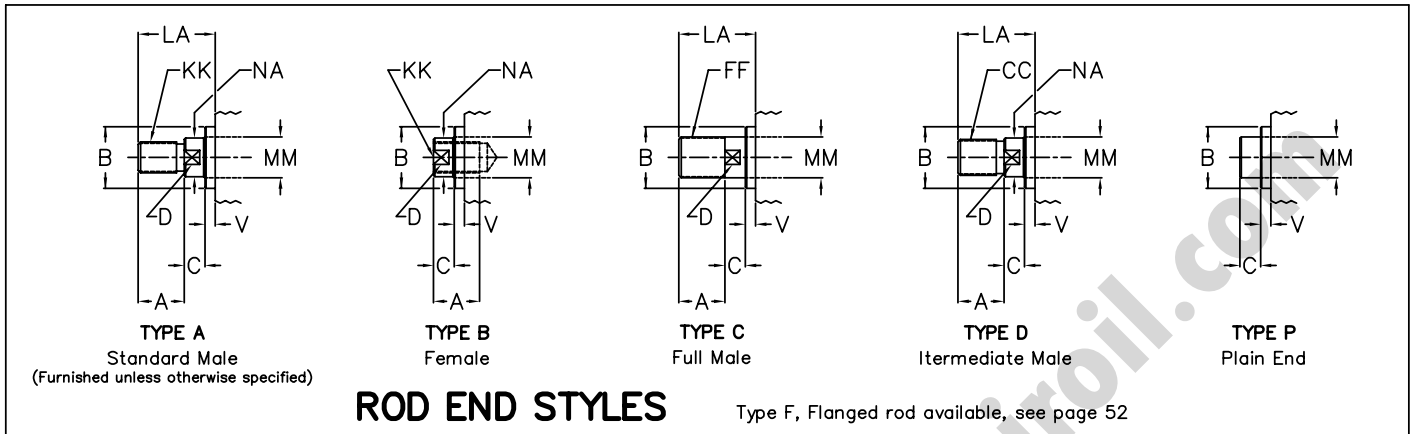

### DIMENSIONS AFFECTED BY ROD DIAMETER

BORE	ROD DIA. MM	THREAD SIZE			ROD AND PILOT DIMENSIONS							ENVELOPE DIMENSIONS			
		KK STD	CC	FF	A	B +.000 -.002	C	D	LA	NA	V	W	Y	ZB ADD STROKE	ZM ADD 2X STROKE
1 1/2	5/8	7/16-20	1/2-20	5/8-18	3/4	1.124	3/8	1/2	1 3/8	9/16	1/4	5/8	1 15/16	4 7/8	6 1/8
	1 *	3/4-16	7/8-14	1-14	1 1/8	1.499	1/2	7/8	2 1/8	15/16	1/2	1	2 5/16	5 1/4	6 7/8
2	5/8	7/16-20	1/2-20	5/8-18	3/4	1.124	3/8	1/2	1 3/8	9/16	1/4	5/8	1 15/16	4 15/16	6 1/8
	1	3/4-16	7/8-14	1-14	1 1/8	1.499	1/2	7/8	2 1/8	15/16	1/2	1	2 5/16	5 5/16	6 7/8
	1 3/8 *	1-14	1 1/4-12	1 3/8-12	1 5/8	1.999	5/8	1 1/8	2 7/8	1 5/16	5/8	1 1/4	2 9/16	5 9/16	7 3/8
2 1/2	5/8	7/16-20	1/2-20	5/8-18	3/4	1.124	3/8	1/2	1 3/8	9/16	1/4	5/8	1 15/16	5 1/16	6 1/4
	1	3/4-16	7/8-14	1-14	1 1/8	1.499	1/2	7/8	2 1/8	15/16	1/2	1	2 5/16	5 7/16	7
	1 3/8	1-14	1 1/4-12	1 3/8-12	1 5/8	1.999	5/8	1 1/8	2 7/8	1 5/16	5/8	1 1/4	2 9/16	5 11/16	7 1/2
	1 3/4 *	1 1/4-12	1 1/2-12	1 3/4-12	2	2.374	3/4	1 1/2	3 1/2	1 11/16	3/4	1 1/2	2 13/16	5 15/16	8
3 1/4	1	3/4-16	7/8-14	1-14	1 1/8	1.499	1/2	7/8	1 7/8	15/16	1/4	3/4	2 7/16	6	7 1/2
	1 3/8	1-14	1 1/4-12	1 3/8-12	1 5/8	1.999	5/8	1 1/8	2 5/8	1 5/16	3/8	1	2 11/16	6 1/4	8
	1 3/4	1 1/4-12	1 1/2-12	1 3/4-12	2	2.374	3/4	1 1/2	3 1/4	1 11/16	1/2	1 1/4	2 15/16	6 1/2	8 1/2
	2 *	1 1/2-12	1 3/4-12	2-12	2 1/4	2.624	7/8	1 11/16	3 5/8	1 15/16	1/2	1 3/8	3 1/16	6 5/8	8 3/4
4	1	3/4-16	7/8-14	1-14	1 1/8	1.499	1/2	7/8	1 7/8	15/16	1/4	3/4	2 7/16	6	7 1/2
	1 3/8	1-14	1 1/4-12	1 3/8-12	1 5/8	1.999	5/8	1 1/8	2 5/8	1 5/16	3/8	1	2 11/16	6 1/4	8
	1 3/4	1 1/4-12	1 1/2-12	1 3/4-12	2	2.374	3/4	1 1/2	3 1/4	1 11/16	1/2	1 1/4	2 15/16	6 1/2	8 1/2
	2	1 1/2-12	1 3/4-12	2-12	2 1/4	2.624	7/8	1 11/16	3 5/8	1 15/16	1/2	1 3/8	3 1/16	6 5/8	8 3/4
5	1	3/4-16	7/8-14	1-14	1 1/8	1.499	1/2	7/8	1 7/8	15/16	1/4	3/4	2 7/16	6 5/16	7 3/4
	1 3/8	1-14	1 1/4-12	1 3/8-12	1 5/8	1.999	5/8	1 1/8	2 5/8	1 5/16	3/8	1	2 11/16	6 9/16	8 1/4
	1 3/4	1 1/4-12	1 1/2-12	1 3/4-12	2	2.374	3/4	1 1/2	3 1/4	1 11/16	1/2	1 1/4	2 15/16	6 13/16	8 3/4
	2	1 1/2-12	1 3/4-12	2-12	2 1/4	2.624	7/8	1 11/16	3 5/8	1 15/16	1/2	1 3/8	3 1/16	6 15/16	9
6	1 3/8	1-14	1 1/4-12	1 3/8-12	1 5/8	1.999	5/8	1 1/8	2 1/2	1 5/16	1/4	7/8	2 13/16	7 1/16	8 3/4
	1 3/4	1 1/4-12	1 1/2-12	1 3/4-12	2	2.374	3/4	1 1/2	3 1/8	1 11/16	3/8	1 1/8	3 1/16	7 5/16	9 1/4
	2	1 1/2-12	1 3/4-12	2-12	2 1/4	2.624	7/8	1 11/16	3 1/2	1 15/16	3/8	1 1/4	3 3/16	7 7/16	9 1/2
	2 1/2	1 7/8-12	2 1/4-12	2 1/2-12	3	3.124	1	2 1/16	4 1/2	2 3/8	1/2	1 1/2	3 7/16	7 11/16	10

FIRST ROD SIZE SHOWN FOR EACH BORE SIZE IS STANDARD ROD

\* ROD END CUSHIONS AVAILABLE ONLY AS NON-ADJUSTABLE TYPE - CONSULT LEHIGH



# FOOT AND FLUSH MOUNTED CYLINDERS

## 1 1/2" TO 6" BORE SERIES JHD AND LSSL AIR CYLINDERS

**STANDARD IN BRASS TUBE DESIGN AND ALL STAINLESS STEEL DESIGN!**

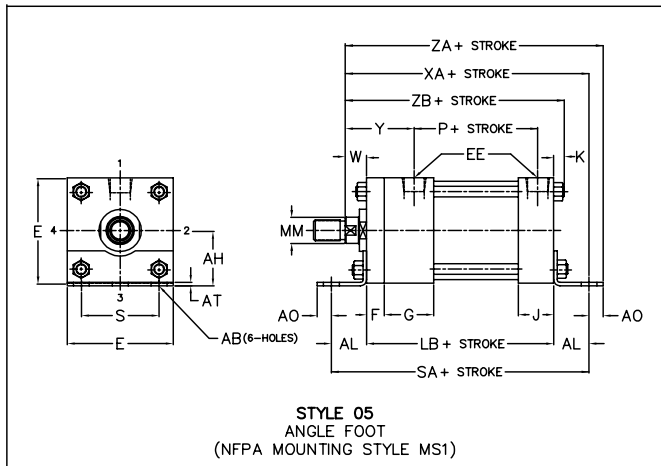

Standard Port location is Position 1.  
Standard Cushion location Position 2.

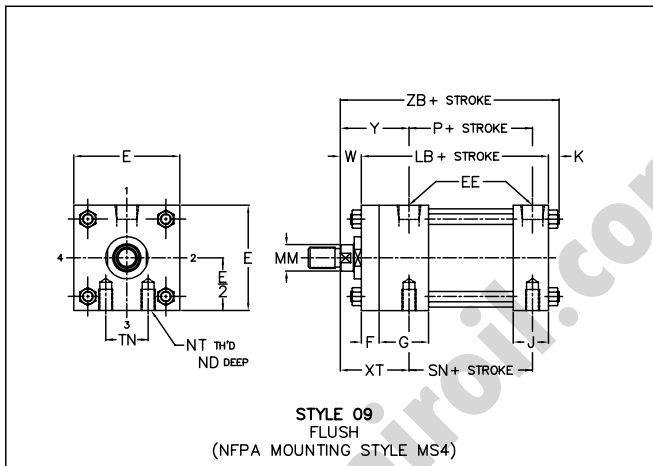

Standard Port location is Position 1.  
Standard Cushion location Position 2.

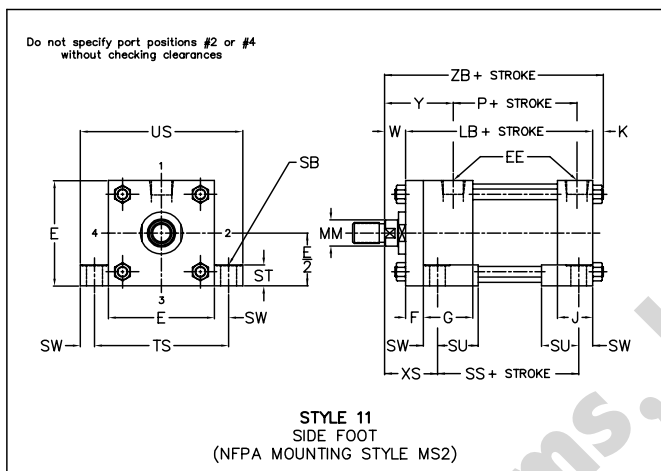

Standard Port location is Position 1.  
Standard Cushion location Position 2.

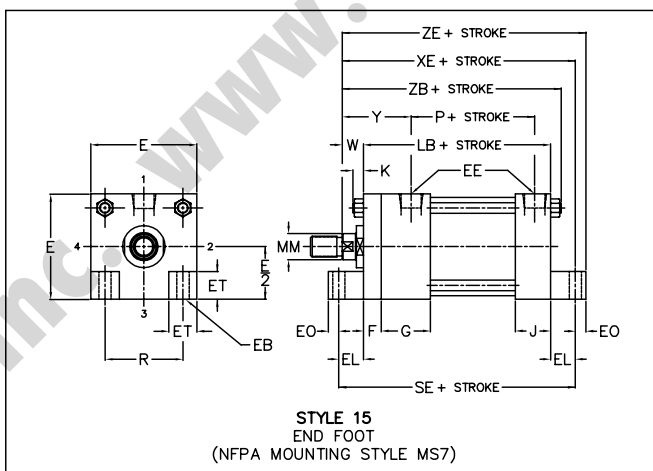

Standard Port location is Position 1.  
Standard Cushion location Position 2.

### ENVELOPE AND MOUNTING DIMENSIONS NOT AFFECTED BY ROD DIAMETER

BORE	AB	AH	AL	AO	AT	E	EB	EE *		EL	EO	ET	F	G	J	K	ND MIN
								NPTF	SAE								
1 1/2	7/16	1 3/16	1	3/8	1/8	2	5/16	3/8	6	3/4	1/4	9/16	3/8	1 1/2	1	1/4	1/4
2	7/16	1 7/16	1	3/8	1/8	2 1/2	3/8	3/8	6	15/16	5/16	11/16	3/8	1 1/2	1	5/16	3/8
2 1/2	7/16	1 5/8	1	3/8	1/8	3	3/8	3/8	6	1 1/16	5/16	13/16	3/8	1 1/2	1	5/16	7/16
3 1/4	9/16	1 15/16	1 1/4	1/2	1/8	3 3/4	7/16	1/2	10	7/8	3/8	1	5/8	1 3/4	1 1/4	3/8	1/2
4	9/16	2 1/4	1 1/4	1/2	1/8	4 1/2	7/16	1/2	10	1	3/8	1 3/16	5/8	1 3/4	1 1/4	3/8	5/8
5	11/16	2 3/4	1 3/8	5/8	3/16	5 1/2	9/16	1/2	10	1 1/16	1/2	1 3/8	5/8	1 3/4	1 1/4	7/16	3/4
6	13/16	3 1/4	1 3/8	5/8	3/16	6 1/2	9/16	3/4	12	1	1/2	1 5/8	3/4	2	1 1/2	7/16	7/8

\* NPTF PORTS FURNISHED UNLESS OTHERWISE SPECIFIED

BORE	NT	R	S	SB	ST	SU	SW	TN	TS	US	LB	P	SA	SE	SN	SS
1 1/2	1/4-20	1.43	1 1/4	7/16	1/2	15/16	3/8	5/8	2 3/4	3 1/2	4	2 1/4	6	5 1/2	2 1/4	2 7/8
2	5/16-18	1.84	1 3/4	7/16	1/2	15/16	3/8	7/8	3 1/4	4	4	2 1/4	6	5 7/8	2 1/4	2 7/8
2 1/2	3/8-16	2.19	2 1/4	7/16	1/2	15/16	3/8	1 1/4	3 3/4	4 1/2	4 1/8	2 3/8	6 1/8	6 1/4	2 3/8	3
3 1/4	1/2-13	2.76	2 3/4	9/16	3/4	1 1/4	1/2	1 1/2	4 3/4	5 3/4	4 7/8	2 5/8	7 3/8	6 5/8	2 5/8	3 1/4
4	1/2-13	3.32	3 1/2	9/16	3/4	1 1/4	1/2	2 1/16	5 1/2	6 1/2	4 7/8	2 5/8	7 3/8	6 7/8	2 5/8	3 1/4
5	5/8-11	4.10	4 1/4	13/16	1	1 9/16	11/16	2 11/16	6 7/8	8 1/4	5 1/8	2 7/8	7 7/8	7 1/4	2 7/8	3 1/8
6	3/4-10	4.88	5 1/4	13/16	1	1 9/16	11/16	3 1/4	7 7/8	9 1/4	5 3/4	3 1/8	8 1/2	7 3/4	3 1/8	3 5/8



# FOOT AND FLUSH MOUNTED CYLINDERS (Cont.)

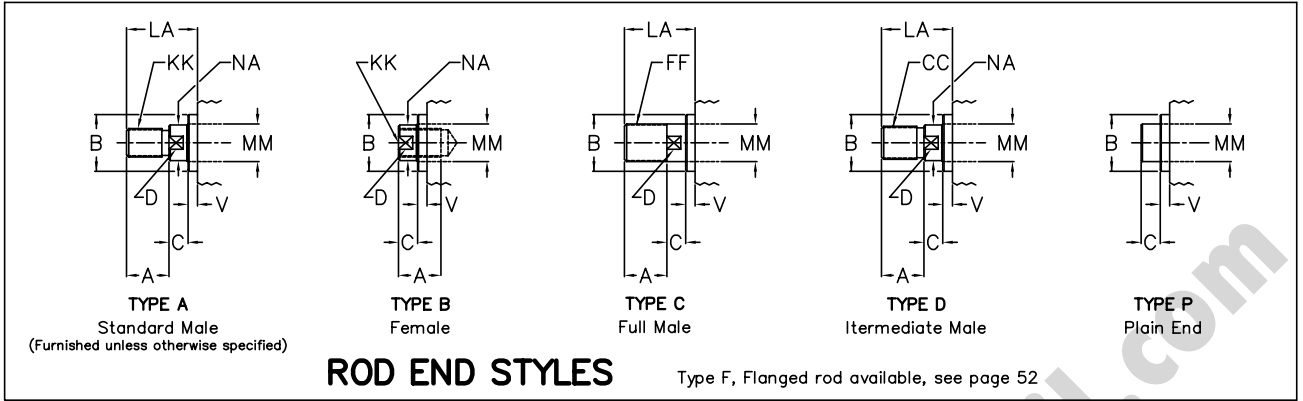

## DIMENSIONS AFFECTED BY ROD DIAMETER

BORE	ROD DIA. MM	THREAD SIZE			ROD AND PILOT DIMENSIONS								ENVELOPE DIMENSIONS										
		KK STD	CC	FF	A	B +0.000 -0.002	C	D	LA	NA	V	W	XS	XT	Y	XA	XE	ZA	ZB	ZE			
																				ADD STROKE			
1 1/2	5/8	7/16-20	1/2-20	5/8-18	3/4	1.124	3/8	1/2	1 3/8	9/16	1/4	5/8	1 3/8	1 15/16	1 15/16	5 5/8	5 3/8	6	4 7/8	5 5/8			
	1 *	3/4-16	7/8-14	1-14	1 1/8	1.499	1/2	7/8	2 1/8	15/16	1/2	1	1 3/4	2 5/16	2 5/16	6	5 3/4	6 3/8	5 1/4	6			
2	5/8	7/16-20	1/2-20	5/8-18	3/4	1.124	3/8	1/2	1 3/8	9/16	1/4	5/8	1 3/8	1 15/16	1 15/16	5 5/8	5 9/16	6	4 15/16	5 7/8			
	1	3/4-16	7/8-14	1-14	1 1/8	1.499	1/2	7/8	2 1/8	15/16	1/2	1	1 3/4	2 5/16	2 5/16	6	5 15/16	6 3/8	5 5/16	6 1/4			
	1 3/8 *	1-14	1 1/4-12	1 3/8-12	1 5/8	1.999	5/8	1 1/8	2 7/8	1 5/16	5/8	1 1/4	2	2 9/16	2 9/16	6 1/4	6 3/16	6 5/8	5 9/16	6 1/2			
2 1/2	5/8	7/16-20	1/2-20	5/8-18	3/4	1.124	3/8	1/2	1 3/8	9/16	1/4	5/8	1 3/8	1 15/16	1 15/16	5 3/4	5 13/16	6 1/8	5 1/16	6 1/8			
	1	3/4-16	7/8-14	1-14	1 1/8	1.499	1/2	7/8	2 1/8	15/16	1/2	1	1 3/4	2 5/16	2 5/16	6 1/8	6 3/16	6 1/2	5 7/16	6 1/2			
	1 3/8	1-14	1 1/4-12	1 3/8-12	1 5/8	1.999	5/8	1 1/8	2 7/8	1 5/16	5/8	1 1/4	2	2 9/16	2 9/16	6 3/8	6 7/16	6 3/4	5 11/16	6 3/4			
	1 3/4 *	1 1/4-12	1 1/2-12	1 3/4-12	2	2.374	3/4	1 1/2	3 1/2	1 11/16	3/4	1 1/2	2 1/4	2 13/16	2 13/16	6 5/8	6 11/16	7	5 15/16	7			
3 1/4	1	3/4-16	7/8-14	1-14	1 1/8	1.499	1/2	7/8	1 7/8	15/16	1/4	3/4	1 7/8	2 7/16	2 7/16	6 7/8	6 1/2	7 3/8	6	6 7/8			
	1 3/8	1-14	1 1/4-12	1 3/8-12	1 5/8	1.999	5/8	1 1/8	2 5/8	1 5/16	3/8	1	2 1/8	2 11/16	2 11/16	7 1/8	6 3/4	7 5/8	6 1/4	7 1/8			
	1 3/4	1 1/4-12	1 1/2-12	1 3/4-12	2	2.374	3/4	1 1/2	3 1/4	1 11/16	1/2	1 1/4	2 3/8	2 15/16	2 15/16	7 3/8	7	7 7/8	6 1/2	7 3/8			
	2 *	1 1/2-12	1 3/4-12	2-12	2 1/4	2.624	7/8	1 11/16	3 5/8	1 15/16	1/2	1 3/8	2 1/2	3 1/16	3 1/16	7 1/2	7 1/8	8	6 5/8	7 1/2			
4	1	3/4-16	7/8-14	1-14	1 1/8	1.499	1/2	7/8	1 7/8	15/16	1/4	3/4	1 7/8	2 7/16	2 7/16	6 7/8	6 5/8	7 3/8	6	7			
	1 3/8	1-14	1 1/4-12	1 3/8-12	1 5/8	1.999	5/8	1 1/8	2 5/8	1 5/16	3/8	1	2 1/8	2 11/16	2 11/16	7 1/8	6 7/8	7 5/8	6 1/4	7 1/4			
	1 3/4	1 1/4-12	1 1/2-12	1 3/4-12	2	2.374	3/4	1 1/2	3 1/4	1 11/16	1/2	1 1/4	2 3/8	2 15/16	2 15/16	7 3/8	7 1/8	7 7/8	6 1/2	7 1/2			
	2	1 1/2-12	1 3/4-12	2-12	2 1/4	2.624	7/8	1 11/16	3 5/8	1 15/16	1/2	1 3/8	2 1/2	3 1/16	3 1/16	7 1/2	7 1/4	8	6 5/8	7 5/8			
5	1	3/4-16	7/8-14	1-14	1 1/8	1.499	1/2	7/8	1 7/8	15/16	1/4	3/4	2 1/16	2 7/16	2 7/16	7 1/4	6 15/16	7 7/8	6 5/16	7 7/16			
	1 3/8	1-14	1 1/4-12	1 3/8-12	1 5/8	1.999	5/8	1 1/8	2 5/8	1 5/16	3/8	1	2 5/16	2 11/16	2 11/16	7 1/2	7 3/16	8 1/8	6 9/16	7 11/16			
	1 3/4	1 1/4-12	1 1/2-12	1 3/4-12	2	2.374	3/4	1 1/2	3 1/4	1 11/16	1/2	1 1/4	2 9/16	2 15/16	2 15/16	7 3/4	7 7/16	8 3/8	6 13/16	7 15/16			
	2	1 1/2-12	1 3/4-12	2-12	2 1/4	2.624	7/8	1 11/16	3 5/8	1 15/16	1/2	1 3/8	2 11/16	3 1/16	3 1/16	7 7/8	7 9/16	8 1/2	6 15/16	8 1/16			
6	1 3/8	1-14	1 1/4-12	1 3/8-12	1 5/8	1.999	5/8	1 1/8	2 1/2	1 5/16	1/4	7/8	2 5/16	2 13/16	2 13/16	8	7 5/8	8 5/8	7 1/16	8 1/8			
	1 3/4	1 1/4-12	1 1/2-12	1 3/4-12	2	2.374	3/4	1 1/2	3 1/8	1 11/16	3/8	1 1/8	2 9/16	3 1/16	3 1/16	8 1/4	7 7/8	8 7/8	7 5/16	8 3/8			
	2	1 1/2-12	1 3/4-12	2-12	2 1/4	2.624	7/8	1 11/16	3 1/2	1 15/16	3/8	1 1/4	2 11/16	3 3/16	3 3/16	8 3/8	8	9	7 7/16	8 1/2			
	2 1/2	1 7/8-12	2 1/4-12	2 1/2-12	3	3.124	1	2 1/16	4 1/2	2 3/8	1/2	1 1/2	2 15/16	3 7/16	3 7/16	8 5/8	8 1/4	9 1/4	7 11/16	8 3/4			

FIRST ROD SIZE SHOWN FOR EACH BORE SIZE IS STANDARD ROD  
 \* ROD END CUSHIONS AVAILABLE ONLY AS NON-ADJUSTABLE TYPE - CONSULT LEIGH

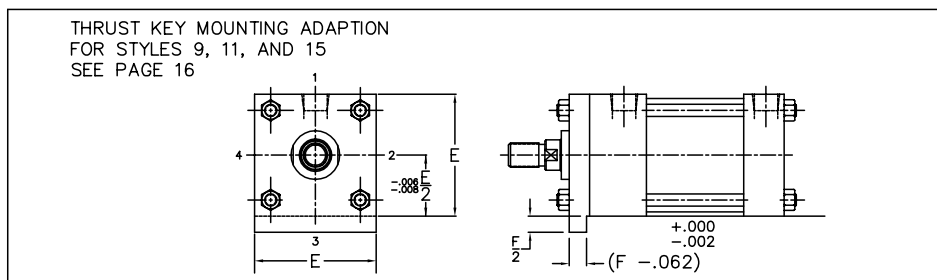



**CLEVIS, PIVOT AND SPHERICAL BEARING MOUNT**  
**1 1/2" TO 6" BORE SERIES JHD AND LSSL AIR CYLINDERS**  
**STANDARD IN BRASS TUBE DESIGN AND ALL STAINLESS STEEL DESIGN!**

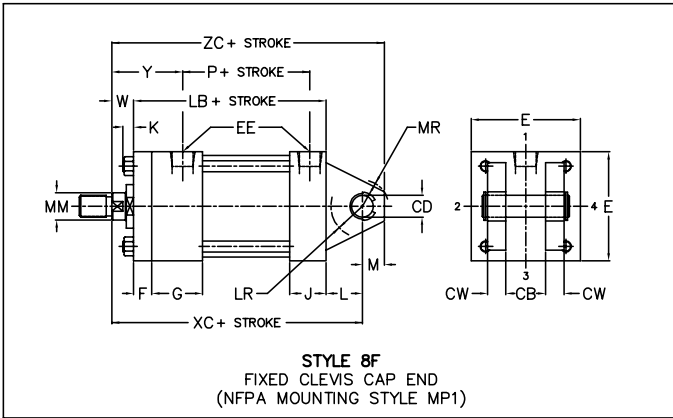

**STYLE 8F**  
**FIXED CLEVIS CAP END**  
**(NFPA MOUNTING STYLE MP1)**

Standard Port location is Position 1.  
 Standard Cushion location Position 2.

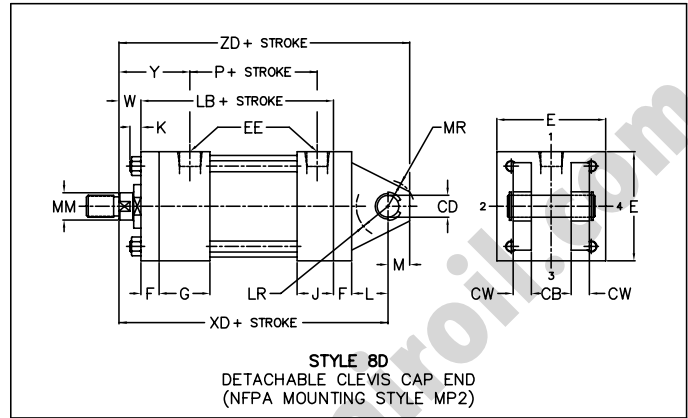

**STYLE 8D**  
**DETACHABLE CLEVIS CAP END**  
**(NFPA MOUNTING STYLE MP2)**

Standard Port location is Position 1.  
 Standard Cushion location Position 2.

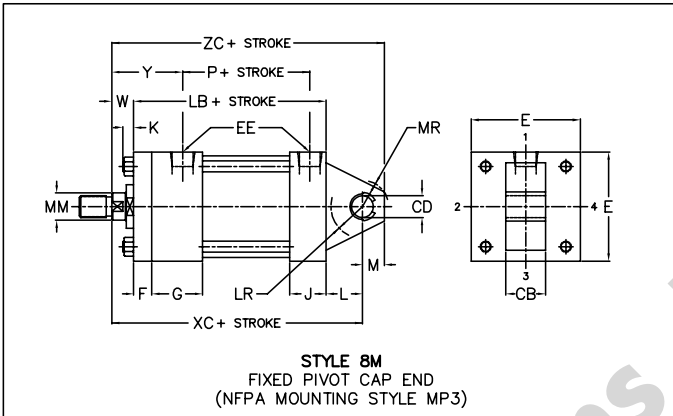

**STYLE 8M**  
**FIXED PIVOT CAP END**  
**(NFPA MOUNTING STYLE MP3)**

Standard Port location is Position 1.  
 Standard Cushion location Position 2.

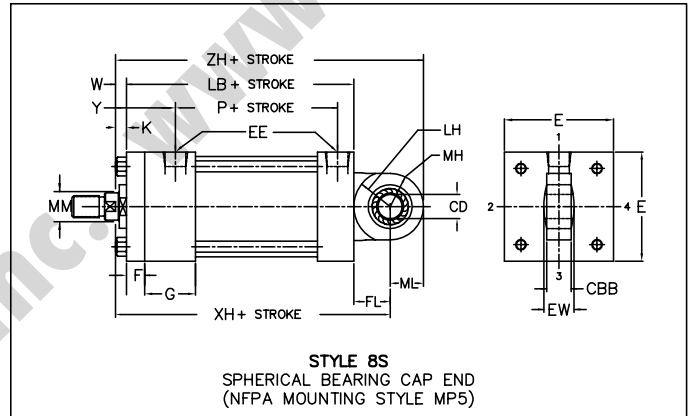

**STYLE 8S**  
**SPHERICAL BEARING CAP END**  
**(NFPA MOUNTING STYLE MP5)**

Standard Port location is Position 1.  
 Standard Cushion location Position 2.

**ENVELOPE AND MOUNTING DIMENSIONS NOT AFFECTED BY ROD DIAMETER**

BORE	CB	CBB	CD** +.000 -.002	CW	E	EE*		EW +.005 -.010	F	FL	G	J	K	L	LH	LR	M	MH	ML	MR	LB	P
						NPTF	SAE															
1 1/2	3/4	3/8	.500	1/2	2	3/8	6	7/16	3/8	3/4	1 1/2	1	1/4	3/4	5/8	3/4	1/2	7/8	15/16	5/8	4	2 1/4
2	3/4	3/8	.500	1/2	2 1/2	3/8	6	7/16	3/8	3/4	1 1/2	1	5/16	3/4	5/8	3/4	1/2	7/8	15/16	5/8	4	2 1/4
2 1/2	3/4	3/8	.500	1/2	3	3/8	6	7/16	3/8	3/4	1 1/2	1	5/16	3/4	5/8	3/4	1/2	7/8	15/16	5/8	4 1/8	2 3/8
3 1/4	1 1/4	9/16	.750	5/8	3 3/4	1/2	10	21/32	5/8	1 1/4	1 3/4	1 1/4	3/8	1 1/4	1	1	3/4	1 3/8	1 5/16	15/16	4 7/8	2 5/8
4	1 1/4	9/16	.750	5/8	4 1/2	1/2	10	21/32	5/8	1 1/4	1 3/4	1 1/4	3/8	1 1/4	1	1	3/4	1 3/8	1 5/16	15/16	4 7/8	2 5/8
5	1 1/4	9/16	.750	5/8	5 1/2	1/2	10	21/32	5/8	1 1/4	1 3/4	1 1/4	7/16	1 1/4	1	1	3/4	1 3/8	1 5/16	15/16	5 1/8	2 7/8
6	1 1/2	3/4	1.000	3/4	6 1/2	3/4	12	7/8	3/4	1 1/2	2	1 1/2	7/16	1 1/2	1 1/4	1 1/4	1	1 1/2	1 1/2	1 3/16	5 3/4	3 1/8

\* NPTF PORTS FURNISHED UNLESS OTHERWISE SPECIFIED  
 \*\* CD IS PIN DIAMETER

Notes: Clevis Pin comes standard with 8F and 8D Mounts  
 Type "B" rod end style is preferred on the 8S style mount cylinder due to the availability of mounting accessories.  
 See pages 54-57 for mounting accessories

# CLEVIS, PIVOT AND SPHERICAL BEARING MOUNT (Cont.)

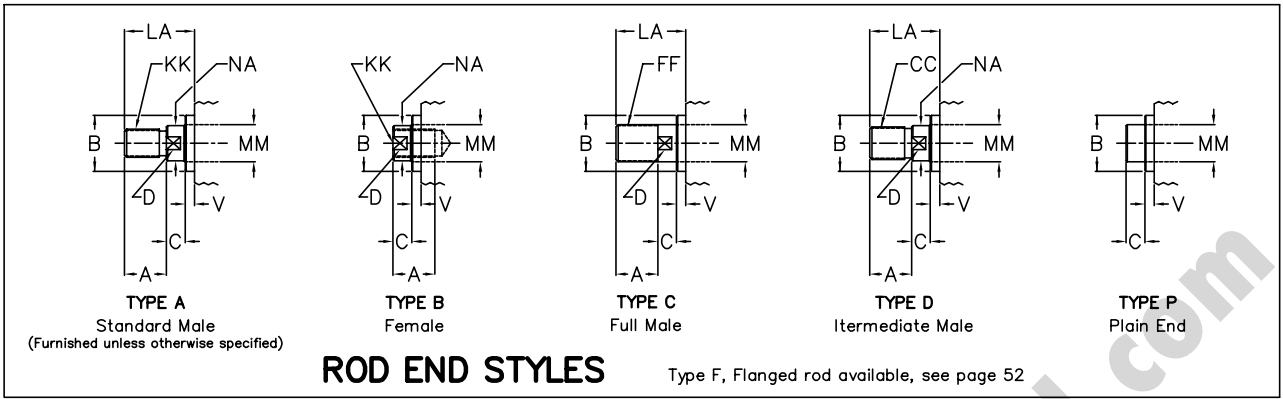

## DIMENSIONS AFFECTED BY ROD DIAMETER

BORE	ROD DIA. MM	THREAD SIZE			ROD AND PILOT DIMENSIONS								ENVELOPE DIMENSIONS						
		KK STD	CC	FF	A	B +0.000 -0.002	C	D	LA	NA	V	W	Y	XC	XD	XH	ZC	ZD	ZH
1 1/2	5/8	7/16-20	1/2-20	5/8-18	3/4	1.124	3/8	1/2	1 3/8	9/16	1/4	5/8	1 15/16	5 3/8	5 3/4	5 3/8	5 7/8	6 1/4	6 5/16
	1 *	3/4-16	7/8-14	1-14	1 1/8	1.499	1/2	7/8	2 1/8	15/16	1/2	1	2 5/16	5 3/4	6 1/8	5 3/4	6 1/4	6 5/8	6 11/16
2	5/8	7/16-20	1/2-20	5/8-18	3/4	1.124	3/8	1/2	1 3/8	9/16	1/4	5/8	1 15/16	5 3/8	5 3/4	5 3/8	5 7/8	6 1/4	6 5/16
	1	3/4-16	7/8-14	1-14	1 1/8	1.499	1/2	7/8	2 1/8	15/16	1/2	1	2 5/16	5 3/4	6 1/8	5 3/4	6 1/4	6 5/8	6 11/16
	1 3/8 *	1-14	1 1/4-12	1 3/8-12	1 5/8	1.999	5/8	1 1/8	2 7/8	1 5/16	5/8	1 1/4	2 9/16	6	6 3/8	6	6 1/2	6 7/8	6 15/16
2 1/2	5/8	7/16-20	1/2-20	5/8-18	3/4	1.124	3/8	1/2	1 3/8	9/16	1/4	5/8	1 15/16	5 1/2	5 7/8	5 1/2	6	6 3/8	6 7/16
	1	3/4-16	7/8-14	1-14	1 1/8	1.499	1/2	7/8	2 1/8	15/16	1/2	1	2 5/16	5 7/8	6 1/4	5 7/8	6 3/8	6 3/4	6 13/16
	1 3/8	1-14	1 1/4-12	1 3/8-12	1 5/8	1.999	5/8	1 1/8	2 7/8	1 5/16	5/8	1 1/4	2 9/16	6 1/8	6 1/2	6 1/8	6 5/8	7	7 1/16
	1 3/4 *	1 1/4-12	1 1/2-12	1 3/4-12	2	2.374	3/4	1 1/2	3 1/2	1 11/16	3/4	1 1/2	2 13/16	6 3/8	6 3/4	6 3/8	6 7/8	7 1/4	7 5/16
3 1/4	1	3/4-16	7/8-14	1-14	1 1/8	1.499	1/2	7/8	1 7/8	15/16	1/4	3/4	2 7/16	6 7/8	7 1/2	6 7/8	7 5/8	8 1/4	8 3/16
	1 3/8	1-14	1 1/4-12	1 3/8-12	1 5/8	1.999	5/8	1 1/8	2 5/8	1 5/16	3/8	1	2 11/16	7 1/8	7 3/4	7 1/8	7 7/8	8 1/2	8 7/16
	1 3/4	1 1/4-12	1 1/2-12	1 3/4-12	2	2.374	3/4	1 1/2	3 1/4	1 11/16	1/2	1 1/4	2 15/16	7 3/8	8	7 3/8	8 1/8	8 3/4	8 11/16
	2 *	1 1/2-12	1 3/4-12	2-12	2 1/4	2.624	7/8	1 11/16	3 5/8	1 15/16	1/2	1 3/8	3 1/16	7 1/2	8 1/8	7 1/2	8 1/4	8 7/8	8 13/16
4	1	3/4-16	7/8-14	1-14	1 1/8	1.499	1/2	7/8	1 7/8	15/16	1/4	3/4	2 7/16	6 7/8	7 1/2	6 7/8	7 5/8	8 1/4	8 3/16
	1 3/8	1-14	1 1/4-12	1 3/8-12	1 5/8	1.999	5/8	1 1/8	2 5/8	1 5/16	3/8	1	2 11/16	7 1/8	7 3/4	7 1/8	7 7/8	8 1/2	8 7/16
	1 3/4	1 1/4-12	1 1/2-12	1 3/4-12	2	2.374	3/4	1 1/2	3 1/4	1 11/16	1/2	1 1/4	2 15/16	7 3/8	8	7 3/8	8 1/8	8 3/4	8 11/16
	2	1 1/2-12	1 3/4-12	2-12	2 1/4	2.624	7/8	1 11/16	3 5/8	1 15/16	1/2	1 3/8	3 1/16	7 1/2	8 1/8	7 1/2	8 1/4	8 7/8	8 13/16
5	1	3/4-16	7/8-14	1-14	1 1/8	1.499	1/2	7/8	1 7/8	15/16	1/4	3/4	2 7/16	6 7/8	7 1/2	6 7/8	7 5/8	8 1/4	8 3/16
	1 3/8	1-14	1 1/4-12	1 3/8-12	1 5/8	1.999	5/8	1 1/8	2 5/8	1 5/16	3/8	1	2 11/16	7 3/8	8	7 3/8	8 1/8	8 3/4	8 11/16
	1 3/4	1 1/4-12	1 1/2-12	1 3/4-12	2	2.374	3/4	1 1/2	3 1/4	1 11/16	1/2	1 1/4	2 15/16	7 5/8	8 1/4	7 5/8	8 3/8	9	8 15/16
	2	1 1/2-12	1 3/4-12	2-12	2 1/4	2.624	7/8	1 11/16	3 5/8	1 15/16	1/2	1 3/8	3 1/16	7 3/4	8 3/8	7 3/4	8 1/2	9 1/8	9 1/16
6	1 3/8	1-14	1 1/4-12	1 3/8-12	1 5/8	1.999	5/8	1 1/8	2 1/2	1 5/16	1/4	7/8	2 13/16	8 1/8	8 7/8	8 1/8	9 1/8	9 7/8	9 5/8
	1 3/4	1 1/4-12	1 1/2-12	1 3/4-12	2	2.374	3/4	1 1/2	3 1/8	1 11/16	3/8	1 1/8	3 1/16	8 3/8	9 1/8	8 3/8	9 3/8	10 1/8	9 7/8
	2	1 1/2-12	1 3/4-12	2-12	2 1/4	2.624	7/8	1 11/16	3 1/2	1 15/16	3/8	1 1/4	3 3/16	8 1/2	9 1/4	8 1/2	9 1/2	10 1/4	10
	2 1/2	1 7/8-12	2 1/4-12	2 1/2-12	3	3.124	1	2 1/16	4 1/2	2 3/8	1/2	1 1/2	3 7/16	8 3/4	9 1/2	8 3/4	9 3/4	10 1/2	10 1/4

FIRST ROD SIZE SHOWN FOR EACH BORE SIZE IS STANDARD ROD  
 \* ROD END CUSHIONS AVAILABLE ONLY AS NON-ADJUSTABLE TYPE - CONSULT LEHIGH

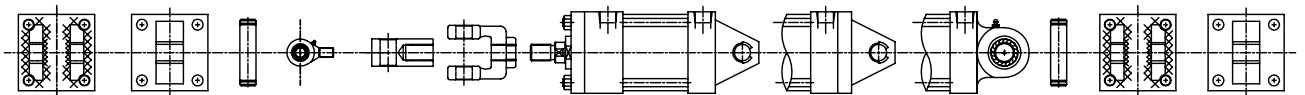

See pp. 54-57 for Mounting Accessories



# FLANGE MOUNTED CYLINDERS

## 1 1/2" TO 6" BORE SERIES JHD AND LSSL AIR CYLINDERS

**STANDARD IN BRASS TUBE DESIGN AND ALL STAINLESS STEEL DESIGN!**

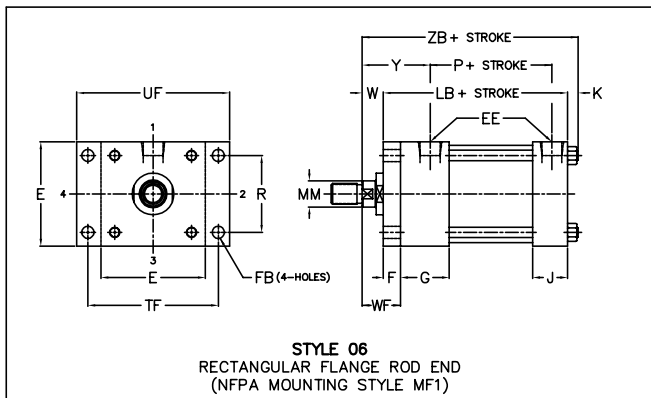

**STYLE 06**  
RECTANGULAR FLANGE ROD END  
(NFPA MOUNTING STYLE MF1)

Standard Port location is Position 1.  
Standard Cushion location Position 2.

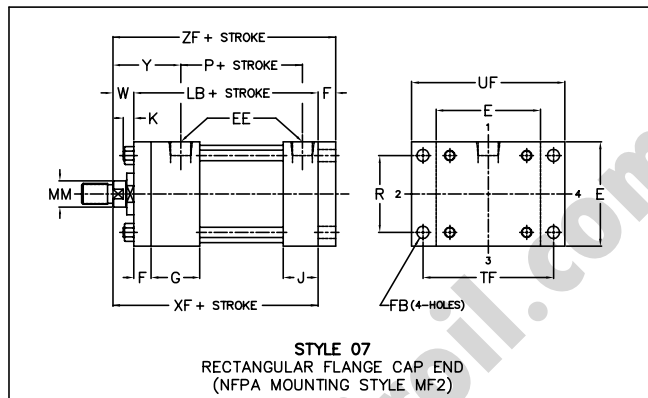

**STYLE 07**  
RECTANGULAR FLANGE CAP END  
(NFPA MOUNTING STYLE MF2)

Standard Port location is Position 1.  
Standard Cushion location Position 2.

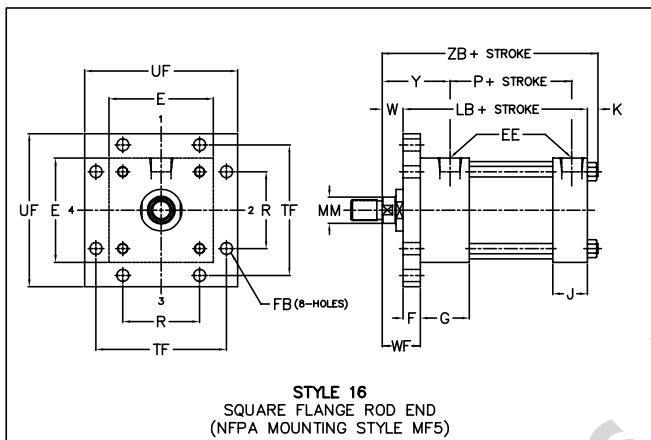

**STYLE 16**  
SQUARE FLANGE ROD END  
(NFPA MOUNTING STYLE MF5)

Standard Port location is Position 1.  
Standard Cushion location Position 2.

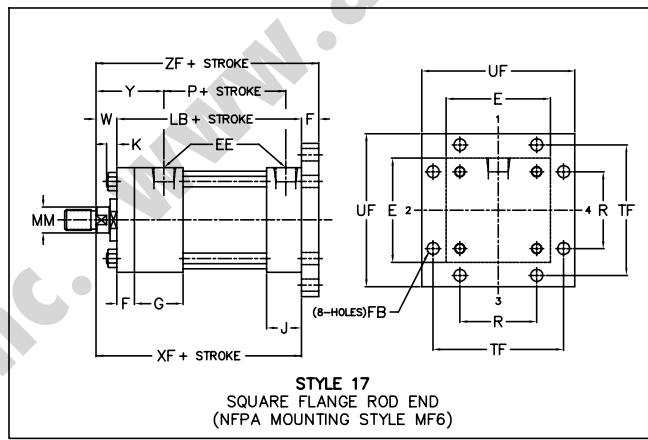

**STYLE 17**  
SQUARE FLANGE ROD END  
(NFPA MOUNTING STYLE MF6)

Standard Port location is Position 1.  
Standard Cushion location Position 2.

### ENVELOPE AND MOUNTING DIMENSIONS NOT AFFECTED BY ROD DIAMETER

BORE	E	EE *		F	FB	G	J	K	R	TF	UF	LB	P
		NPTF	SAE									ADD STROKE	
1 1/2	2	3/8	6	3/8	5/16	1 1/2	1	1/4	1.43	2 3/4	3 3/8	4	2 1/4
2	2 1/2	3/8	6	3/8	3/8	1 1/2	1	5/16	1.84	3 3/8	4 1/8	4	2 1/4
2 1/2	3	3/8	6	3/8	3/8	1 1/2	1	5/16	2.19	3 7/8	4 5/8	4 1/8	2 3/8
3 1/4	3 3/4	1/2	10	5/8	7/16	1 3/4	1 1/4	3/8	2.76	4 11/16	5 1/2	4 7/8	2 5/8
4	4 1/2	1/2	10	5/8	7/16	1 3/4	1 1/4	3/8	3.32	5 7/16	6 1/4	4 7/8	2 5/8
5	5 1/2	1/2	10	5/8	9/16	1 3/4	1 1/4	7/16	4.10	6 5/8	7 5/8	5 1/8	2 7/8
6	6 1/2	3/4	12	3/4	9/16	2	1 1/2	7/16	4.88	7 5/8	8 5/8	5 3/4	3 1/8

\* NPTF PORTS FURNISHED UNLESS OTHERWISE SPECIFIED

## FLANGE MOUNTED CYLINDERS (Cont.)

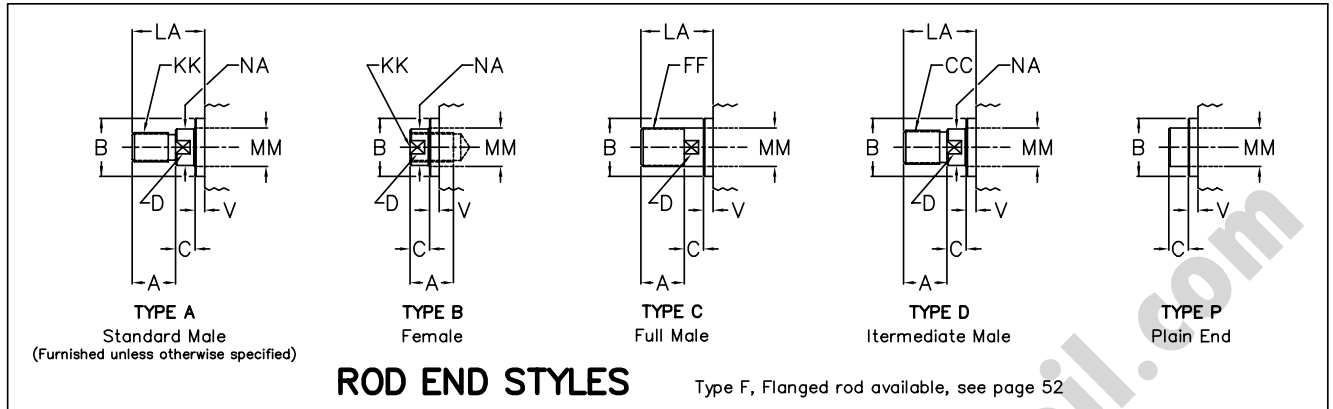

### DIMENSIONS AFFECTED BY ROD DIAMETER

BORE	ROD DIA. MM	THREAD SIZE			ROD AND PILOT DIMENSIONS							ENVELOPE DIMENSIONS					
		KK STD	CC	FF	A	B +0.000 -0.002	C	D	LA	NA	V	W	WF	Y	XF	ZB	ZF
1 1/2	5/8	7/16-20	1/2-20	5/8-18	3/4	1.124	3/8	1/2	1 3/8	9/16	1/4	5/8	1	1 15/16	4 5/8	4 7/8	5
	1 *	3/4-16	7/8-14	1-14	1 1/8	1.499	1/2	7/8	2 1/8	15/16	1/2	1	1 3/8	2 5/16	5	5 1/4	5 3/8
2	5/8	7/16-20	1/2-20	5/8-18	3/4	1.124	3/8	1/2	1 3/8	9/16	1/4	5/8	1	1 15/16	4 5/8	4 15/16	5
	1	3/4-16	7/8-14	1-14	1 1/8	1.499	1/2	7/8	2 1/8	15/16	1/2	1	1 3/8	2 5/16	5	5 5/16	5 3/8
	1 3/8 *	1-14	1 1/4-12	1 3/8-12	1 5/8	1.999	5/8	1 1/8	2 7/8	1 5/16	5/8	1 1/4	1 5/8	2 9/16	5 1/4	5 9/16	5 5/8
2 1/2	5/8	7/16-20	1/2-20	5/8-18	3/4	1.124	3/8	1/2	1 3/8	9/16	1/4	5/8	1	1 15/16	4 3/4	5 1/16	5 1/8
	1	3/4-16	7/8-14	1-14	1 1/8	1.499	1/2	7/8	2 1/8	15/16	1/2	1	1 3/8	2 5/16	5 1/8	5 7/16	5 1/2
	1 3/8	1-14	1 1/4-12	1 3/8-12	1 5/8	1.999	5/8	1 1/8	2 7/8	1 5/16	5/8	1 1/4	1 5/8	2 9/16	5 3/8	5 11/16	5 3/4
	1 3/4 *	1 1/4-12	1 1/2-12	1 3/4-12	2	2.374	3/4	1 1/2	3 1/2	1 11/16	3/4	1 1/2	1 7/8	2 13/16	5 5/8	5 15/16	6
3 1/4	1	3/4-16	7/8-14	1-14	1 1/8	1.499	1/2	7/8	1 7/8	15/16	1/4	3/4	1 3/8	2 7/16	5 5/8	6	6 1/4
	1 3/8	1-14	1 1/4-12	1 3/8-12	1 5/8	1.999	5/8	1 1/8	2 5/8	1 5/16	3/8	1	1 5/8	2 11/16	5 7/8	6 1/4	6 1/2
	1 3/4	1 1/4-12	1 1/2-12	1 3/4-12	2	2.374	3/4	1 1/2	3 1/4	1 11/16	1/2	1 1/4	1 7/8	2 15/16	6 1/8	6 1/2	6 3/4
	2 *	1 1/2-12	1 3/4-12	2-12	2 1/4	2.624	7/8	1 11/16	3 5/8	1 15/16	1/2	1 3/8	2	3 1/16	6 1/4	6 5/8	6 7/8
4	1	3/4-16	7/8-14	1-14	1 1/8	1.499	1/2	7/8	1 7/8	15/16	1/4	3/4	1 3/8	2 7/16	5 5/8	6	6 1/4
	1 3/8	1-14	1 1/4-12	1 3/8-12	1 5/8	1.999	5/8	1 1/8	2 5/8	1 5/16	3/8	1	1 5/8	2 11/16	5 7/8	6 1/4	6 1/2
	1 3/4	1 1/4-12	1 1/2-12	1 3/4-12	2	2.374	3/4	1 1/2	3 1/4	1 11/16	1/2	1 1/4	1 7/8	2 15/16	6 1/8	6 1/2	6 3/4
	2	1 1/2-12	1 3/4-12	2-12	2 1/4	2.624	7/8	1 11/16	3 5/8	1 15/16	1/2	1 3/8	2	3 1/16	6 1/4	6 5/8	6 7/8
5	1	3/4-16	7/8-14	1-14	1 1/8	1.499	1/2	7/8	1 7/8	15/16	1/4	3/4	1 3/8	2 7/16	5 7/8	6 5/16	6 1/2
	1 3/8	1-14	1 1/4-12	1 3/8-12	1 5/8	1.999	5/8	1 1/8	2 5/8	1 5/16	3/8	1	1 5/8	2 11/16	6 1/8	6 9/16	6 3/4
	1 3/4	1 1/4-12	1 1/2-12	1 3/4-12	2	2.374	3/4	1 1/2	3 1/4	1 11/16	1/2	1 1/4	1 7/8	2 15/16	6 3/8	6 13/16	7
	2	1 1/2-12	1 3/4-12	2-12	2 1/4	2.624	7/8	1 11/16	3 5/8	1 15/16	1/2	1 3/8	2	3 1/16	6 1/2	6 15/16	7 1/8
6	1 3/8	1-14	1 1/4-12	1 3/8-12	1 5/8	1.999	5/8	1 1/8	2 1/2	1 5/16	1/4	7/8	1 5/8	2 13/16	6 5/8	7 1/16	7 3/8
	1 3/4	1 1/4-12	1 1/2-12	1 3/4-12	2	2.374	3/4	1 1/2	3 1/8	1 11/16	3/8	1 1/8	1 7/8	3 1/16	6 7/8	7 5/16	7 5/8
	2	1 1/2-12	1 3/4-12	2-12	2 1/4	2.624	7/8	1 11/16	3 1/2	1 15/16	3/8	1 1/4	2	3 3/16	7	7 7/16	7 3/4
	2 1/2	1 7/8-12	2 1/4-12	2 1/2-12	3	3.124	1	2 1/16	4 1/2	2 3/8	1/2	1 1/2	2 1/4	3 7/16	7 1/4	7 11/16	8

FIRST ROD SIZE SHOWN FOR EACH BORE SIZE IS STANDARD ROD

\* ROD END CUSHIONS AVAILABLE ONLY AS NON-ADJUSTABLE TYPE - CONSULT LEHIGH





# TRUNNION MOUNTED CYLINDERS

## 1 1/2" TO 6" BORE SERIES JHD AND LSSL AIR CYLINDERS

**STANDARD IN BRASS TUBE DESIGN AND ALL STAINLESS STEEL DESIGN!**

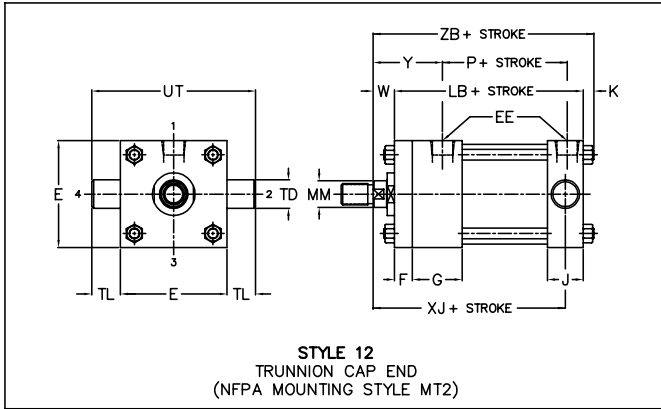

Standard Port location is Position 1.  
Standard Cushion location is Position 2 Rod End, and Position 3 Cap End.

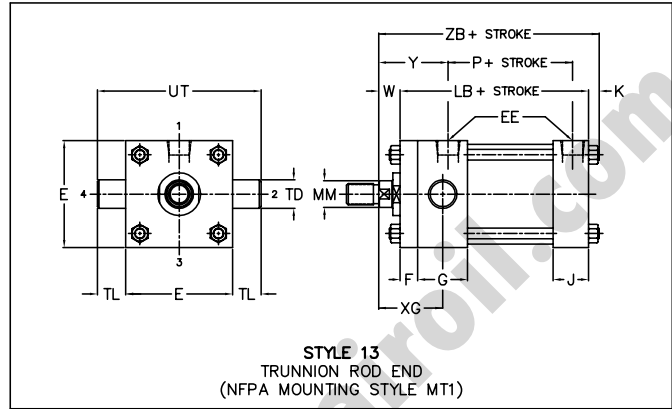

Standard Port location is Position 1.  
Standard Cushion location is Position 3 Rod End, and Position 2 Cap End.

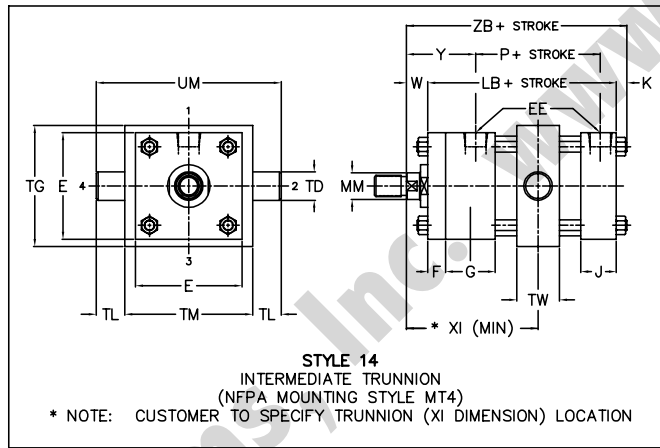

Standard Port location is Position 1.  
Standard Cushion location is Position 2.

### ENVELOPE AND MOUNTING DIMENSIONS NOT AFFECTED BY ROD DIAMETER

BORE	E	EE *		F	G	J	K	TD **	TG	TL	TM	TW	UM	UT	ADD STROKE	
		NPTF	SAE												LB	P
1 1/2	2	3/8	6	3/8	1 1/2	1	1/4	1.000	2 1/2	1	2 1/2	1 1/4	4 1/2	4	4	2 1/4
2	2 1/2	3/8	6	3/8	1 1/2	1	5/16	1.000	3	1	3	1 1/2	5	4 1/2	4	2 1/4
2 1/2	3	3/8	6	3/8	1 1/2	1	5/16	1.000	3 1/2	1	3 1/2	1 1/2	5 1/2	5	4 1/8	2 3/8
3 1/4	3 3/4	1/2	10	5/8	1 3/4	1 1/4	3/8	1.000	4 1/4	1	4 1/2	2	6 1/2	5 3/4	4 7/8	2 5/8
4	4 1/2	1/2	10	5/8	1 3/4	1 1/4	3/8	1.000	5	1	5 1/4	2	7 1/4	6 1/2	4 7/8	2 5/8
5	5 1/2	1/2	10	5/8	1 3/4	1 1/4	7/16	1.000	6	1	6 1/4	2	8 1/4	7 1/2	5 1/8	2 7/8
6	6 1/2	3/4	12	3/4	2	1 1/2	7/16	1.375	7	1 3/8	7 5/8	2 1/2	10 3/8	9 1/4	5 3/4	3 1/8

\* NPTF PORTS FURNISHED UNLESS OTHERWISE SPECIFIED  
\*\* TD IS TRUNNION PIN DIAMETER

# TRUNNION MOUNTED CYLINDERS (Cont.)

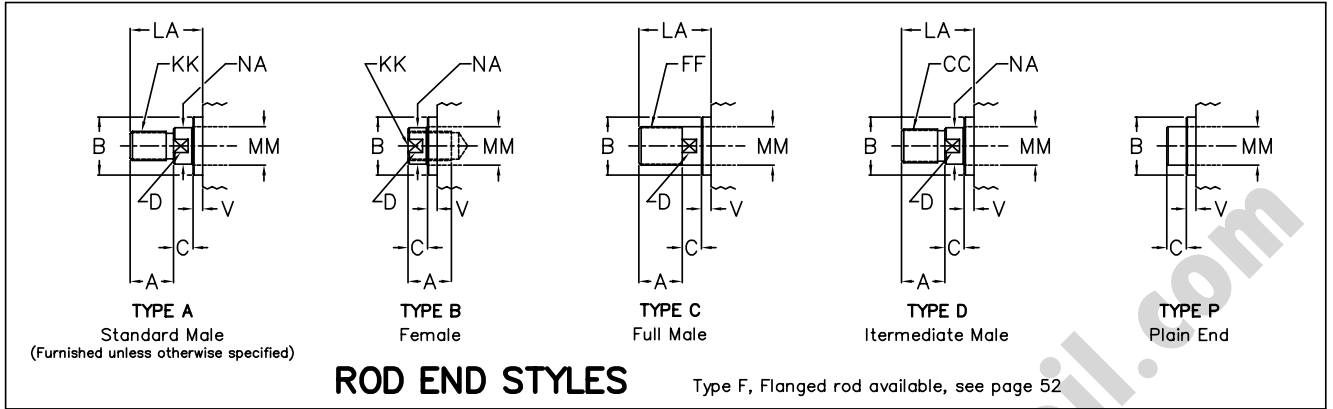

## DIMENSIONS AFFECTED BY ROD DIAMETER

BORE	ROD DIA. MM	THREAD SIZE			ROD AND PILOT DIMENSIONS								ENVELOPE DIMENSIONS					
		KK	CC	FF	A	B +.000 -.002	C	D	LA	NA	V	W	Y	XG	XI	XJ	ZB	
		STD													MIN.			ADD STROKE
1 1/2	5/8	7/16-20	1/2-20	5/8-18	3/4	1.124	3/8	1/2	1 3/8	9/16	1/4	5/8	1 15/16	1 3/4	3 1/8	4 1/8	4 7/8	
	1 *	3/4-16	7/8-14	1-14	1 1/8	1.499	1/2	7/8	2 1/8	15/16	1/2	1	2 5/16	2 1/8	3 1/2	4 1/2	5 1/4	
2	5/8	7/16-20	1/2-20	5/8-18	3/4	1.124	3/8	1/2	1 3/8	9/16	1/4	5/8	1 15/16	1 3/4	3 1/4	4 1/8	4 15/16	
	1	3/4-16	7/8-14	1-14	1 1/8	1.499	1/2	7/8	2 1/8	15/16	1/2	1	2 5/16	2 1/8	3 5/8	4 1/2	5 5/16	
	1 3/8 *	1-14	1 1/4-12	1 3/8-12	1 5/8	1.999	5/8	1 1/8	2 7/8	1 5/16	5/8	1 1/4	2 9/16	2 3/8	3 7/8	4 3/4	5 9/16	
2 1/2	5/8	7/16-20	1/2-20	5/8-18	3/4	1.124	3/8	1/2	1 3/8	9/16	1/4	5/8	1 15/16	1 3/4	3 1/4	4 1/4	5 1/16	
	1	3/4-16	7/8-14	1-14	1 1/8	1.499	1/2	7/8	2 1/8	15/16	1/2	1	2 5/16	2 1/8	3 5/8	4 5/8	5 7/16	
	1 3/8	1-14	1 1/4-12	1 3/8-12	1 5/8	1.999	5/8	1 1/8	2 7/8	1 5/16	5/8	1 1/4	2 9/16	2 3/8	3 7/8	4 7/8	5 11/16	
	1 3/4 *	1 1/4-12	1 1/2-12	1 3/4-12	2	2.374	3/4	1 1/2	3 1/2	1 11/16	3/4	1 1/2	2 13/16	2 5/8	4 1/8	5 1/8	5 15/16	
3 1/4	1	3/4-16	7/8-14	1-14	1 1/8	1.499	1/2	7/8	1 7/8	15/16	1/4	3/4	2 7/16	2 1/4	4 1/8	5	6	
	1 3/8	1-14	1 1/4-12	1 3/8-12	1 5/8	1.999	5/8	1 1/8	2 5/8	1 5/16	3/8	1	2 11/16	2 1/2	4 3/8	5 1/4	6 1/4	
	1 3/4	1 1/4-12	1 1/2-12	1 3/4-12	2	2.374	3/4	1 1/2	3 1/4	1 11/16	1/2	1 1/4	2 15/16	2 3/4	4 5/8	5 1/2	6 1/2	
	2 *	1 1/2-12	1 3/4-12	2-12	2 1/4	2.624	7/8	1 11/16	3 5/8	1 15/16	1/2	1 3/8	3 1/16	2 7/8	4 3/4	5 5/8	6 5/8	
4	1	3/4-16	7/8-14	1-14	1 1/8	1.499	1/2	7/8	1 7/8	15/16	1/4	3/4	2 7/16	2 1/4	4 1/8	5	6	
	1 3/8	1-14	1 1/4-12	1 3/8-12	1 5/8	1.999	5/8	1 1/8	2 5/8	1 5/16	3/8	1	2 11/16	2 1/2	4 3/8	5 1/4	6 1/4	
	1 3/4	1 1/4-12	1 1/2-12	1 3/4-12	2	2.374	3/4	1 1/2	3 1/4	1 11/16	1/2	1 1/4	2 15/16	2 3/4	4 5/8	5 1/2	6 1/2	
	2	1 1/2-12	1 3/4-12	2-12	2 1/4	2.624	7/8	1 11/16	3 5/8	1 15/16	1/2	1 3/8	3 1/16	2 7/8	4 3/4	5 5/8	6 5/8	
5	1	3/4-16	7/8-14	1-14	1 1/8	1.499	1/2	7/8	1 7/8	15/16	1/4	3/4	2 7/16	2 1/4	4 1/8	5 1/4	6 5/16	
	1 3/8	1-14	1 1/4-12	1 3/8-12	1 5/8	1.999	5/8	1 1/8	2 5/8	1 5/16	3/8	1	2 11/16	2 1/2	4 3/8	5 1/2	6 9/16	
	1 3/4	1 1/4-12	1 1/2-12	1 3/4-12	2	2.374	3/4	1 1/2	3 1/4	1 11/16	1/2	1 1/4	2 15/16	2 3/4	4 5/8	5 3/4	6 13/16	
	2	1 1/2-12	1 3/4-12	2-12	2 1/4	2.624	7/8	1 11/16	3 5/8	1 15/16	1/2	1 3/8	3 1/16	2 7/8	4 3/4	5 7/8	6 15/16	
6	1 3/8	1-14	1 1/4-12	1 3/8-12	1 5/8	1.999	5/8	1 1/8	2 1/2	1 5/16	1/4	7/8	2 13/16	2 5/8	4 7/8	5 7/8	7 1/16	
	1 3/4	1 1/4-12	1 1/2-12	1 3/4-12	2	2.374	3/4	1 1/2	3 1/8	1 11/16	3/8	1 1/8	3 1/16	2 7/8	5 1/8	6 1/8	7 5/16	
	2	1 1/2-12	1 3/4-12	2-12	2 1/4	2.624	7/8	1 11/16	3 1/2	1 15/16	3/8	1 1/4	3 3/16	3	5 1/4	6 1/4	7 7/16	
	2 1/2	1 7/8-12	2 1/4-12	2 1/2-12	3	3.124	1	2 1/16	4 1/2	2 3/8	1/2	1 1/2	3 7/16	3 1/4	5 1/2	6 1/2	7 11/16	

FIRST ROD SIZE SHOWN FOR EACH BORE SIZE IS STANDARD ROD

\* ROD END CUSHIONS AVAILABLE ONLY AS NON-ADJUSTABLE TYPE - CONSULT LEHIGH



# TIE ROD MOUNTED CYLINDERS

## 8" TO 12" BORE SERIES JHD AND LSSL AIR CYLINDERS

**AVAILABLE IN STANDARD CONSTRUCTION AND ALL STAINLESS STEEL DESIGN!**

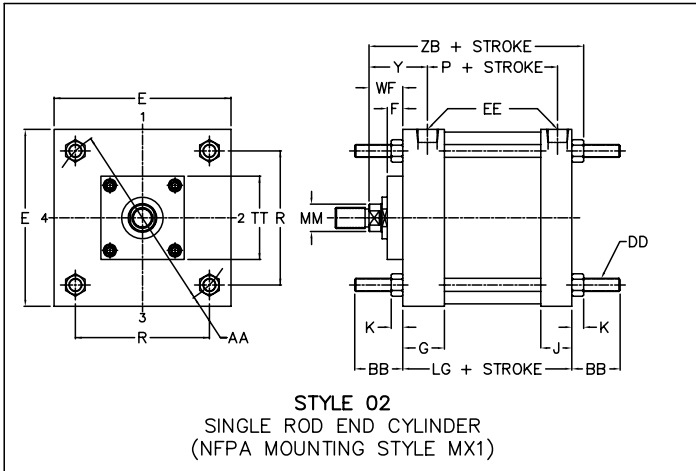

Standard Part location is Position 1.  
Standard Cushion location Position 2.

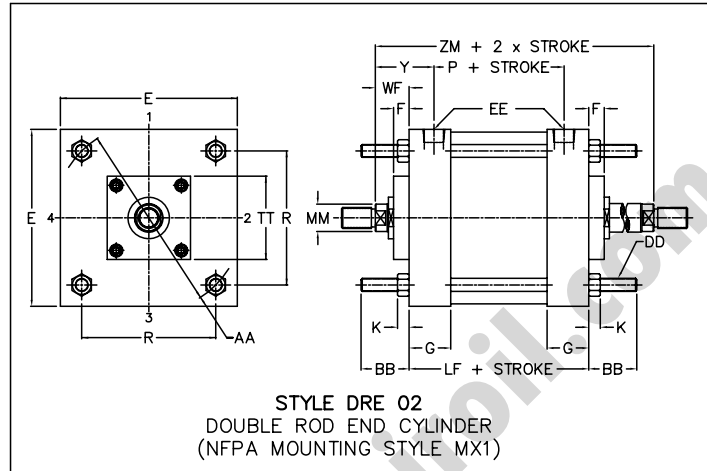

Standard Part location is Position 1.  
Standard Cushion location Position 2.

### MOUNTING DESCRIPTION

MOUNTING STYLE	NFPA MOUNTING STYLE	DESCRIPTION
01	MX0	NO TIE ROD EXTENSIONS
02	MX1	TIE RODS EXTENDED BOTH ENDS
03	MX2	TIE RODS EXTENDED CAP END
04	MX3	TIE RODS EXTENDED ROD END
DRE 01	MDX0	NO TIE ROD EXTENSIONS
DRE 02	MDX1	TIE RODS EXTENDED BOTH ENDS
DRE 03	MDX3	TIE RODS EXTENDED ONE END

For ROD END Styles and dimensional drawings, see p.23

### ENVELOPE AND MOUNTING DIMENSIONS NOT AFFECTED BY ROD DIAMETER

BORE	AA	BB	DD	E	EE (NPTF)	G	J	K	R	ADD STROKE		
										LF	LG	P
8	9.1	2 5/16	5/8-18	8 1/2	3/4	2	1 1/2	9/16	6.44	5 5/8	5 1/8	3 1/4
10	11.2	2 11/16	3/4-16	10 5/8	1	2 1/4	2	11/16	7.92	6 5/8	6 3/8	4 1/8
12	13.3	2 11/16	3/4-16	12 3/4	1	2 1/4	2	11/16	9.40	7 1/8	6 7/8	4 5/8

### DIMENSIONS AFFECTED BY ROD DIAMETER

BORE	ROD DIA. MM	THREAD SIZE			ROD AND PILOT DIMENSIONS								ENVELOPE DIMENSIONS				
		KK STD	CC	FF	A	B +0.000 -0.002	C	D	F	LA	NA	V	TT	WF	Y	ZB ADD STROKE	ZM ADD 2X STROKE
8	1 3/8	1-14	1 1/4-12	1 3/8-12	1 5/8	1.999	5/8	1 1/8	3/4	2 1/2	1 5/16	1/4	4	1 5/8	2 13/16	7 5/16	8 7/8
	1 3/4	1 1/4-12	1 1/2-12	1 3/4-12	2	2.374	3/4	1 1/2	3/4	3 1/8	1 11/16	3/8	4	1 7/8	3 1/16	7 9/16	9 3/8
	2	1 1/2-12	1 3/4-12	2-12	2 1/4	2.624	7/8	1 11/16	3/4	3 1/2	1 15/16	3/8	4	2	3 3/16	7 11/16	9 5/8
	2 1/2	1 7/8-12	2 1/4-12	2 1/2-12	3	3.124	1	2 1/16	3/4	4 1/2	2 3/8	1/2	4	2 1/4	3 7/16	7 15/16	10 1/8
10	1 3/4	1 1/4-12	1 1/2-12	1 3/4-12	2	2.374	3/4	1 1/2	3/4	3 1/8	1 11/16	3/8	4	1 7/8	3 1/8	8 15/16	10 3/8
	2	1 1/2-12	1 3/4-12	2-12	2 1/4	2.624	7/8	1 11/16	3/4	3 1/2	1 15/16	3/8	4	2	3 1/4	9 1/16	10 5/8
	2 1/2	1 7/8-12	2 1/4-12	2 1/2-12	3	3.124	1	2 1/16	3/4	4 1/2	2 3/8	1/2	4	2 1/4	3 1/2	9 5/16	11 1/8
	3	2 1/4-12	2 3/4-12	3-12	3 1/2	3.749	1	2 5/8	3/4	5	2 7/8	1/2	5 1/2	2 1/4	3 1/2	9 5/16	11 1/8
12	2	1 1/2-12	1 3/4-12	2-12	2 1/4	2.624	7/8	1 11/16	3/4	3 1/2	1 15/16	3/8	4	2	3 1/4	9 9/16	11 1/8
	2 1/2	1 7/8-12	2 1/4-12	2 1/2-12	3	3.124	1	2 1/16	3/4	4 1/2	2 3/8	1/2	4	2 1/4	3 1/2	9 13/16	11 5/8
	3	2 1/4-12	2 3/4-12	3-12	3 1/2	3.749	1	2 5/8	3/4	5	2 7/8	1/2	5 1/2	2 1/4	3 1/2	9 13/16	11 5/8
	3 1/2	2 1/2-12	3 1/4-12	3 1/2-12	3 1/2	4.249	1	3	3/4	5	3 3/8	1/2	5 1/2	2 1/4	3 1/2	9 13/16	11 5/8

FIRST ROD SIZE SHOWN FOR EACH BORE SIZE IS STANDARD ROD



# FOOT AND FLUSH MOUNTED CYLINDERS

## 8" TO 12" BORE SERIES JHD AND LSSL AIR CYLINDERS

AVAILABLE IN STANDARD CONSTRUCTION AND ALL STAINLESS STEEL DESIGN!

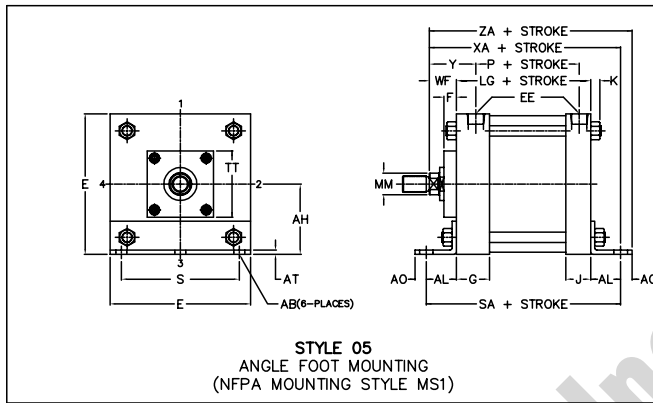
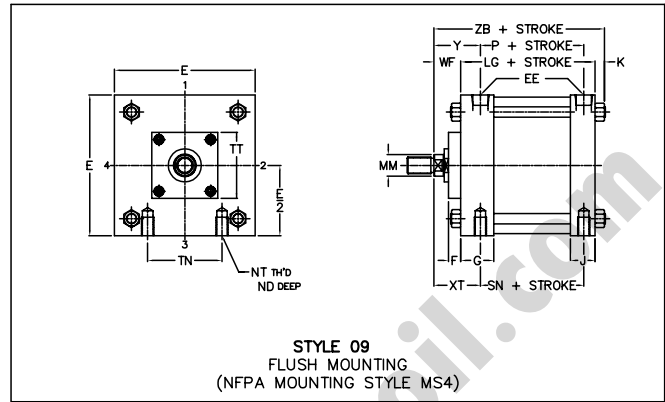
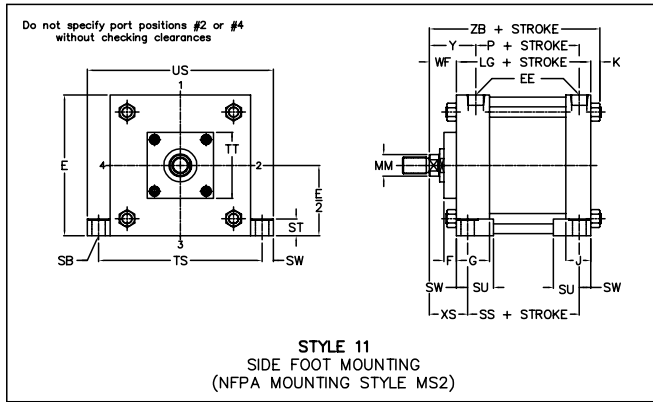

For ROD END Styles and dimensional drawings, see p.23

### ENVELOPE AND MOUNTING DIMENSIONS NOT AFFECTED BY ROD DIAMETER

BORE	AB	AH	AL	AO	AT	E	EE (NPTF)	G	J	K	ND	NT	S	SB	ST	SU	SW	TN	TS	US	ADD STROKE				
																					LG	P	SA	SN	SS
8	13/16	4 1/4	1 13/16	11/16	1/4	8 1/2	3/4	2	1 1/2	9/16	1 1/8	3/4-10	7 1/8	13/16	1	19/16	11/16	4 1/2	9/78	11 1/4	5 1/8	3 1/4	8 3/4	3 1/4	3 3/4
10	1 1/16	5 5/16	2 1/8	7/8	1/4	10 5/8	1	2 1/4	2	11/16	1 1/2	1-8	8 7/8	1 1/16	1 1/4	2	7/8	5 1/2	12 3/8	14 1/8	6 3/8	4 1/8	10 5/8	4 1/8	4 5/8
12	1 1/16	6 3/8	2 1/8	7/8	3/8	12 3/4	1	2 1/4	2	11/16	1 1/2	1-8	11	1 1/16	1 1/4	2	7/8	7 1/4	14 1/2	16 1/4	6 7/8	4 5/8	11 1/8	4 5/8	5 1/8

### DIMENSIONS AFFECTED BY ROD DIAMETER

BORE	ROD DIA. MM	THREAD SIZE			ROD AND PILOT DIMENSIONS								ENVELOPE DIMENSIONS							
		KK STD	CC	FF	A	B +0.000 -0.002	C	D	F	LA	NA	V	TT	WF	Y	XS	XT	XA	ZA	ZB
																		ADD STROKE		
8	1 3/8	1-14	1 1/4-12	1 3/8-12	15/8	1.999	5/8	1 1/8	3/4	2 1/2	15/16	1/4	4	1 5/8	2 13/16	2 5/16	2 13/16	8 9/16	9 1/4	7 5/16
	1 3/4	1 1/4-12	1 1/2-12	1 3/4-12	2	2.374	3/4	1 1/2	3/4	3 1/8	1 11/16	3/8	4	1 7/8	3 1/16	2 9/16	3 1/16	8 13/16	9 1/2	7 9/16
	2	1 1/2-12	1 3/4-12	2-12	2 1/4	2.624	7/8	1 11/16	3/4	3 1/2	1 15/16	3/8	4	2	3 3/16	2 11/16	3 3/16	8 15/16	9 5/8	7 11/16
	2 1/2	1 7/8-12	2 1/4-12	2 1/2-12	3	3.124	1	2 1/16	3/4	4 1/2	2 3/8	1/2	4	2 1/4	3 7/16	2 15/16	3 7/16	9 3/16	9 7/8	7 15/16
10	1 3/4	1 1/4-12	1 1/2-12	1 3/4-12	2	2.374	3/4	1 1/2	3/4	3 1/8	1 11/16	3/8	4	1 7/8	3 1/8	2 3/4	3 1/8	10 3/8	11 1/4	8 15/16
	2	1 1/2-12	1 3/4-12	2-12	2 1/4	2.624	7/8	1 11/16	3/4	3 1/2	1 15/16	3/8	4	2	3 1/4	2 7/8	3 1/4	10 1/2	11 3/8	9 1/16
	2 1/2	1 7/8-12	2 1/4-12	2 1/2-12	3	3.124	1	2 1/16	3/4	4 1/2	2 3/8	1/2	4	2 1/4	3 1/2	3 1/8	3 1/2	10 3/4	11 5/8	9 5/16
	3	2 1/4-12	2 3/4-12	3-12	3 1/2	3.749	1	2 5/8	3/4	5	2 7/8	1/2	5 1/2	2 1/4	3 1/2	3 1/8	3 1/2	10 3/4	11 5/8	9 5/16
12	2	1 1/2-12	1 3/4-12	2-12	2 1/4	2.624	7/8	1 11/16	3/4	3 1/2	1 15/16	3/8	4	2	3 1/4	2 7/8	3 1/4	11	11 7/8	9 9/16
	2 1/2	1 7/8-12	2 1/4-12	2 1/2-12	3	3.124	1	2 1/16	3/4	4 1/2	2 3/8	1/2	4	2 1/4	3 1/2	3 1/8	3 1/2	11 1/4	12 1/8	9 13/16
	3	2 1/4-12	2 3/4-12	3-12	3 1/2	3.749	1	2 5/8	3/4	5	2 7/8	1/2	5 1/2	2 1/4	3 1/2	3 1/8	3 1/2	11 1/4	12 1/8	9 13/16
	3 1/2	2 1/2-12	3 1/4-12	3 1/2-12	3 1/2	4.249	1	3	3/4	5	3 3/8	1/2	5 1/2	2 1/4	3 1/2	3 1/8	3 1/2	11 1/4	12 1/8	9 13/16

FIRST ROD SIZE SHOWN FOR EACH BORE SIZE IS STANDARD ROD



# CLEVIS AND SPHERICAL BEARING MOUNTED CYLINDERS

## 8" TO 12" BORE SERIES JHD AND LSSL AIR CYLINDERS

AVAILABLE IN STANDARD CONSTRUCTION AND ALL STAINLESS STEEL DESIGN!

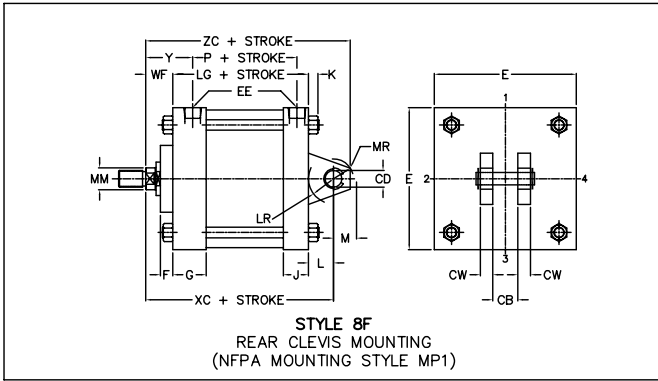

Standard Port location is Position 1.  
Standard Cushion Location is Position 2.

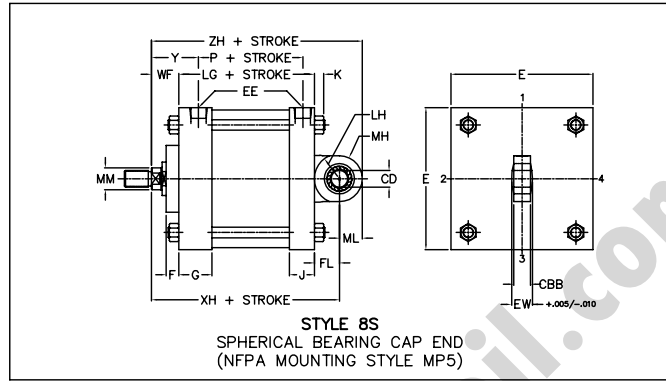

Standard Port location is Position 1.  
Standard Cushion Location is Position 2.

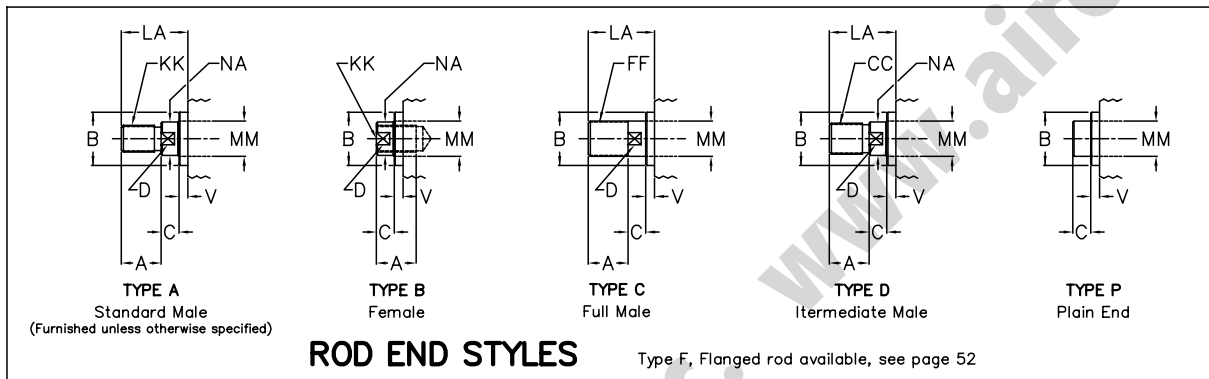

### ENVELOPE AND MOUNTING DIMENSIONS NOT AFFECTED BY ROD DIAMETER

BORE	CB	CBB	CD * +.000 -.002	CW	E	EE (NPTF)	EW	FL	G	J	K	L	LR	M	MH	ML	MR	ADD STROKE	
																		LG	P
8	1 1/2	3/4	1.000	3/4	8 1/2	3/4	7/8	1 1/2	2	1 1/2	9/16	1 1/2	1 1/4	1	1 1/2	1 1/2	1 3/16	5 1/8	3 1/4
10	2	1 1/32	1.375	1	10 5/8	1	1 3/16	2 1/8	2 1/4	2	11/16	2 1/8	1 3/4	1 3/8	2 1/4	2 1/4	1 5/8	6 3/8	4 1/8
12	2 1/2	1 5/16	1.750	1 1/4	12 3/4	1	1 17/32	2 1/4	2 1/4	2	11/16	2 1/4	2	1 3/4	2 3/4	2 3/4	2 1/8	6 7/8	4 5/8

\* CD IS PIN DIAMETER

### DIMENSIONS AFFECTED BY ROD DIAMETER

BORE	ROD DIA. MM	THREAD SIZE			ROD AND PILOT DIMENSIONS								ENVELOPE DIMENSIONS							
		KK STD	CC	FF	A	B +.000 -.002	C	D	F	LA	NA	V	TT	WF	Y	XC	XH	ZC	ZH	
																				ADD STROKE
8	1 3/8	1-14	1 1/4-12	1 3/8-12	1 5/8	1.999	5/8	1 1/8	3/4	2 1/2	1 5/16	1/4	4	1 5/8	2 13/16	8 1/4	8 1/4	9 1/4	9 3/4	
	1 3/4	1 1/4-12	1 1/2-12	1 3/4-12	2	2.374	3/4	1 1/2	3/4	3 1/8	1 11/16	3/8	4	1 7/8	3 1/16	8 1/2	8 1/2	9 1/2	10	
	2	1 1/2-12	1 3/4-12	2-12	2 1/4	2.624	7/8	1 11/16	3/4	3 1/2	1 15/16	3/8	4	2	3 3/16	8 5/8	8 5/8	9 5/8	10 1/8	
	2 1/2	1 7/8-12	2 1/4-12	2 1/2-12	3	3.124	1	2 1/16	3/4	4 1/2	2 3/8	1/2	4	2 1/4	3 7/16	8 7/8	8 7/8	9 7/8	10 3/8	
10	1 3/4	1 1/4-12	1 1/2-12	1 3/4-12	2	2.374	3/4	1 1/2	3/4	3 1/8	1 11/16	3/8	4	1 7/8	3 1/8	10 3/8	10 3/8	11 3/4	12 5/8	
	2	1 1/2-12	1 3/4-12	2-12	2 1/4	2.624	7/8	1 11/16	3/4	3 1/2	1 15/16	3/8	4	2	3 1/4	10 1/2	10 1/2	11 7/8	12 3/4	
	2 1/2	1 7/8-12	2 1/4-12	2 1/2-12	3	3.124	1	2 1/16	3/4	4 1/2	2 3/8	1/2	4	2 1/4	3 1/2	10 3/4	10 3/4	12 1/8	13	
12	3	2 1/4-12	2 3/4-12	3-12	3 1/2	3.749	1	2 5/8	3/4	5	2 7/8	1/2	5 1/2	2 1/4	3 1/2	10 3/4	10 3/4	12 1/8	13	
	2	1 1/2-12	1 3/4-12	2-12	2 1/4	2.624	7/8	1 11/16	3/4	3 1/2	1 15/16	3/8	4	2	3 1/4	11 1/8	11 1/8	12 7/8	13 7/8	
	2 1/2	1 7/8-12	2 1/4-12	2 1/2-12	3	3.124	1	2 1/16	3/4	4 1/2	2 3/8	1/2	4	2 1/4	3 1/2	11 3/8	11 3/8	13 1/8	14 1/8	
	3	2 1/4-12	2 3/4-12	3-12	3 1/2	3.749	1	2 5/8	3/4	5	2 7/8	1/2	5 1/2	2 1/4	3 1/2	11 3/8	11 3/8	13 1/8	14 1/8	
12	3 1/2	2 1/2-12	3 1/4-12	3 1/2-12	3 1/2	4.249	1	3	3/4	5	3 3/8	1/2	5 1/2	2 1/4	3 1/2	11 3/8	11 3/8	13 1/8	14 1/8	

FIRST ROD SIZE SHOWN FOR EACH BORE SIZE IS STANDARD ROD

Notes: Clevis Pin comes standard with 8F and 8D Mounts

Type "B" rod end style is preferred on the 8S style mount cylinder due to the availability of mounting accessories.

See pages 54-57 for mounting accessories



# FLANGE MOUNTED CYLINDERS

## 8" TO 12" BORE SERIES JHD AND LSSL AIR CYLINDERS

**AVAILABLE IN STANDARD CONSTRUCTION AND ALL STAINLESS STEEL DESIGN!**

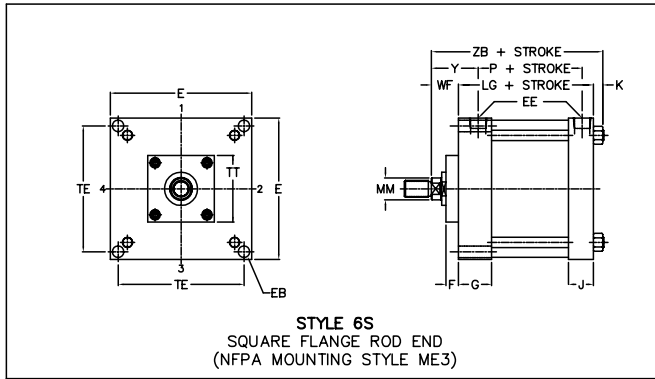

Standard Port location is Position 1.  
Standard Cushion location is Position 2.

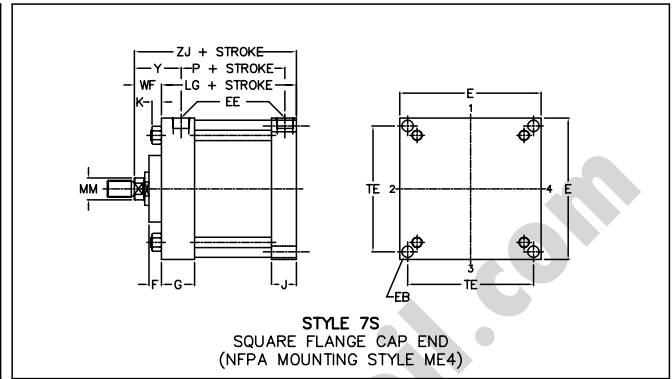

Standard Port location is Position 1.  
Standard Cushion location is Position 2.

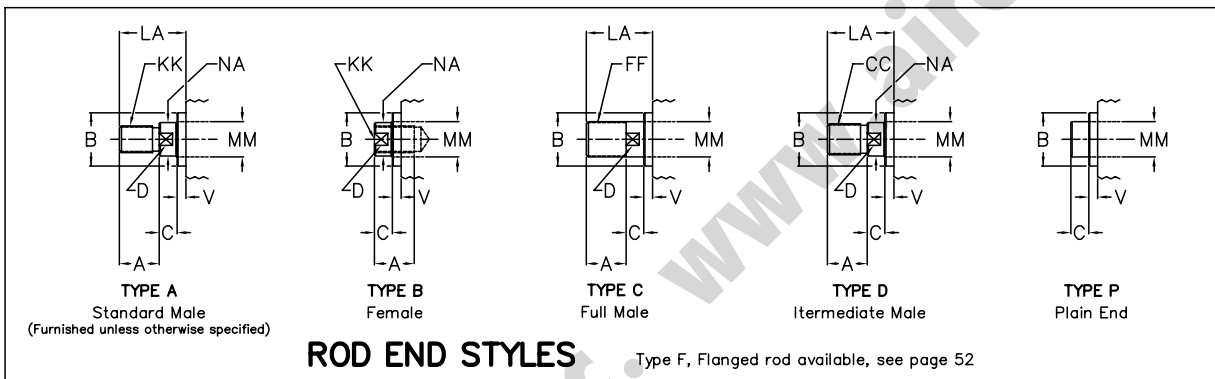

### ENVELOPE AND MOUNTING DIMENSIONS NOT AFFECTED BY ROD DIAMETER

BORE	E	EE (NPTF)	EB	G	J	K	TE	P	
								LG	ADD STROKE
8	8 1/2	3/4	11/16	2	1 1/2	9/16	7.57	5 1/8	3 1/4
10	10 5/8	1	13/16	2 1/4	2	11/16	9.40	6 3/8	4 1/8
12	12 3/4	1	13/16	2 1/4	2	11/16	11.10	6 7/8	4 5/8

### DIMENSIONS AFFECTED BY ROD DIAMETER

BORE	ROD DIA. MM	THREAD SIZE			ROD AND PILOT DIMENSIONS								ENVELOPE DIMENSIONS				
		KK STD	CC	FF	A	B +0.000 -0.002	C	D	F	LA	NA	V	TT	WF	Y	ZB	ZJ
8	1 3/8	1-14	1 1/4-12	1 3/8-12	1 5/8	1.999	5/8	1 1/8	3/4	2 1/2	1 5/16	1/4	4	1 5/8	2 13/16	7 5/16	6 3/4
	1 3/4	1 1/4-12	1 1/2-12	1 3/4-12	2	2.374	3/4	1 1/2	3/4	3 1/8	1 11/16	3/8	4	1 7/8	3 1/16	7 9/16	7
	2	1 1/2-12	1 3/4-12	2-12	2 1/4	2.624	7/8	1 11/16	3/4	3 1/2	1 15/16	3/8	4	2	3 3/16	7 11/16	7 1/8
	2 1/2	1 7/8-12	2 1/4-12	2 1/2-12	3	3.124	1	2 1/16	3/4	4 1/2	2 3/8	1/2	4	2 1/4	3 7/16	7 15/16	7 3/8
10	1 3/4	1 1/4-12	1 1/2-12	1 3/4-12	2	2.374	3/4	1 1/2	3/4	3 1/8	1 11/16	3/8	4	1 7/8	3 1/8	8 15/16	8 1/4
	2	1 1/2-12	1 3/4-12	2-12	2 1/4	2.624	7/8	1 11/16	3/4	3 1/2	1 15/16	3/8	4	2	3 1/4	9 1/16	8 3/8
	2 1/2	1 7/8-12	2 1/4-12	2 1/2-12	3	3.124	1	2 1/16	3/4	4 1/2	2 3/8	1/2	4	2 1/4	3 1/2	9 5/16	8 5/8
	3	2 1/4-12	2 3/4-12	3-12	3 1/2	3.749	1	2 5/8	3/4	5	2 7/8	1/2	5 1/2	2 1/4	3 1/2	9 5/16	8 5/8
12	2	1 1/2-12	1 3/4-12	2-12	2 1/4	2.624	7/8	1 11/16	3/4	3 1/2	1 15/16	3/8	4	2	3 1/4	9 9/16	8 7/8
	2 1/2	1 7/8-12	2 1/4-12	2 1/2-12	3	3.124	1	2 1/16	3/4	4 1/2	2 3/8	1/2	4	2 1/4	3 1/2	9 13/16	9 1/8
	3	2 1/4-12	2 3/4-12	3-12	3 1/2	3.749	1	2 5/8	3/4	5	2 7/8	1/2	5 1/2	2 1/4	3 1/2	9 13/16	9 1/8
	3 1/2	2 1/2-12	3 1/4-12	3 1/2-12	3 1/2	4.249	1	3	3/4	5	3 3/8	1/2	5 1/2	2 1/4	3 1/2	9 13/16	9 1/8

FIRST ROD SIZE SHOWN FOR EACH BORE SIZE IS STANDARD ROD





# TRUNNION MOUNTED CYLINDERS

## 8" TO 12" BORE SERIES JHD AND LSSL AIR CYLINDERS

**AVAILABLE IN STANDARD CONSTRUCTION AND ALL STAINLESS STEEL DESIGN!**

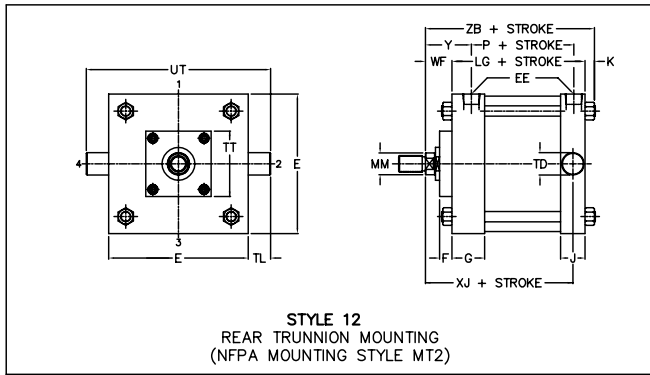

Standard Port location is Position 1. Standard Cushion location is Position 2 Rod End, and Position 3 Cap End.

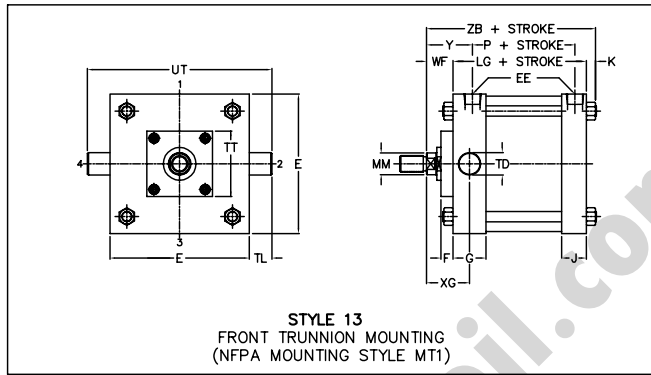

Standard Port location is Position 1. Standard Cushion location is Position 3 Rod End, and Position 2 Cap End.

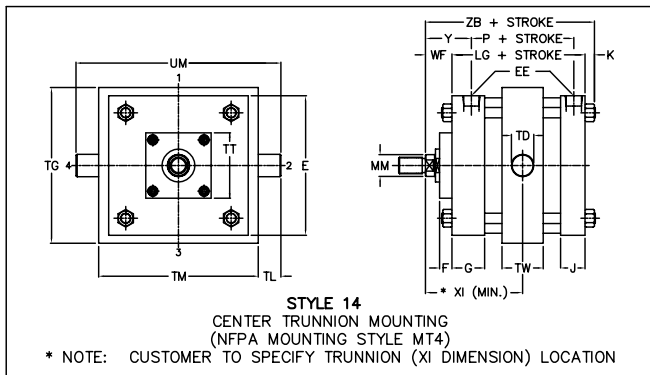

Standard Port location is Position 1.  
Standard Cushion location is Position 2.

For ROD END Styles and dimensional drawings, see p.30

### ENVELOPE AND MOUNTING DIMENSIONS NOT AFFECTED BY ROD DIAMETER

BORE	E	EE (NPTF)	G	J	K	TD * +0.000 -0.001	TG	TL	TM	TW	UM	UT	ADD STROKE	
													LG	P
8	8 1/2	3/4	2	1 1/2	9/16	1.375	9 1/2	1 3/8	9 3/4	2 1/2	12 1/2	11 1/4	5 1/8	3 1/4
10	10 5/8	1	2 1/4	2	11/16	1.750	11 3/4	1 3/4	12	3	15 1/2	14 1/8	6 3/8	4 1/8
12	12 3/4	1	2 1/4	2	11/16	1.750	13 3/4	1 3/4	14	3	17 1/2	16 1/4	6 7/8	4 5/8

\* TD IS TRUNNION PIN DIAMETER

### DIMENSIONS AFFECTED BY ROD DIAMETER

BORE	ROD DIA. MM	THREAD SIZE			ROD AND PILOT DIMENSIONS								ENVELOPE DIMENSIONS						
		KK STD	CC	FF	A	B +0.000 -0.002	C	D	F	LA	NA	V	TT	WF	Y	XG	XI MIN	XJ	ZB
8	1 3/8	1-14	1 1/4-12	1 3/8-12	1 5/8	1.999	5/8	1 1/8	3/4	2 1/2	1 5/16	1/4	4	1 5/8	2 13/16	2 5/8	4 7/8	6	7 5/16
	1 3/4	1 1/4-12	1 1/2-12	1 3/4-12	2	2.374	3/4	1 1/2	3/4	3 1/8	1 11/16	3/8	4	1 7/8	3 1/16	2 7/8	5 1/8	6 1/4	7 9/16
	2	1 1/2-12	1 3/4-12	2-12	2 1/4	2.624	7/8	1 11/16	3/4	3 1/2	1 15/16	3/8	4	2	3 3/16	3	5 1/4	6 3/8	7 11/16
	2 1/2	1 7/8-12	2 1/4-12	2 1/2-12	3	3.124	1	2 1/16	3/4	4 1/2	2 3/8	1/2	4	2 1/4	3 7/16	3 1/4	5 1/2	6 5/8	7 15/16
10	1 3/4	1 1/4-12	1 1/2-12	1 3/4-12	2	2.374	3/4	1 1/2	3/4	3 1/8	1 11/16	3/8	4	1 7/8	3 1/8	3	5 5/8	7 1/4	8 15/16
	2	1 1/2-12	1 3/4-12	2-12	2 1/4	2.624	7/8	1 11/16	3/4	3 1/2	1 15/16	3/8	4	2	3 1/4	3 1/8	5 3/4	7 3/8	9 1/16
	2 1/2	1 7/8-12	2 1/4-12	2 1/2-12	3	3.124	1	2 1/16	3/4	4 1/2	2 3/8	1/2	4	2 1/4	3 1/2	3 3/8	6	7 5/8	9 5/16
	3	2 1/4-12	2 3/4-12	3-12	3 1/2	3.749	1	2 5/8	3/4	5	2 7/8	1/2	5 1/2	2 1/4	3 1/2	3 3/8	6	7 5/8	9 5/16
12	2	1 1/2-12	1 3/4-12	2-12	2 1/4	2.624	7/8	1 11/16	3/4	3 1/2	1 15/16	3/8	4	2	3 1/4	3 1/8	5 3/4	7 7/8	9 9/16
	2 1/2	1 7/8-12	2 1/4-12	2 1/2-12	3	3.124	1	2 1/16	3/4	4 1/2	2 3/8	1/2	4	2 1/4	3 1/2	3 3/8	6	8 1/8	9 13/16
	3	2 1/4-12	2 3/4-12	3-12	3 1/2	3.749	1	2 5/8	3/4	5	2 7/8	1/2	5 1/2	2 1/4	3 1/2	3 3/8	6	8 1/8	9 13/16
	3 1/2	2 1/2-12	3 1/4-12	3 1/2-12	3 1/2	4.249	1	3	3/4	5	3 3/8	1/2	5 1/2	2 1/4	3 1/2	3 3/8	6	8 1/8	9 13/16

FIRST ROD SIZE SHOWN FOR EACH BORE SIZE IS STANDARD ROD



# TIE ROD MOUNTED CYLINDERS

## 14" TO 20" BORE SERIES JHD AND LSSL AIR CYLINDERS

**AVAILABLE IN STANDARD CONSTRUCTION AND ALL STAINLESS STEEL DESIGN!**

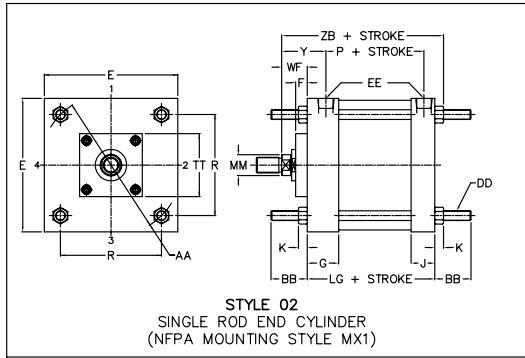

Standard Port location is Position 1.  
Standard Cushion location Position 2.

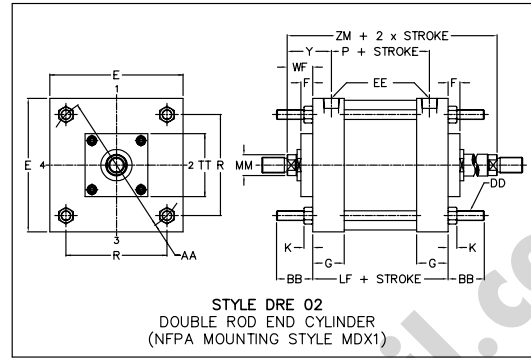

Standard Port location is Position 1.  
Standard Cushion location Position 2.

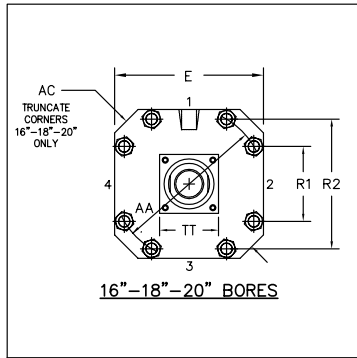

### MOUNTING DESCRIPTION

MOUNTING STYLE	NFPA MOUNTING STYLE	DESCRIPTION
01	MX0	NO TIE ROD EXTENSIONS
02	MX1	TIE RODS EXTENDED BOTH ENDS
03	MX2	TIE RODS EXTENDED CAP END
04	MX3	TIE RODS EXTENDED ROD END
DRE 01	MDX0	NO TIE ROD EXTENSIONS
DRE 02	MDX1	TIE RODS EXTENDED BOTH ENDS
DRE 03	MDX3	TIE RODS EXTENDED ONE END

**NOTE: THE 14" BORE USES FOUR (4) TIE RODS.**  
**BORE SIZES 16"-18"-20" USE EIGHT (8) TIE RODS.**

For ROD END Styles and dimensional drawings, see p.30

### ENVELOPE AND MOUNTING DIMENSIONS NOT AFFECTED BY ROD DIAMETER

BORE	NUM. TIE RODS	AA	AC	BB	DD	E	EE (NPTF)	G	J	K	R	R1	R2	ADD STROKE		
														LF	LG	P
14	4	15.40	-	3 3/16	7/8-14	14 3/4	1 1/4	2 3/4	2 1/4	3/4	10.90	-	-	8 5/8	8 1/8	5 1/2
16	8	18.19	20 1/2	3 5/8	1-14	17 1/2	1 1/4	2 3/4	2 3/4	7/8	-	10.25	15.02	8 7/8	8 7/8	5 3/4
18	8	20.19	22 1/2	4 1/16	1-14	19 1/2	1 1/2	3 1/4	3 1/4	7/8	-	11.50	16.59	9 7/8	9 7/8	6 3/8
20	8	22.31	25	4 3/8	1 1/8-12	21 1/2	2	3 3/4	3 3/4	1	-	12.62	18.40	11 3/8	11 3/8	7 3/8

### DIMENSIONS AFFECTED BY ROD DIAMETER

BORE	ROD DIA. MM	THREAD SIZE			ROD AND PILOT DIMENSIONS								ENVELOPE DIMENSIONS				
		KK STD	CC	FF	A	B +.000 - .002	C	D	F	LA	NA	V	TT	WF	Y	ZB ADD STROKE	ZM ADD 2X STROKE
14	2 1/2	1 7/8-12	2 1/4-12	2 1/2-12	3	3.124	1	2 1/16	3/4	4 1/2	2 3/8	1/2	4	2 1/4	3 13/16	11 1/8	13 1/8
	3	2 1/4-12	2 3/4-12	3-12	3 1/2	3.749	1	2 5/8	3/4	5	2 7/8	1/2	5 1/2	2 1/4	3 13/16	11 1/8	13 1/8
	3 1/2	2 1/2-12	3 1/4-12	3 1/2-12	3 1/2	4.249	1	3	3/4	5	3 3/8	1/2	5 1/2	2 1/4	3 13/16	11 1/8	13 1/8
16	4	3-12	3 3/4-12	4-12	4	4.749	1	3 3/8	1	5 1/4	3 7/8	1/4	7 1/2	2 1/4	3 13/16	11 1/8	13 1/8
	3	2 1/4-12	2 3/4-12	3-12	3 1/2	3.749	1	2 5/8	3/4	5	2 7/8	1/2	5 1/2	2 1/4	3 13/16	12	13 3/8
	3 1/2	2 1/2-12	3 1/4-12	3 1/2-12	3 1/2	4.249	1	3	3/4	5	3 3/8	1/2	5 1/2	2 1/4	3 13/16	12	13 3/8
18	4	3-12	3 3/4-12	4-12	4	4.749	1	3 3/8	1	5 1/4	3 7/8	1/4	7 1/2	2 1/4	3 13/16	12	13 3/8
	5	3 1/2-12	4 3/4-12	5-12	5	5.749	1	4 1/4	1	6 1/4	4 7/8	1/4	8 1/2	2 1/4	3 13/16	12	13 3/8
	3 1/2	2 1/2-12	3 1/4-12	3 1/2-12	3 1/2	4.249	1	3	3/4	5	3 3/8	1/2	5 1/2	2 1/4	4	13	14 3/8
20	4	3-12	3 3/4-12	4-12	4	4.749	1	3 3/8	1	5 1/4	3 7/8	1/4	7 1/2	2 1/4	4	13	14 3/8
	5	3 1/2-12	4 3/4-12	5-12	5	5.749	1	4 1/4	1	6 1/4	4 7/8	1/4	8 1/2	2 1/4	4	13	14 3/8
	5 1/2	4-12	5 1/4-12	5 1/2-12	5 1/2	6.249	1	4 5/8	1	6 3/4	5 3/8	1/4	9 1/2	2 1/4	4	13	14 3/8
	3 1/2	2 1/2-12	3 1/4-12	3 1/2-12	3 1/2	4.249	1	3	3/4	5	3 3/8	1/2	5 1/2	2 1/4	4 1/4	14 5/8	15 7/8
20	4	3-12	3 3/4-12	4-12	4	4.749	1	3 3/8	1	5 1/4	3 7/8	1/4	7 1/2	2 1/4	4 1/4	14 5/8	15 7/8
	5	3 1/2-12	4 3/4-12	5-12	5	5.749	1	4 1/4	1	6 1/4	4 7/8	1/4	8 1/2	2 1/4	4 1/4	14 5/8	15 7/8
20	5 1/2	4-12	5 1/4-12	5 1/2-12	5 1/2	6.249	1	4 5/8	1	6 3/4	5 3/8	1/4	9 1/2	2 1/4	4 1/4	14 5/8	15 7/8

NPT PORTS FURNISHED UNLESS OTHERWISE SPECIFIED  
FIRST ROD SIZE SHOWN FOR EACH BORE SIZE IS STANDARD ROD



# FOOT AND FLUSH MOUNTED CYLINDERS

## 14" TO 20" BORE SERIES JHD AND LSSL AIR CYLINDERS

**AVAILABLE IN STANDARD CONSTRUCTION AND ALL STAINLESS STEEL DESIGN!**

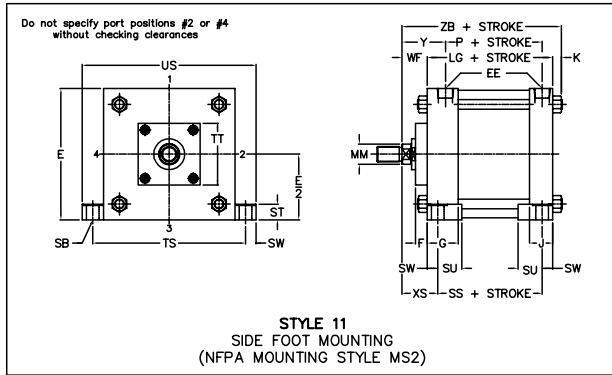

Standard Port location is Position 1.  
Standard Cushion location is Position 2.

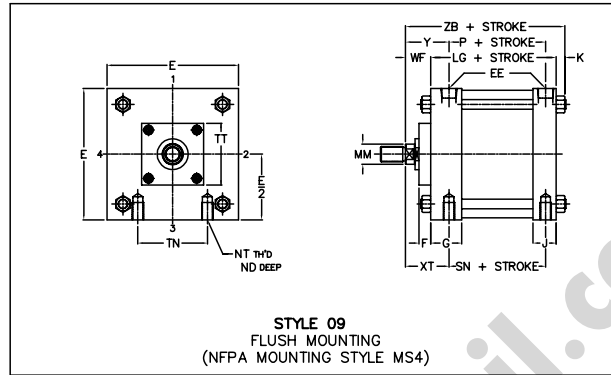

Standard Port location is Position 1.  
Standard Cushion location is Position 2.

NOTE: THE 14" BORE USES FOUR (4) TIE RODS. BORE SIZES 16"-18"-20" USE EIGHT (8) TIE RODS. (SEE ILLUSTRATIONS ON P29)

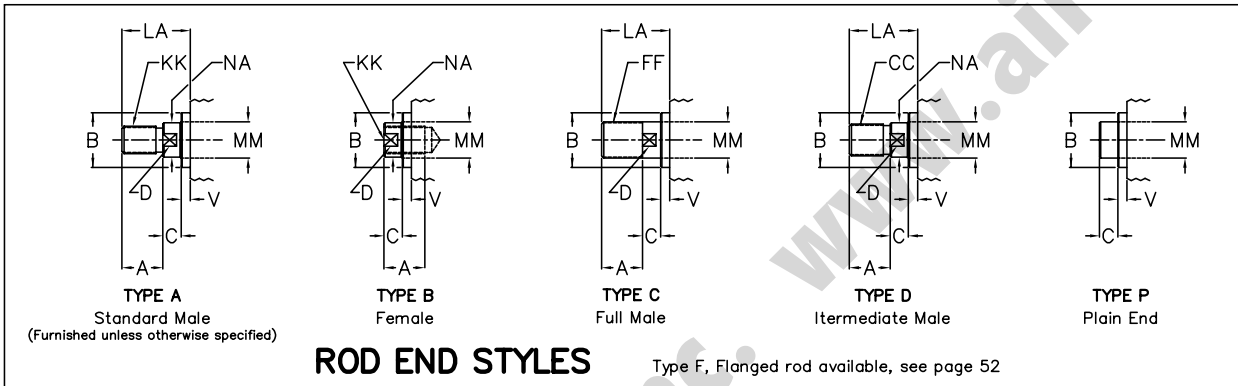

### ENVELOPE AND MOUNTING DIMENSIONS NOT AFFECTED BY ROD DIAMETER

BORE	NUM. TIE RODS	E	EE (NPTF)	G	J	K	ND	NT	SB	ST	SU	SW	TN	TS	US	LG	P	SN	SS
14	4	14 3/4	1 1/4	2 3/4	2 1/4	3/4	1 7/8	1 1/4-7	1 5/16	1 1/2	2 1/2	1 1/8	8 3/8	17	19 1/4	8 1/8	5 1/2	5 1/2	5 7/8
16	8	17 1/2	1 1/4	2 3/4	2 3/4	7/8	3	1 3/4-12	1 13/16	2	3 1/2	1 3/4	7	21	24 1/2	8 7/8	5 3/4	6 1/8	5 3/8
18	8	19 1/2	1 1/2	3 1/4	3 1/4	7/8	3 1/4	2-12	2 1/16	2 1/2	3 1/2	2	8	23 1/2	27 1/2	9 7/8	6 3/8	6 5/8	5 7/8
20	8	21 1/2	2	3 3/4	3 3/4	1	3 3/4	2 1/4-12	2 5/16	3	3 5/8	2 3/8	8 1/2	26 1/4	31	11 3/8	7 3/8	7 3/8	6 5/8

### DIMENSIONS AFFECTED BY ROD DIAMETER

BORE	ROD DIA. MM	THREAD SIZE			ROD AND PILOT DIMENSIONS							ENVELOPE DIMENSIONS						
		KK STD	CC	FF	A	B +.000 -002	C	D	F	LA	NA	V	TT	WF	Y	XS	XT	ZB ADD STROKE
14	2 1/2	1 7/8-12	2 1/4-12	2 1/2-12	3	3.124	1	2 1/16	3/4	4 1/2	2 3/8	1/2	4	2 1/4	3 13/16	3 3/8	3 13/16	11 1/8
	3	2 1/4-12	2 3/4-12	3-12	3 1/2	3.749	1	2 5/8	3/4	5	2 7/8	1/2	5 1/2	2 1/4	3 13/16	3 3/8	3 13/16	11 1/8
	3 1/2	2 1/2-12	3 1/4-12	3 1/2-12	3 1/2	4.249	1	3	3/4	5	3 3/8	1/2	5 1/2	2 1/4	3 13/16	3 3/8	3 13/16	11 1/8
	4	3-12	3 3/4-12	4-12	4	4.749	1	3 3/8	1	5 1/4	3 7/8	1/4	7 1/2	2 1/4	3 13/16	3 3/8	3 13/16	11 1/8
16	3	2 1/4-12	2 3/4-12	3-12	3 1/2	3.749	1	2 5/8	3/4	5	2 7/8	1/2	5 1/2	2 1/4	3 13/16	4	3 5/8	12
	3 1/2	2 1/2-12	3 1/4-12	3 1/2-12	3 1/2	4.249	1	3	3/4	5	3 3/8	1/2	5 1/2	2 1/4	3 13/16	4	3 5/8	12
	4	3-12	3 3/4-12	4-12	4	4.749	1	3 3/8	1	5 1/4	3 7/8	1/4	7 1/2	2 1/4	3 13/16	4	3 5/8	12
	5	3 1/2-12	4 3/4-12	5-12	5	5.749	1	4 1/4	1	6 1/4	4 7/8	1/4	8 1/2	2 1/4	3 13/16	4	3 5/8	12
18	3 1/2	2 1/2-12	3 1/4-12	3 1/2-12	3 1/2	4.249	1	3	3/4	5	3 3/8	1/2	5 1/2	2 1/4	4	4 1/4	3 7/8	13
	4	3-12	3 3/4-12	4-12	4	4.749	1	3 3/8	1	5 1/4	3 7/8	1/4	7 1/2	2 1/4	4	4 1/4	3 7/8	13
	5	3 1/2-12	4 3/4-12	5-12	5	5.749	1	4 1/4	1	6 1/4	4 7/8	1/4	8 1/2	2 1/4	4	4 1/4	3 7/8	13
	5 1/2	4-12	5 1/4-12	5 1/2-12	5 1/2	6.249	1	4 5/8	1	6 3/4	5 3/8	1/4	9 1/2	2 1/4	4	4 1/4	3 7/8	13
20	3 1/2	2 1/2-12	3 1/4-12	3 1/2-12	3 1/2	4.249	1	3	3/4	5	3 3/8	1/2	5 1/2	2 1/4	4 1/4	4 5/8	4 1/4	14 5/8
	4	3-12	3 3/4-12	4-12	4	4.749	1	3 3/8	1	5 1/4	3 7/8	1/4	7 1/2	2 1/4	4 1/4	4 5/8	4 1/4	14 5/8
	5	3 1/2-12	4 3/4-12	5-12	5	5.749	1	4 1/4	1	6 1/4	4 7/8	1/4	8 1/2	2 1/4	4 1/4	4 5/8	4 1/4	14 5/8
	5 1/2	4-12	5 1/4-12	5 1/2-12	5 1/2	6.249	1	4 5/8	1	6 3/4	5 3/8	1/4	9 1/2	2 1/4	4 1/4	4 5/8	4 1/4	14 5/8

NPT PORTS FURNISHED UNLESS OTHERWISE SPECIFIED  
FIRST ROD SIZE SHOWN FOR EACH BORE SIZE IS STANDARD ROD



# CLEVIS AND TRUNNION MOUNTED CYLINDERS

## 14" TO 20" BORE SERIES JHD AND LSSL AIR CYLINDERS

AVAILABLE IN STANDARD CONSTRUCTION AND ALL STAINLESS STEEL DESIGN!

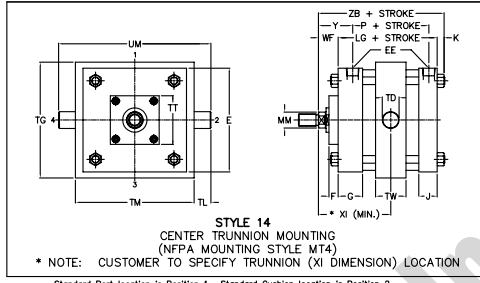
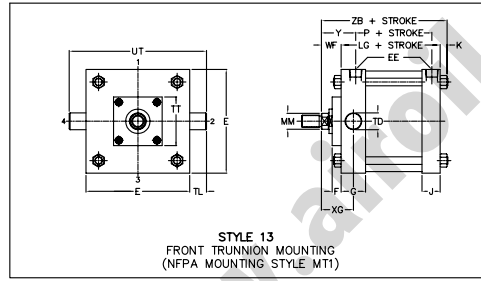
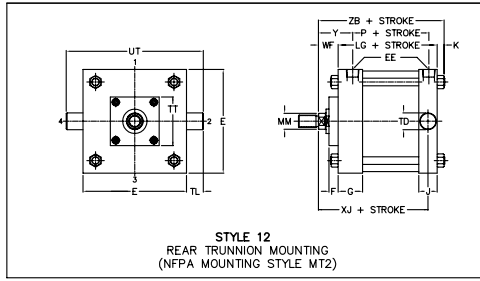
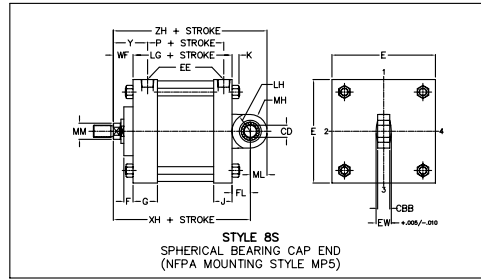
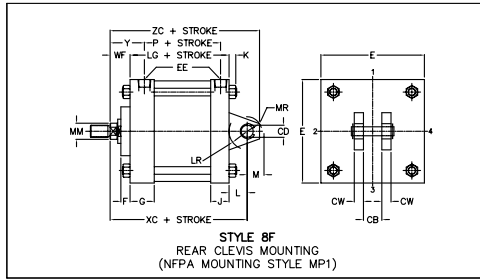

**NOTE:**  
THE 14" BORE USES FOUR (4) TIE RODS.  
BORE SIZES 16"-18"-20" USE EIGHT (8) TIE RODS.  
(SEE ILLUSTRATIONS ON P.29)

For ROD END Styles and dimensional drawings, see p.30

### ENVELOPE AND MOUNTING DIMENSIONS NOT AFFECTED BY ROD DIAMETER

BORE	NUM. TIE RODS	CB	CBB	CD * +0.000 -0.002	CW	E	EE (NPTF)	EW	FL	G	J	K	L	LH	LR	M	MH	ML	MR	TD ** +0.000 -0.001	TL	TG	TM	TW	UM	UT	P	LG	ADD STROKE
14	4	2 1/2	1 1/2	2.000	1 1/4	14 3/4	1 1/4	1 3/4	2 1/2	2 3/4	2 1/4	3/4	2 1/2	2 1/4	2 1/4	2	3	3	2 3/16	2.000	2	16	16 1/4	3 1/2	20 1/4	18 3/4	8 1/8	5 1/2	
16	8	3	1 7/8	2.500	1 1/2	17 1/2	1 1/4	2 3/16	3	2 3/4	2 3/4	7/8	3	2 3/4	2 1/2	3 1/2	3 1/2	2 5/8	2.500	2 1/2	-	-	-	22 1/2	8 7/8	5 3/4			
18	8	3	2 1/4	3.000	1 1/2	19 1/2	1 1/2	2 5/8	3 1/4	3 1/4	3 1/4	7/8	3 1/4	3	3 1/16	2 3/4	4 1/4	4 1/4	2 7/8	3.000	3	-	-	-	25 1/2	9 7/8	6 3/8		
20	8	3	2 1/4	3.000	1 1/2	21 1/2	2	2 5/8	3 1/4	3 3/4	3 3/4	1	3 1/4	3	3 1/16	2 3/4	4 1/4	4 1/4	2 7/8	3.500	3 1/2	-	-	-	28 1/2	11 3/8	7 3/8		

\* CD IS PIN DIAMETER \*\* TD IS TRUNNION PIN DIAMETER

### DIMENSIONS AFFECTED BY ROD DIAMETER

BORE	ROD DIA. MM	THREAD SIZE			ROD AND PILOT DIMENSIONS										ENVELOPE DIMENSIONS									
		KK STD	CC	FF	A	B +0.000 -0.002	C	D	F	LA	NA	V	TT	WF	Y	XG	XI MIN.	XC	XH	XJ	ZB	ZC	ZH	
																								ADD STROKE
14	2 1/2	1 7/8-12	2 1/4-12	2 1/2-12	3	3.124	1	2 1/16	3/4	4 1/2	2 3/8	1/2	4	2 1/4	3 13/16	3 5/8	6 3/4	12 7/8	12 7/8	9 1/4	11 1/8	14 7/8	15 7/8	
	3	2 1/4-12	2 3/4-12	3-12	3 1/2	3.749	1	2 5/8	3/4	5	2 7/8	1/2	5 1/2	2 1/4	3 13/16	3 5/8	6 3/4	12 7/8	12 7/8	9 1/4	11 1/8	14 7/8	15 7/8	
	3 1/2	2 1/2-12	3 1/4-12	3 1/2-12	3 1/2	4.249	1	3	3/4	5	3 3/8	1/2	5 1/2	2 1/4	3 13/16	3 5/8	6 3/4	12 7/8	12 7/8	9 1/4	11 1/8	14 7/8	15 7/8	
	4	3-12	3 3/4-12	4-12	4	4.749	1	3 3/8	1	5 1/4	3 7/8	1/4	7 1/2	2 1/4	3 13/16	3 5/8	6 3/4	12 7/8	12 7/8	9 1/4	11 1/8	14 7/8	15 7/8	
	3	2 1/4-12	2 3/4-12	3-12	3 1/2	3.749	1	2 5/8	3/4	5	2 7/8	1/2	5 1/2	2 1/4	3 13/16	3 5/8	-	14 1/8	14 1/8	9 3/4	12	16 5/8	17 5/8	
16	3 1/2	2 1/2-12	3 1/4-12	3 1/2-12	3 1/2	4.249	1	3	3/4	5	3 3/8	1/2	5 1/2	2 1/4	3 13/16	3 5/8	-	14 1/8	14 1/8	9 3/4	12	16 5/8	17 5/8	
	4	3-12	3 3/4-12	4-12	4	4.749	1	3 3/8	1	5 1/4	3 7/8	1/4	7 1/2	2 1/4	3 13/16	3 5/8	-	14 1/8	14 1/8	9 3/4	12	16 5/8	17 5/8	
	5	3 1/2-12	4 3/4-12	5-12	5	5.749	1	4 1/4	1	6 1/4	4 7/8	1/4	8 1/2	2 1/4	3 13/16	3 5/8	-	14 1/8	14 1/8	9 3/4	12	16 5/8	17 5/8	
18	3 1/2	2 1/2-12	3 1/4-12	3 1/2-12	3 1/2	4.249	1	3	3/4	5	3 3/8	1/2	5 1/2	2 1/4	4	3 7/8	-	15 3/8	15 3/8	10 1/2	13	18 1/8	19 5/8	
	4	3-12	3 3/4-12	4-12	4	4.749	1	3 3/8	1	5 1/4	3 7/8	1/4	7 1/2	2 1/4	4	3 7/8	-	15 3/8	15 3/8	10 1/2	13	18 1/8	19 5/8	
	5	3 1/2-12	4 3/4-12	5-12	5	5.749	1	4 1/4	1	6 1/4	4 7/8	1/4	8 1/2	2 1/4	4	3 7/8	-	15 3/8	15 3/8	10 1/2	13	18 1/8	19 5/8	
	5 1/2	4-12	5 1/4-12	5 1/2-12	5 1/2	6.249	1	4 5/8	1	6 3/4	5 3/8	1/4	9 1/2	2 1/4	4	3 7/8	-	15 3/8	15 3/8	10 1/2	13	18 1/8	19 5/8	
20	3 1/2	2 1/2-12	3 1/4-12	3 1/2-12	3 1/2	4.249	1	3	3/4	5	3 3/8	1/2	5 1/2	2 1/4	4 1/4	4 1/8	-	16 7/8	16 7/8	11 3/4	14 5/8	19 5/8	21 1/8	
	4	3-12	3 3/4-12	4-12	4	4.749	1	3 3/8	1	5 1/4	3 7/8	1/4	7 1/2	2 1/4	4 1/4	4 1/8	-	16 7/8	16 7/8	11 3/4	14 5/8	19 5/8	21 1/8	
	5	3 1/2-12	4 3/4-12	5-12	5	5.749	1	4 1/4	1	6 1/4	4 7/8	1/4	8 1/2	2 1/4	4 1/4	4 1/8	-	16 7/8	16 7/8	11 3/4	14 5/8	19 5/8	21 1/8	
	5 1/2	4-12	5 1/4-12	5 1/2-12	5 1/2	6.249	1	4 5/8	1	6 3/4	5 3/8	1/4	9 1/2	2 1/4	4 1/4	4 1/8	-	16 7/8	16 7/8	11 3/4	14 5/8	19 5/8	21 1/8	

NPT PORTS FURNISHED UNLESS OTHERWISE SPECIFIED FIRST ROD SIZE SHOWN FOR EACH BORE SIZE IS STANDARD



# FLANGE MOUNTED CYLINDERS

## 14" TO 20" BORE SERIES JHD AND LSSL AIR CYLINDERS

**AVAILABLE IN STANDARD CONSTRUCTION AND ALL STAINLESS STEEL DESIGN!**

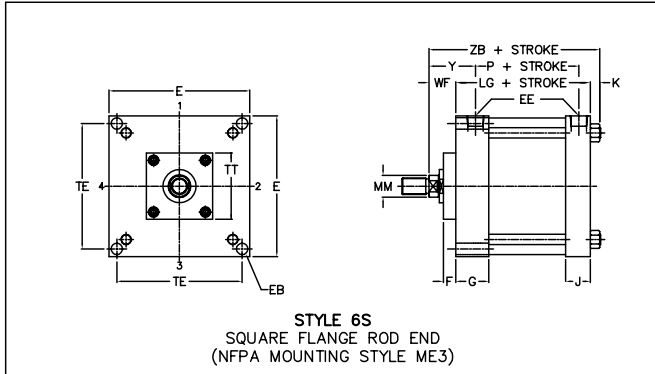

**STYLE 6S**  
SQUARE FLANGE ROD END  
(NFPA MOUNTING STYLE ME3)

Standard Port location is Position 1.  
Standard Cushion location is Position 2.

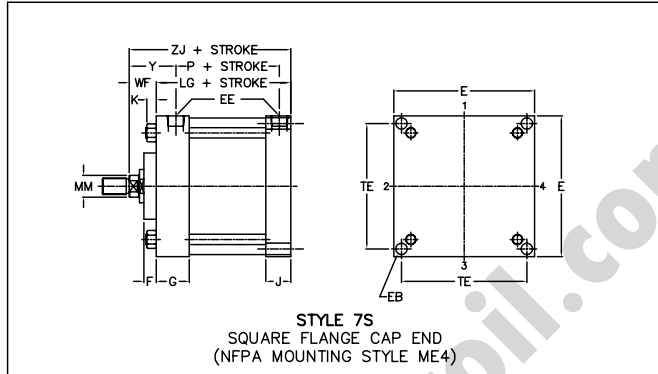

**STYLE 7S**  
SQUARE FLANGE CAP END  
(NFPA MOUNTING STYLE ME4)

Standard Port location is Position 1.  
Standard Cushion location is Position 2.

**NOTES:**

- 1) THE 14" BORE USES FOUR (4) TIE RODS. BORE SIZES 16"-18"-20" USE EIGHT (8) TIE RODS. (SEE ILLUSTRATIONS ON P.29)
- 2) USE OF SOCKET HEAD CAP SCREWS IS PREFERRED FOR MOUNTING STYLES 6S AND 7S IN 14" TO 20" BORES DUE TO INTERFERENCE WITH THE TIE RODS AND HEX BOLT HEADS.
- 3) ALL FLANGE MOUNTED CYLINDERS SHOULD BE MOUNTED USING HIGH STRENGTH MOUNTING BOLTS.

For **ROD END** Styles and dimensional drawings, see p.30

### ENVELOPE AND MOUNTING DIMENSIONS NOT AFFECTED BY ROD DIAMETER

BORE	NUM. TIE RODS	E	EE (NPTF)	EB	G	J	K	TE	LG	P
									ADD STROKE	
14	4	14 3/4	1 1/4	15/16	2 3/4	2 1/4	3/4	12 7/8	8 1/8	5 1/2
16	8	17 1/2	1 1/4	1 5/16	2 3/4	2 3/4	7/8	14 3/4	8 7/8	5 3/4
18	8	19 1/2	1 1/2	1 9/16	3 1/4	3 1/4	7/8	16 1/2	9 7/8	6 3/8
20	8	21 1/2	2	1 13/16	3 3/4	3 3/4	1	18 1/4	11 3/8	7 3/8

### DIMENSIONS AFFECTED BY ROD DIAMETER

BORE	ROD DIA. MM	THREAD SIZE			ROD AND PILOT DIMENSIONS								ENVELOPE DIMENSIONS				
		KK STD	CC	FF	A	B +0.000 -0.002	C	D	F	LA	NA	V	TT	WF	Y	ZB	ZJ
		ADD STROKE															
14	2 1/2	1 7/8-12	2 1/4-12	2 1/2-12	3	3.124	1	2 1/16	3/4	4 1/2	2 3/8	1/2	4	2 1/4	3 13/16	11 1/8	10 3/8
	3	2 1/4-12	2 3/4-12	3-12	3 1/2	3.749	1	2 5/8	3/4	5	2 7/8	1/2	5 1/2	2 1/4	3 13/16	11 1/8	10 3/8
	3 1/2	2 1/2-12	3 1/4-12	3 1/2-12	3 1/2	4.249	1	3	3/4	5	3 3/8	1/2	5 1/2	2 1/4	3 13/16	11 1/8	10 3/8
	4	3-12	3 3/4-12	4-12	4	4.749	1	3 3/8	1	5 1/4	3 7/8	1/4	7 1/2	2 1/4	3 13/16	11 1/8	10 3/8
16	3	2 1/4-12	2 3/4-12	3-12	3 1/2	3.749	1	2 5/8	3/4	5	2 7/8	1/2	5 1/2	2 1/4	3 13/16	12	11 1/8
	3 1/2	2 1/2-12	3 1/4-12	3 1/2-12	3 1/2	4.249	1	3	3/4	5	3 3/8	1/2	5 1/2	2 1/4	3 13/16	12	11 1/8
	4	3-12	3 3/4-12	4-12	4	4.749	1	3 3/8	1	5 1/4	3 7/8	1/4	7 1/2	2 1/4	3 13/16	12	11 1/8
18	3 1/2	2 1/2-12	3 1/4-12	3 1/2-12	3 1/2	4.249	1	3	3/4	5	3 3/8	1/2	5 1/2	2 1/4	4	13	12 1/8
	4	3-12	3 3/4-12	4-12	4	4.749	1	3 3/8	1	5 1/4	3 7/8	1/4	7 1/2	2 1/4	4	13	12 1/8
	5	3 1/2-12	4 3/4-12	5-12	5	5.749	1	4 1/4	1	6 1/4	4 7/8	1/4	8 1/2	2 1/4	4	13	12 1/8
	5 1/2	4-12	5 1/4-12	5 1/2-12	5 1/2	6.249	1	4 5/8	1	6 3/4	5 3/8	1/4	9 1/2	2 1/4	4	13	12 1/8
20	3 1/2	2 1/2-12	3 1/4-12	3 1/2-12	3 1/2	4.249	1	3	3/4	5	3 3/8	1/2	5 1/2	2 1/4	4 1/4	14 5/8	13 5/8
	4	3-12	3 3/4-12	4-12	4	4.749	1	3 3/8	1	5 1/4	3 7/8	1/4	7 1/2	2 1/4	4 1/4	14 5/8	13 5/8
	5	3 1/2-12	4 3/4-12	5-12	5	5.749	1	4 1/4	1	6 1/4	4 7/8	1/4	8 1/2	2 1/4	4 1/4	14 5/8	13 5/8
	5 1/2	4-12	5 1/4-12	5 1/2-12	5 1/2	6.249	1	4 5/8	1	6 3/4	5 3/8	1/4	9 1/2	2 1/4	4 1/4	14 5/8	13 5/8

NPT PORTS FURNISHED UNLESS OTHERWISE SPECIFIED  
FIRST ROD SIZE SHOWN FOR EACH BORE SIZE IS STANDARD ROD



**ORDERING INFORMATION**  
**PART NUMBER CODE FOR AIR CYLINDERS**  
**SERIES JHD STANDARD CONSTRUCTION AIR CYLINDER**  
**SERIES LSSL ALL-STAINLESS STEEL AIR CYLINDER**  
**SERIES JHDA AIR MOTORS**

J 2 0 S 0 2 7 5 A B 0 2 0 0

**MODEL CODE: \***  
 J, for standard  
 JHD  
 air cylinder  
 L, for all stainless  
 steel LSSL  
 air cylinder

**BORE SIZE:**

For 1" use 01  
 For 1 1/2" use 15  
 For 2" use 20  
 For 2 1/2" use 25  
 For 3 1/4" use 32  
 For 4" use 40  
 For 5" use 50  
 For 6" use 60  
 For 8" use 80  
 For 10" use 10  
 For 12" use 12  
 For 14" use 14  
 For 16" use 16  
 For 18" use 18  
 For 20" use 02

**ROD DIAMETER:**

For Standard, use S  
 For 1st Oversize, use 1  
 For 2nd Oversize, use 2  
 For 3rd Oversize, use 3

**STROKE:**

Stroke in inches

**FRACTIONAL STROKE:**

In 0.01 inch increments

**SPECIAL INFORMATION:**

For no modifications, use 00  
 For Air Motor, use 01  
 For special items, use 0S  
 (CONSULT LEHIGH)

**MOUNTING STYLE:**

For #1 (MX0) use 01  
 For #2 (MX1) use 02  
 For #3 (MX2) use 03  
 For #4 (MX3) use 04  
 For #5 (MS1) use 05  
 For #6 (MF1) use 06  
 For #6S (ME3) use 6S  
 For #7 (MF2) use 07  
 For #7S (ME4) use 7S  
 For #8F (MP1) use 8F  
 For #8D (MP2) use 8D  
 For #8M (MP3) use 8M  
 For #8S (MP5) use 8S  
 For #9 (MS4) use 09  
 For #10 (MNR1) use 10  
 For #11 (MS2) use 11  
 For #12 (MT2) use 12  
 For #13 (MT1) use 13  
 For #14 (MT4) use 14  
 For #15 (MS7) use 15  
 For #16 (MF5) use 16  
 For #17 (MF6) use 17

**CUSHIONS:**

For Cushions both ends, use B  
 For Cushions cap end, use R  
 For Cushions rod end, use F  
 For no cushions, use N

**ROD END STYLE:**

For Small Male (Standard), use A  
 For Female, use B  
 For Full Male, use C  
 For Intermediate Male, use D  
 For Flanged Rod End, use F  
 For Plain Rod End, use P

\* SEE APPLICABLE PRODUCT SECTION FOR ALL OTHER PRODUCTS; e.g. SBA, MSBA, POSITION SENSING, BOOSTER, INTENSIFIER, SPRING CYLINDER

**Cylinder Designation for Sample Code Above**

Series JHD Standard Construction Air Cylinder – 2" Dia. Bore  
 5/8" Dia. Rod – 2.75" Stroke – Standard Small Male Rod End (7/16–20)  
 Cushioned Both Ends – #2 (MX1) Mounting





**VALVE ACTUATOR CYLINDER**  
**8" to 20" BORE SERIES VAC AIR CYLINDER**  
**STANDARD IN STEEL, AVAILABLE IN ALL-STAINLESS STEEL!**

8" to 14" Bores to 250 PSI  
 16" to 20" Bores to 125 PSI

**VALVE ACTUATOR CYLINDER**



Lehigh's uncompromising quality is built into this series of light duty cylinder designed to meet industry's requirements for valve and guided load actuation.

As with our heavy duty air cylinder series, the VAC cylinder construction includes our exclusive MIRACALUBE® self-lubricated system. This unique system meters a specially formulated, non-toxic, ingestible, low vapor pressure lubricant, totally solvent-free. Unlike contaminating air line lubricants, Lehigh MIRACALUBE® will not mist or atomize. Being solvent-free, it will not dissolve seals or fuse lipseals to the tube I.D. if the piston remains in one position for an extended length of time.

Valve actuation applications often require more than the catalog standard design. . .

- If a fail-safe position is needed should pneumatic pressure be lost, contact us for a spring offset option.
- A position indicator may be important. A rear piston rod can be added that actuates a limit switch.
- Perhaps you can't use pneumatic pressure at all. Let us design the VAC for water media.

Our custom designs are created for specific applications. If the standard doesn't fit, contact us to get just the right features designed in.

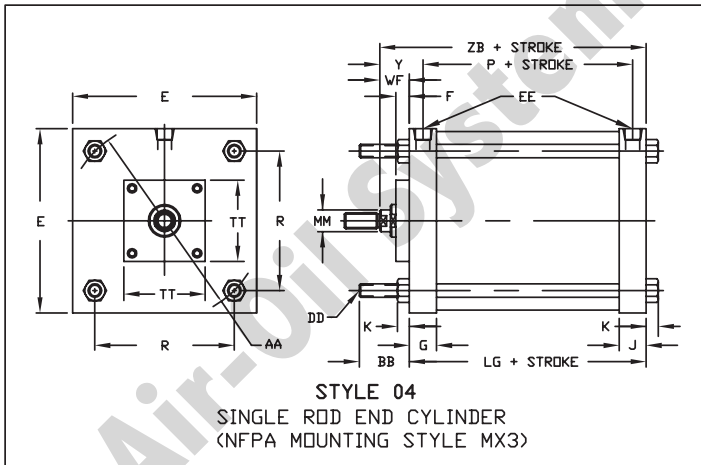

**MOUNTING DESCRIPTION**

MOUNTING STYLE	NFFPA MOUNTING STYLE	DESCRIPTION
01	MX0	NO TIE ROD EXTENSIONS
02	MX1	TIE RODS EXTENDED BOTH ENDS
03	MX2	TIE RODS EXTENDED CAP END
04	MX3	TIE RODS EXTENDED ROD END
DRE 01	MDX0	NO TIE ROD EXTENSIONS
DRE 02	MDX1	TIE RODS EXTENDED BOTH ENDS
DRE 03	MDX3	TIE RODS EXTENDED ONE END

**ENVELOPE AND MOUNTING DIMENSIONS NOT AFFECTED BY ROD DIAMETER**

BORE	AA	BB	DD	E	EE NPTF	F	G	J	K	R	LG	P
											ADD STROKE	
8	9.10	2 5/8	5/8-18	8 1/2	1/2	5/8	1 1/4	1 1/4	9/16	6.44	4 1/8	3
10	11.20	3	3/4-16	10 5/8	1/2	5/8	1 1/4	1 1/4	11/16	7.92	4 5/8	3 19/32
12	13.30	3	3/4-16	12 3/4	1/2	5/8	1 1/4	1 1/4	11/16	9.40	5 1/8	4 3/32
14	15.40	3 3/16	7/8-14	14 3/4	3/4	3/4	1 3/4	1 3/4	3/4	10.90	6 5/8	4 7/8
16	18.19	3 5/8	1-14	17 1/2	1	3/4	2	2	7/8	12.86	7 3/8	5 7/16
18	20.19	4 1/8	1 1/8-12	19 1/2	1 1/4	3/4	2 1/2	2 1/2	1	14.27	8 3/8	5 15/16
20	22.31	4 1/2	1 1/4-12	21 1/2	1 1/2	3/4	2 3/4	2 3/4	1 1/16	15.77	9 3/8	6 3/4

# VALVE ACTUATOR CYLINDER

## 8" to 20" BORE SERIES VAC AIR CYLINDER (Cont.)

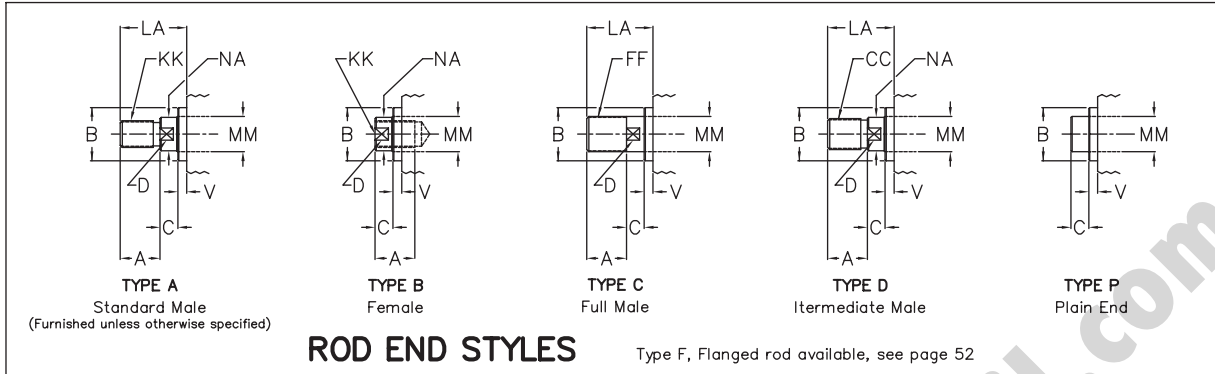

### DIMENSIONS AFFECTED BY ROD DIAMETER

BORE	ROD DIA. MM	MAX. * STROKE LENGTH	THREAD SIZE			A	B +.000 - .002	C	D	LA	NA	TT	V	WF	Y	ZB PLUS STROKE
			KK STD	CC	FF											
8	1	30 INCHES	3/4-16	7/8-14	1-14	1 5/8	1.499	1/2	7/8	2 3/8	15/16	3 3/4	1/4	1 3/8	1 15/16	5 1/2
	1 3/8	70 INCHES	1-14	1 1/4-12	1 3/8-12	1 5/8	1.999	5/8	1 1/8	2 5/8	1 5/16	3 3/4	3/8	1 5/8	2 3/16	5 3/4
10	1	24 INCHES	3/4-16	7/8-14	1-14	1 5/8	1.499	1/2	7/8	2 3/8	15/16	3 3/4	1/4	1 3/8	1 7/8	6
	1 3/8	52 INCHES	1-14	1 1/4-12	1 3/8-12	1 5/8	1.999	5/8	1 1/8	2 5/8	1 5/16	3 3/4	3/8	1 5/8	2 1/8	6 1/4
12	1 3/8	28 INCHES	1-14	1 1/4-12	1 3/8-12	2	1.999	5/8	1 1/8	3	1 5/16	3 3/4	3/8	1 5/8	2 1/8	6 3/4
	1 3/4	64 INCHES	1 1/4-12	1 1/2-12	1 3/4-12	2	2.374	3/4	1 1/2	3 1/4	1 11/16	3 3/4	1/2	1 7/8	2 3/8	7
14	1 3/4	64 INCHES	1 1/4-12	1 1/2-12	1 3/4-12	2	2.374	3/4	1 1/2	3 1/8	1 11/16	4	3/8	1 7/8	2 3/4	8 1/2
	2	85 INCHES	1 1/2-12	1 3/4-12	2-12	2	2.624	7/8	1 11/16	3 1/4	1 15/16	4	3/8	2	2 7/8	8 5/8
16	2	75 INCHES	1 1/2-12	1 3/4-12	2-12	3	2.624	7/8	1 11/16	4 1/4	1 15/16	4	3/8	2	3	9 3/8
	2 1/2	85 INCHES	1 7/8-12	2 1/4-12	2 1/2-12	3	3.124	1	2 1/16	4 1/2	2 3/8	4	1/2	2 1/4	3 1/4	9 5/8
18	2 1/2	85 INCHES	1 7/8-12	2 1/4-12	2 1/2-12	3 1/2	3.124	1	2 1/16	5	2 3/8	4	1/2	2 1/4	3 1/2	10 5/8
	3	85 INCHES	2 1/4-12	2 3/4-12	3-12	3 1/2	3.749	1	2 5/8	5	2 7/8	5 1/2	1/2	2 1/4	3 1/2	10 5/8
20	3	85 INCHES	2 1/4-12	2 3/4-12	3-12	3 1/2	3.749	1	2 5/8	5	2 7/8	5 1/2	1/2	2 1/4	3 9/16	11 5/8
	3 1/2	85 INCHES	2 1/2-12	3 1/4-12	3 1/2-12	3 1/2	4.249	1	3	5	3 3/8	5 1/2	1/2	2 1/4	3 9/16	11 5/8

FIRST ROD SIZE LISTED FOR EACH BORE SIZE IS STANDARD ROD  
 \* MAX STROKE LENGTHS SHOWN ARE FOR RIGIDLY GUIDED LOADS AT MAX 120 PSI INPUT PRESSURE

### ORDERING INFORMATION

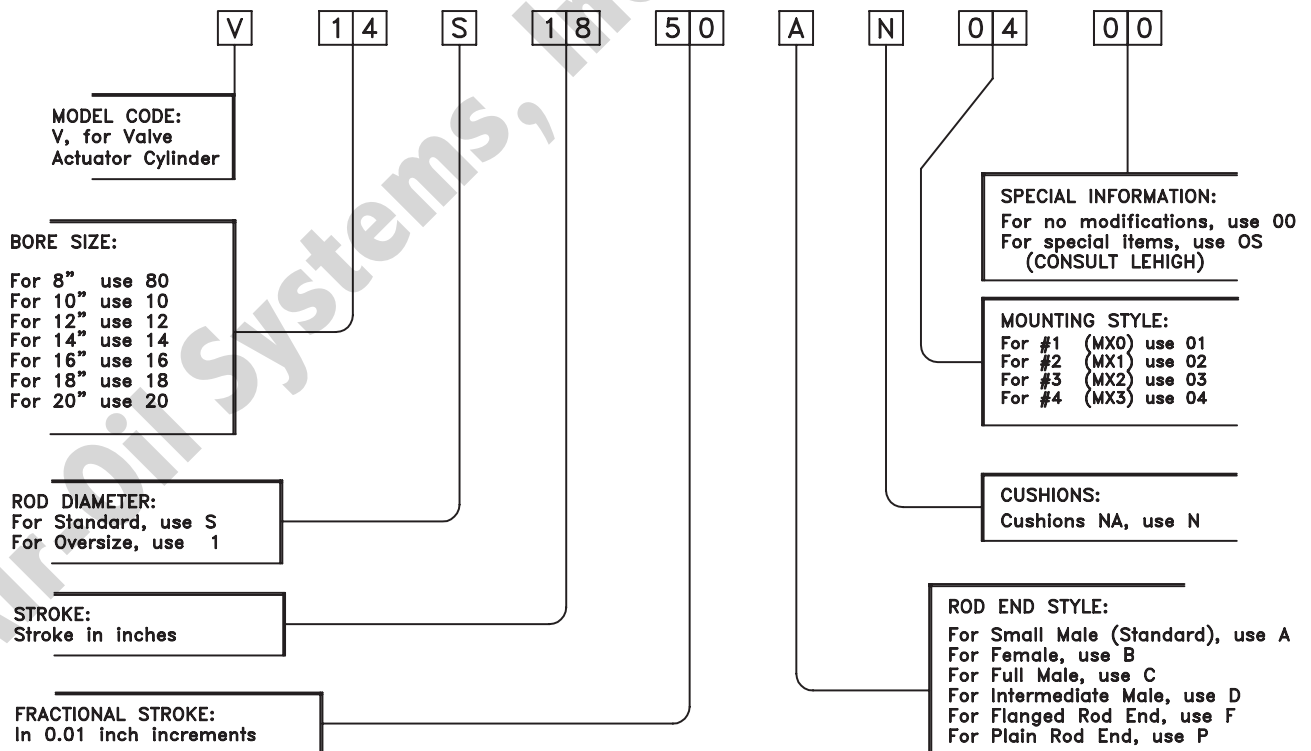

### Cylinder Designation for Sample Code Above

Series VAC Valve Actuator Air Cylinder – 14" Dia. Bore – 1 3/4" Dia. Rod – 18.50" Stroke  
 Standard Small Male Rod End (1 1/4 - 12) – Non-Cushioned – #4 (MX3) Mounting



## SPRING CYLINDERS

FAIL-SAFE OPTION FOR EXTEND OR RETRACT POSITION  
AVAILABLE IN ALL SERIES OF CYLINDERS, INCLUDING STAINLESS STEEL!



### SPRING CYLINDERS

**Fail-safe positioning** – a condition where force is provided to the cylinder to move a load to a predetermined point when pressure is removed.

**Spring designed cylinders** may be the simplest way to accomplish this.

In most cases, a mechanical spring is the only device that can be coupled to a cylinder to consistently deliver a specific design force to hold a desired position when input pressure is lost – and retain that force for as long as the integrity of the cylinder assembly is maintained.

**Spring extend** – a spring is used so that a cylinder will stroke to the fully extended position when input pressure is removed from the rod end port. Likewise, for **spring retract**, the cylinder will stroke to the fully retracted position when pressure is removed from the cap end port.

Applications for cylinders designed with springs are virtually unlimited, many involving the important fail-safe function. Examples of uses include process-valve operators, conveyor-shift positioners, damper controls, collating machines, steam-control devices, and others where safety requires that some process absolutely must stop if system power is lost.

### EXAMPLES OF SPRING CYLINDER DESIGN

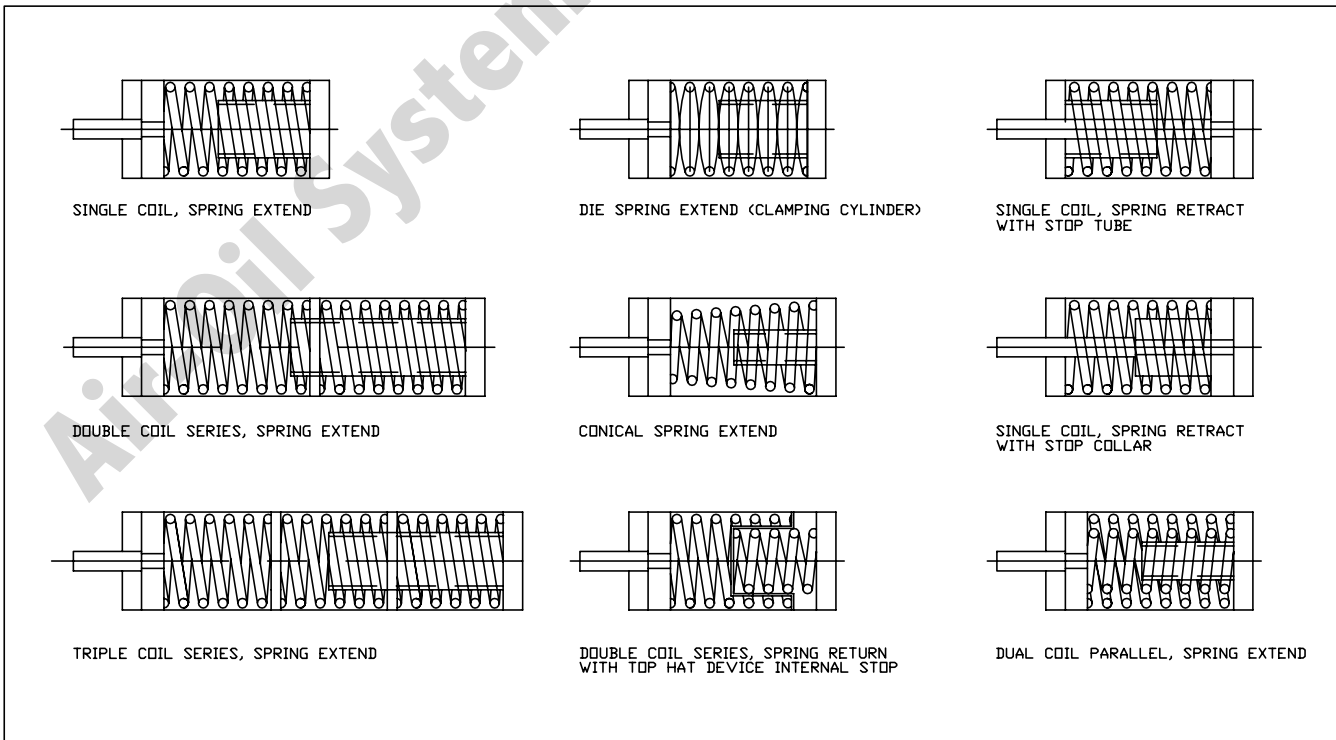

# SPRING CYLINDERS

## FAIL-SAFE OPTION FOR EXTEND OR RETRACT POSITION (Cont.)

### DESIGNING THE SPRING CYLINDER

In a *Spring Extend* or a *Spring Retract* cylinder, a spring is installed inside the cylinder tube. The spring is compressed when the cylinder is assembled. The *Spring Preload* is the force this initial compression develops. The *Spring Preload* is the force the cylinder will develop in the fail-safe position without system pressure.

It is important to correctly identify all external forces acting upon the cylinder. These external forces could include linkage friction, seal friction external to the cylinder, or process loads that act only in the extend or retract stroke. If the external forces are under-estimated, the system pressure may not be sufficient to stroke the cylinder.

It is also important to accurately determine the minimum system pressure available. The system pressure determines the bore of the spring-loaded cylinder. If the system pressure is over-estimated, the cylinder may not fully stroke.

Correctly applying the spring cylinder requires some thoughtful design decisions. Yet, the design process is not complicated if complete preliminary information is provided. Such information should include:

*Operating Medium* – Pneumatic

*Minimum Available System Pressure* – Affects the bore size

*Required Cylinder Working Stroke* – The resultant cylinder length depends on the bore, stroke, and spring combination. As a rule-of-thumb, a spring cylinder's total stroke will be approximately twice the actual working stroke required. Longer lengths are not uncommon.

*Spring Preload* – The force (lbs) the cylinder develops in the fail-safe position

Other usual design elements of the cylinder also need to be specified; i.e., rod diameter, rod end style, mounting style, port type and port positions.

There are two additional useful terms that need not be supplied as application data, but are calculated for the design:

*Spring Rate* – The amount of force (lbs) developed by the spring per inch of compression

*Spring Final Load* – The force (lbs) developed by the spring when the cylinder is fully stroked away from its fail-safe position

### ORDERING INFORMATION

The spring cylinder is a product engineered for a specific application. Please note, however, that this design is essentially a modification of any of our standard products. Therefore, you can consider the basic designs of our any of our cylinder series in your application, from our 3/4" diameter bore on up to our largest bore, including the valve actuation cylinder (VAC) and the all-stainless steel cylinder (LSSL). Contact Lehigh sales and engineering for help in selecting the best product solution for your requirement.





## JHDA AIR MOTOR AIR CYLINDER WITH MOUNTED VALVE

### JHDA 01 AIR MOTOR: 1" DIA. BORE

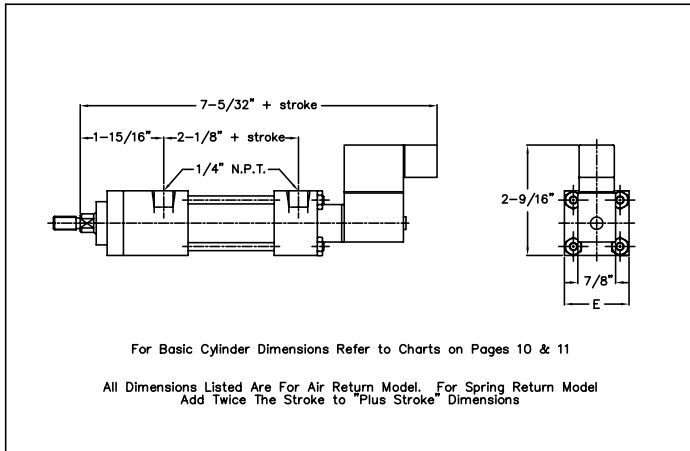

The JHDA 01 series air motor combines the rugged 1" dia. bore JHD 01 heavy duty air cylinder (pp.12-13) with an electric solenoid valve to create a cylinder and valve designed as a unit. One electrical connection and a single air supply line to the valve-in-head end of the cylinder simplifies installation. (For an air return model, a constant pressure air line must be connected to the rod end port of the cylinder.)

The standard valve used is a miniature 3-way solenoid operated valve, 110 volt, 60 cycle, with power consumption of 6 watts, continuous duty rated, Class A, molded coil. The electric connection is via spade terminal coil with ground per DIN 43650. Other coil voltage, connectors and enclosures are available.

The JHD01 cylinder mountings available are: 01, 04, 06, 09, 10, 11, 12, 13 (see pp. 12-13).

Consult factory for available options such as Miracalube<sup>®</sup>, spring return, and low pressure air operation, or for specials

### JHDA AIR MOTOR: 1 1/2" to 8" DIA. BORE

The JHDA series air motor in sizes from 1 1/2" to 8" dia bore features the JHD heavy duty air cylinder and Lehigh's 4-way Slide Valve to create a linear motion, quick-response power package. This combination unit eases installation and reduces power and maintenance costs.

A variety of cylinder mounting designs is available, as well as electric solenoid options. See pp.14-28 for JHD cylinder information and p.40 for description of the slide valve features and function.

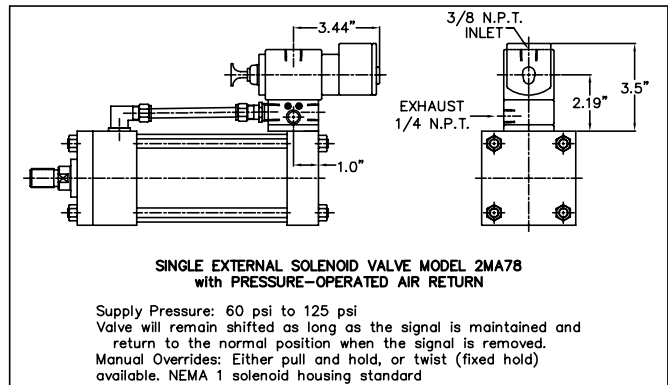
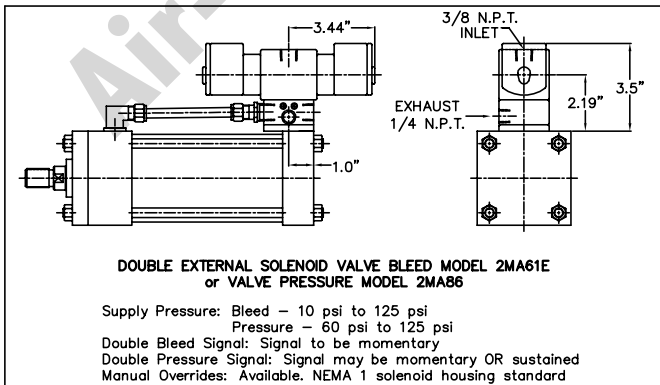
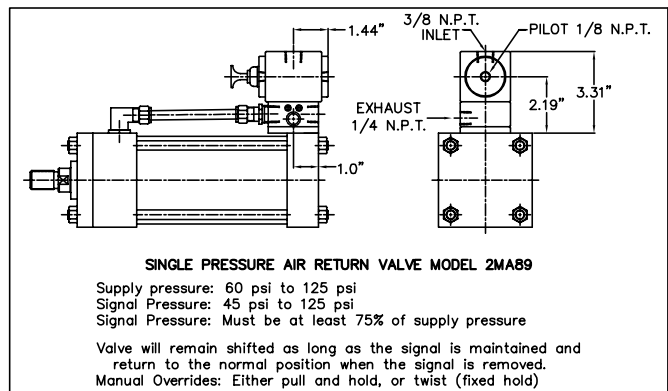
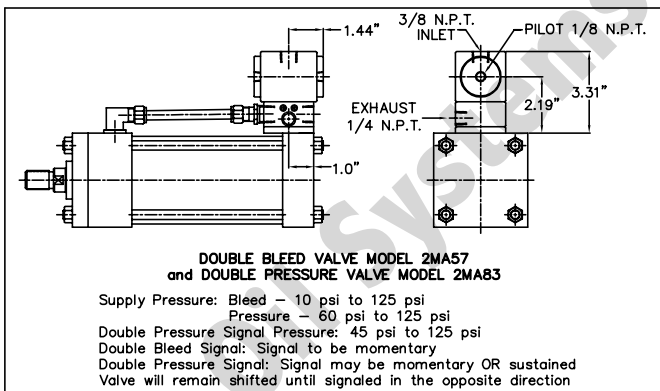



## JHDA AIR MOTOR (Cont.)

### SPECIAL ELECTRICAL COIL

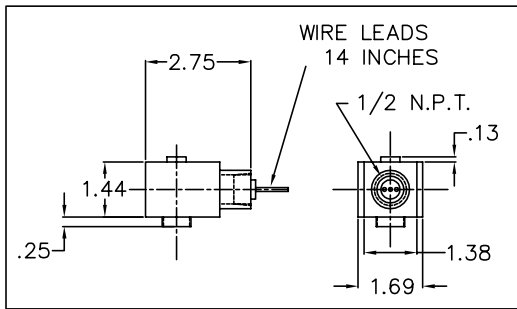

The special electrical coil shown at the left is available at extra charge. This water-tight and explosion proof enclosure is for indoor or outdoor use in NEMA groups 4, 6, 7C, 7D, 9E, 9F 9G and 12.

Piping arrangements are slightly different from the standard NEMA 1 housing.

Specify "NEMA 4, 7, and 9."

### AUTOMATIC AIR MOTOR

#### AUTOMATIC AIR MOTOR: 2" to 8" DIA. BORE

The JHDA series automatic air motor in sizes from 2" to 8" dia bore use built-in poppets to provide the signal for automatic operation of the JHD heavy duty air cylinder. External limit valves, micro-switches and push rods are eliminated. Mounted internally in the head, the poppets bleed off the signal side of the control valve when the piston depresses the poppet stem at the end of the stroke. Safe, reliable, and positive, the system provides a simple and low cost method of automatic operation.

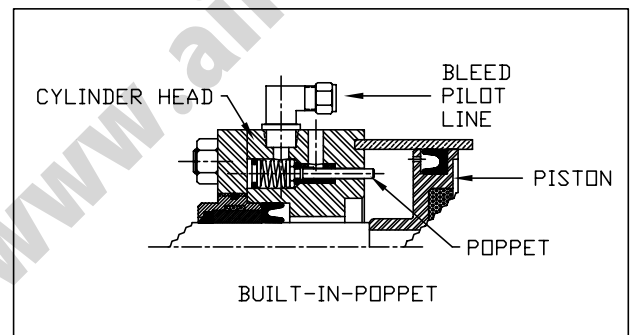

#### AUTOMATIC RETURN

Automatic return air motors have the built-in poppet in one head to automatically reverse the stroke from the normally retracted or normally extended position. The start cycle may be controlled by bleed or electrical signals

#### AUTOMATIC RECIPROCATING

Automatic reciprocating air motors have the built-in poppets in both heads and will maintain a reciprocating action as long as the air supplied is provided. A start-stop selector valve may be installed in either pilot line to assure that the stroke will terminate at one extreme or the other.

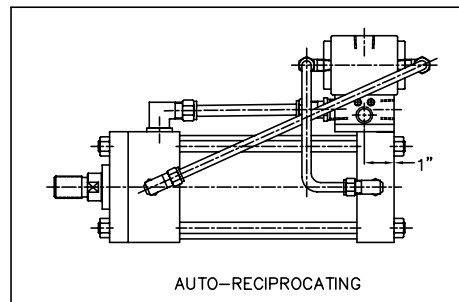
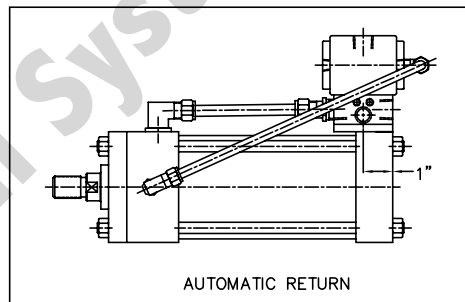

All the mounting styles of the JHD air cylinder are available for the automatic air motor.

The 2" dia. bore automatic air motor is limited to a maximum 5/8" diameter rod size. The 2-1/2" dia. bore automatic air motor is limited to a maximum 1" diameter rod size. There is no rod diameter limitation on larger bore sizes.

### ORDERING INFORMATION FOR JHDA AIR MOTORS

Use the ordering part number system shown on p.33 for the standard JHD air cylinder. The air motor is designated in the last two places with "01". Note the requirements and restrictions for the particular type of air motor described in this section, and add the applicable description; e.g., valve model, voltage, optional electric enclosure, automatic return air motor, etc.





# JHDA AIR MOTOR VALVES

## SERIES 2MA 4-WAY SLIDE VALVE

This exclusive pneumatic slide valve was designed specifically for Lehigh's line of Air Motors, yet it can be used in other air-powered device applications. It features **Fast Acting** operation . . . Up to 1,500 cycles per minute. It is **Reliable** . . . Operating even with improperly filtered air. It offers **Long Life** . . . The metal-to-metal seat is self-cleaning and operates for millions of cycles without significant wear. It is **Compact** . . . The short piston permits short valve length

### HOW IT OPERATES

The air-driven piston moves the slide. In each of its two positions, the slide opens one exhaust and one pressure port. The rate of flow of exhaust air is controlled by adjustable speed controls mounted in each of the two exhaust orifices. Both these orifices lead to a single exhaust port. The oversized actuating piston assures positive breakaway action, regardless of dirt in the operating areas or of low operating pressures. The slide effectively wipes the seat clean on each cycle, assuring a satisfactory seal even when used with improperly filtered air.

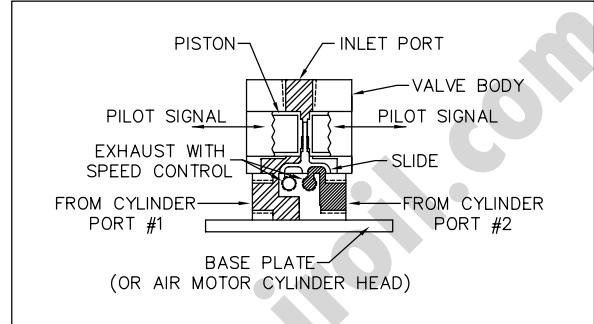

### CONSTRUCTION

**Piston:** Corrosion resistant anodized aluminum on all valves except 316 stainless steel on valve model 2MA57 AND 2MA61E double bleed valves. **Slide:** Lapped manganese bronze. **Valve Base:** Lapped nickel-plated ductile iron. **Valve Body:** Anodized heat treated aluminum.

### MOMENTARY BLEED PILOTS

The balanced piston is actuated by momentary unbalancing caused by the pilot air exhausting from the opposite signal port. The exhausting of pilot air is actuated by double solenoids integrally mounted on the valve (**Model 2MA61E**) or actuated by pilot air from valves in the customer's control circuit (**Model 2MA57**).

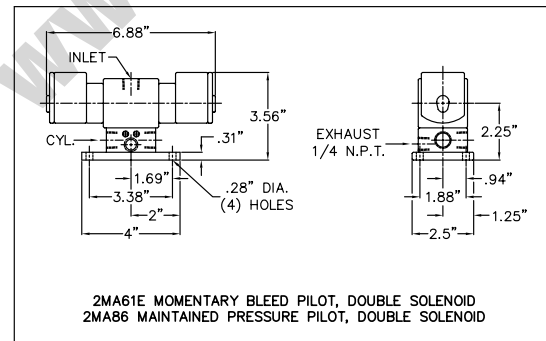

### MAINTAINED PRESSURE PILOTS

Positive maintained pilot pressure is used move the piston/slide mechanism, holding it in the desired actuated position. The pilot air is actuated by double solenoids integrally mounted on the valve (**Model 2MA86**) or actuated by pilot air from valves in the customer's control circuit (**Model 2MA83**).

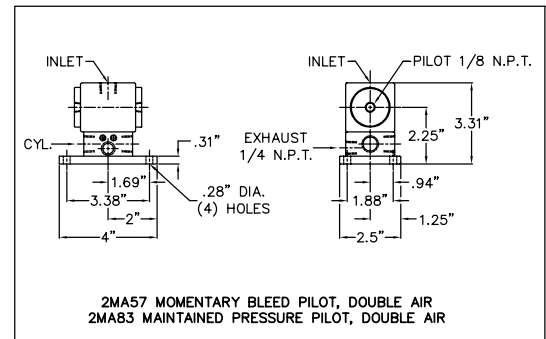

### AIR RETURN

The piston/slide mechanism can be supplied with one end having a smaller diameter in order to create a differential force when both sides are subjected to the same air pressure. The larger end will overpower the smaller end, causing movement toward the smaller end. When air in the larger diameter is exhausted, line pressure acting on the smaller end automatically activates the return. Control is by a single solenoid integrally mounted on the valve (**Model 2MA78**) or by single pilot air actuation from a valve in the customer's control circuit (**Model 2MA89**).

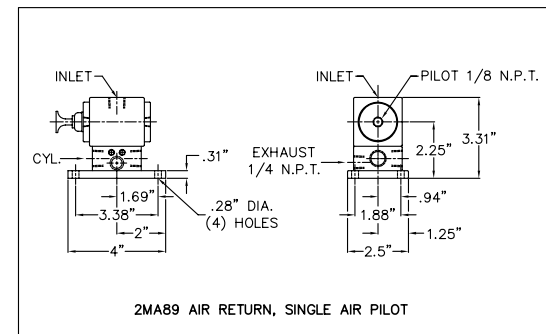
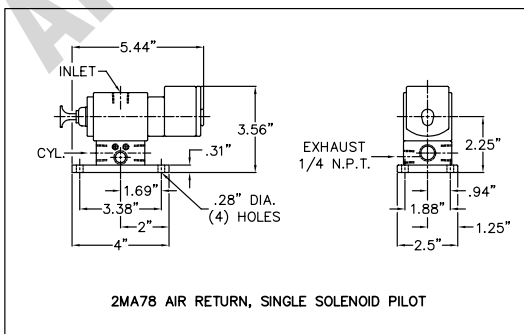



## POSITION SENSING CYLINDERS

There are a number of different position sensing devices for fluid power cylinders. Described below are four main types:

1. Tie rod mounted limit switches that are actuated by a magnetic piston
2. End-of-stroke proximity switches that are actuated by the cylinder cushion boss
3. Linear displacement transducer constructed as a probe inside the cylinder rod
4. Servo-type positioner for an air cylinder operating by force-balance

Each is briefly described below. Ordering instructions are provided for the tie rod mount limit switches. Please contact Lehigh sales and engineering for application assistance to define the ordering information for other positioning systems.

### TIE ROD MOUNTED LIMIT SWITCHES



This series of compact reed and hall effect switches is designed specifically as a rugged yet cost effective product to electrically sense cylinder stroke position.

Mounting is accomplished by clamping the switch to the cylinder tie rod with the self-adjusting clamp that comes with the switch.

A large number of custom circuits are featured to match your application requirements.

### DIMENSIONAL INFORMATION

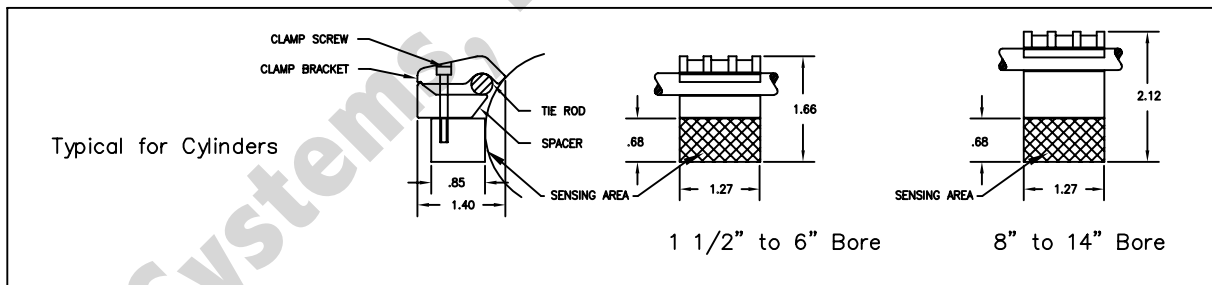

### TERMINATION INFORMATION

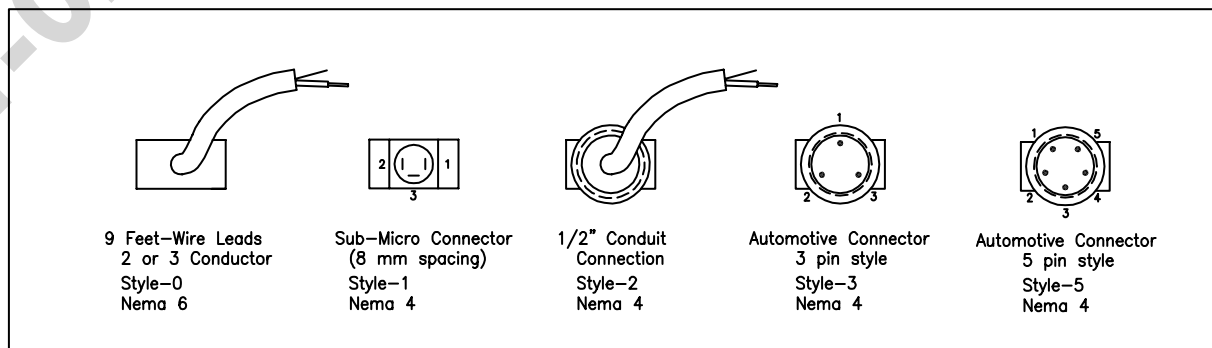

# POSITION SENSING CYLINDERS

## TIE ROD MOUNTED LIMIT SWITCHES (Cont.)

### TECHNICAL INFORMATION

Working Temperature: -22°F to +176°F  
 Vibration Resistance: 10 to 55 Hz  
 Life Expectancy at Full Load: 10,000,000 Cycles  
 Max. Switch Current: .25 amp to 4 amp  
 Repeatability: 0.001"

Shock Resistance: 30g @ 11 ms  
 Operating Time: OPERATE = 1.5 usec - .6 msec  
 RELEASE = .5 usec - .05 msec  
 NEMA Rating: NEMA 6 with Wire Lead Cables, Style 0  
 NEMA 4 with Connectors, Styles 1,2,3,5

**CAUTION - LOADS:** Failure to put a load in the line when testing or operating a switch can result in instantaneous failure! The typical application load for the switches is a Programmable Logic Controller (PLC). To test the switch prior to installation the following should apply: (A) For 24 VDC use a 2,000 Ohm, 1/2 Watt resistor or equivalent. (B) For 120 VAC/DC use a 12,000 Ohm, 2 Watt resistor or equivalent. (C) For a 240 VAC/DC use a 20,000 Ohm, 2 Watt resistor or equivalent.

### SWITCH MODULE TYPES

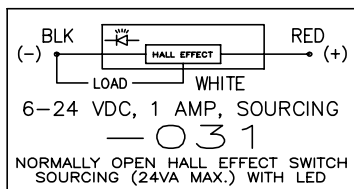
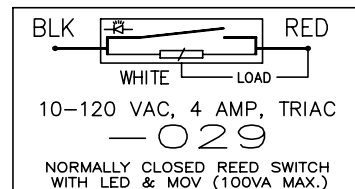
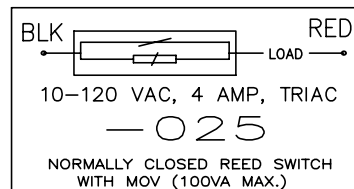
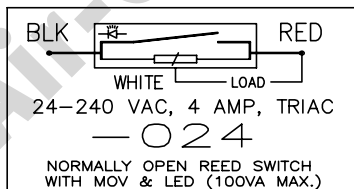
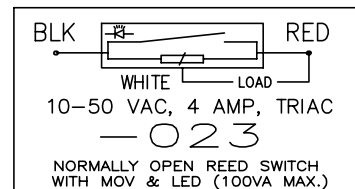
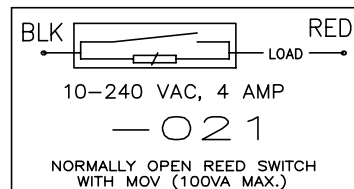
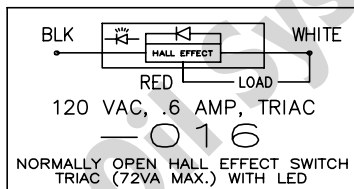
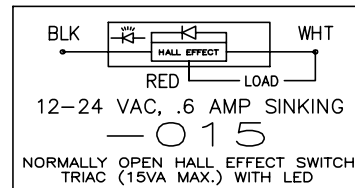
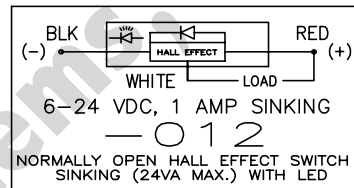
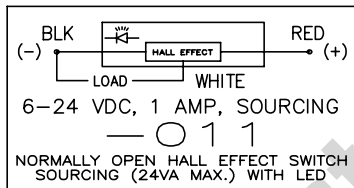
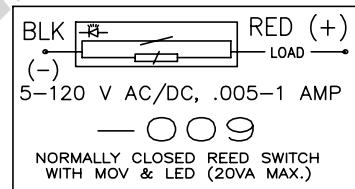
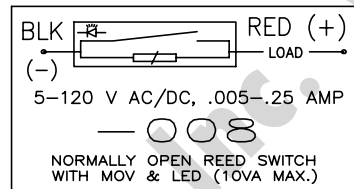
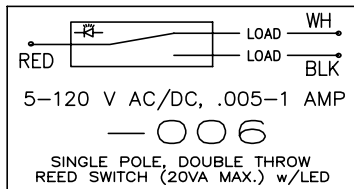
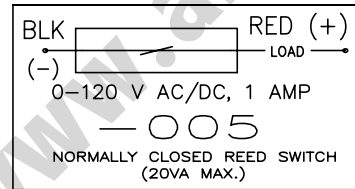
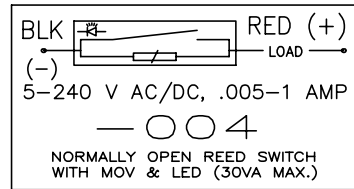
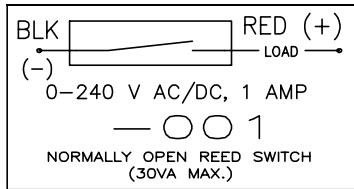

FOR APPLICATIONS WHICH CURRENTLY USE THE REED SWITCH MAGNET ORIENTATION AND REQUIRE A CHANGE TO THE HALL EFFECT STYLE SWITCH

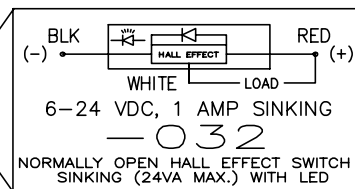

# POSITION SENSING CYLINDERS

## TIE ROD MOUNTED LIMIT SWITCHES (Cont.)

### ORDERING INFORMATION

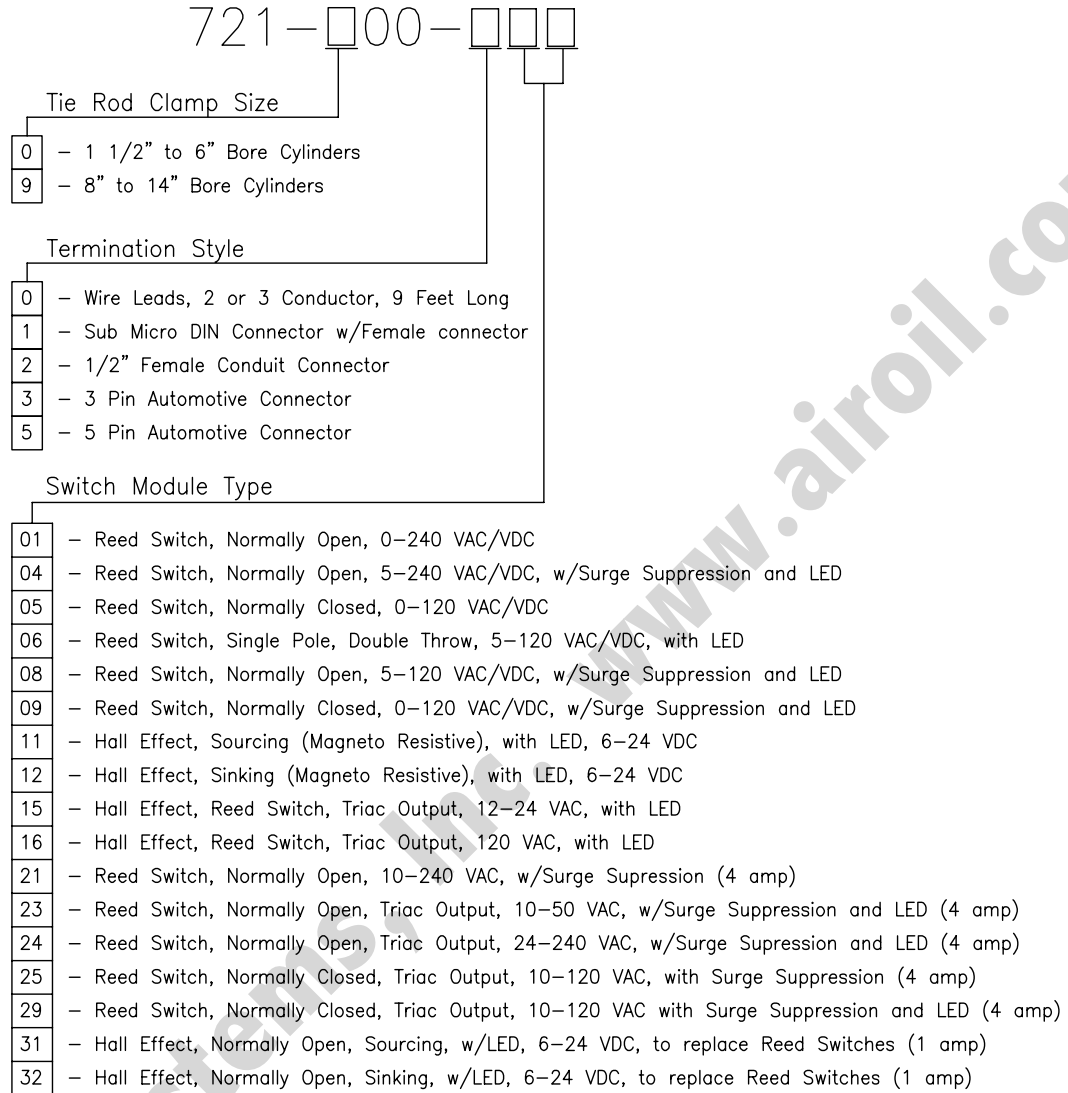

**Note:** When ordering a pneumatic cylinder for use with tie rod mount limit switches, in addition to the cylinder part number, specify "with magnetic piston for reed switch" and reference the reed switch P/N, or "with magnetic piston for hall effect switch" and reference the hall effect switch P/N. Switch not included in cylinder pricing. Order switch separately.

### INSTALLATION TIPS

1. Always use a load when testing the switches. Failure to use a load will permanently damage the switch.
2. Never test using a filament light bulb as a load. The severe inrush currents can cause switch failure or premature failure.
3. There are three types of loads (See "CAUTION - LOADS" on page 42):
  - a. Resistive loads - the inputs to a PC or PLC
  - b. Capacitive loads - long wire runs
  - c. Inductive loads - low power solenoids
4. To control the loads, the following may be necessary:
  - a. Resistive loads - confirm input parameters and compare to switch specifications
  - b. Capacitive loads - keep wire runs as short as possible and route wires away from current-carrying conductors
  - c. Inductive loads - use surge suppression versions of the switches or surge suppression coil connectors
5. Keep the area around the switch free from dirt and magnetic particles. The particles can affect the operation of the switch.
6. The switches can be used to indicate the end of piston travel or as intermediate stroke position indicators.
7. Be sure the sensing area of the switch is installed completely against the cylinder tube for proper operation.



## POSITION SENSING CYLINDERS

### END-OF-STROKE PROXIMITY SENSOR LINEAR DISPLACEMENT TRANSDUCER SERVO-POSITIONING

#### END-OF-STROKE PROXIMITY SENSOR, THREADED MOUNT

This type of switch signals the end-of stroke of the cylinder by sensing the ferrous cushion bosses on each side of the piston. The switch contains an internal magnet that operates a conventional single pole, double throw, form C switch. These O.D. threaded switches are mounted through the cylinder heads on approximately the same axial centerline as the ports.

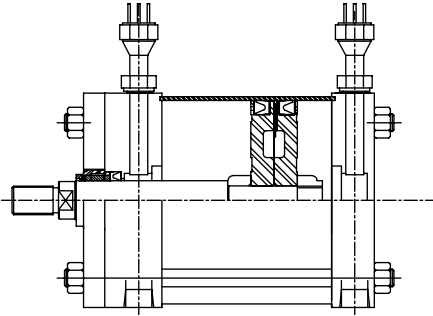

Contact Rating: 2 Amp @ 240 VAC  
3 Amp @ 24 VDC  
Response Time: 0.008 seconds  
Repeatability: 0.002" of set operating point under identical conditions  
Approvals: UL, CSA, BASEEFA and SA

---

#### LINEAR DISPLACEMENT TRANSDUCER

Linear position sensing provides a non-contact displacement transducer that offers a high degree of accuracy. This type of unit is mounted axially through the cylinder closed head with the probe extending into a clearance in the piston rod.

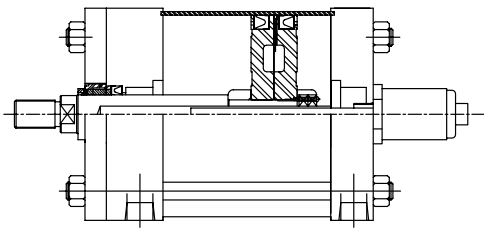

Linearity:  $\pm 0.02\%$  or better  
Repeatability:  $\pm 0.001\%$  or 0.0001" of full stroke, whichever is greater  
Control Interface: Digital or Analog output  
Approvals: UL and CE

Various models and protocols are available.

---

#### SERVO-POSITIONING SELF-LUBRICATING AIR CYLINDER

The Lehigh Positioning Cylinder is an air cylinder directly coupled to a force-balance, servo-type positioner. This combination provides a means of controlling the stroke of the piston rod to any desired length up to full stroke. The stroke control, by a remote pressure transmitter, is repeatable and infinitely variable.

This air cylinder assembly provides a precise method for creating and controlling forces by the plant operator or process transmitter located at some distance from the output device. It can develop long power strokes and may be controlled to any point in its travel.

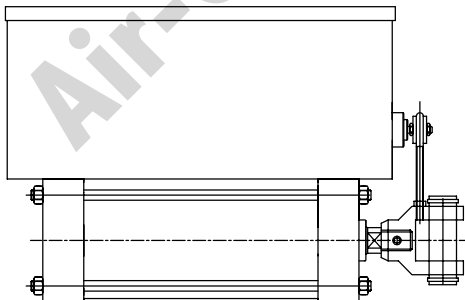

Applications include:

- ✓ Control of damper and louvre openings
- ✓ Regulating gates, shutters and doors
- ✓ Lifting loads to exact position
- ✓ Positioning slides on automated equipment
- ✓ Modulating valves

Various models and protocols are available.

---

Ordering: Contact Lehigh sales and engineering for application assistance to define ordering information.  
Specifications are subject to change without notice

# POSITION SENSING CYLINDERS

## SERVO-POSITIONING (Cont.)

### SERVO-POSITIONING SELF-LUBRICATING AIR CYLINDER (Cont.)

The Lehigh Positioning Cylinder features Lehigh's Miracalube® self-lubrication system (see page 4). The cylinder is rated for dry air and will give quick start-up operation, whether frequently used or not. It operates on pneumatic service from 25 to 150 PSI and seal temperatures to 165°F. The cylinders are from 2" to 8" diameter bore and are supplied with NFPA standard mounting styles.

The Positioning Cylinder operates on the same principles as the typical valve positioner widely used in the process industries. A precisely regulated air pressure known as "instrument air" is piped to the Positioner. The pressure transmitter for this air supply is actually a precision regulator with an adjustable output of 3 to 15 PSI.

(This device is not part of the Positioning Cylinder.) In general, when the Positioning Cylinder receives a change in signal pressure it diverts the supply air

precision regulator with an adjustable output of 3 to 15 PSI. (This device is not part of the Positioning Cylinder to one side or the other of the cylinder piston, thereby responding in stroke length proportional to the change in signal pressure.

Specifically, the instrument air pressurizes a diaphragm holding the inner end of a long spring. When the instrument air pressure changes, the diaphragm moves slightly, thus changing the air flow through a small internal nozzle. This change causes an internal pilot valve to shift, thus introducing supply air to one side of the main cylinder piston. The differential pressure moves the piston rod which extends the spring, pulling the diaphragm back into its neutral position. The unbalance of the valve is nullified, the supply air is equalized on both sides of the piston and the system comes to rest.

### POSITIONER ASSEMBLY DIMENSIONS

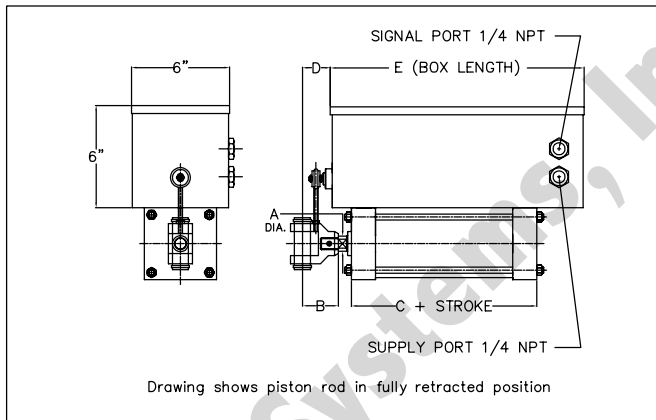

JHD	BORE SIZE	A	B	C	D
20	2	5/8	1 1/2	4 + STROKE	2 1/4
25	2 1/2	5/8	1 1/2	4 1/8 + STROKE	2 1/4
32	3 1/4	1	2 3/8	4 7/8 + STROKE	3 1/4
40	4	1	2 3/8	4 7/8 + STROKE	3 1/4
50	5	1	2 3/8	5 1/8 + STROKE	3 1/4
60	6	1 3/8	3 1/8	5 3/4 + STROKE	4 1/8
80	8	1 3/8	3 1/8	5 7/8 + STROKE	4 1/8

JHD	E ( BOX LENGTH)				
	TO 3" STROKE	OVER 3" TO 6" STROKE	OVER 6" TO 9" STROKE	OVER 9" TO 15" STROKE	OVER 15" TO 18" STROKE
20	12	18	24	30	36
25	12	18	24	30	36
32	12	18	24	30	36
40	12	18	24	30	36
50	12	18	24	30	36
60	12	18	24	30	36
80	12	18	24	30	36

### APPLICATION AND NOTES

1. Specify whether piston rod is to extend or retract as the transmitter pressure is increased.
2. Supply with clean air free of oil and moisture not exceeding 150PSI.
3. Cylinder assembly is Lehigh JHD series heavy duty air cylinder with the unique Miracalube® self-lubrication system. Refer to the NFPA standard mounting styles on pages 14-28 for cylinder dimensions on bore sizes from 2" to 8".
4. Cylinder bore sizes are from 2" to 8" diameter. Strokes are to 18" or more. Because of the forces required in balancing the piston, bore sizes should be sized well above the theoretical rating.
5. Positioner assembly is a commercial unit adapted by Lehigh to this application. The usual input range is from 3 to 15 PSI or 4-20 mA, but other instrument ranges can be designed for. Typical configurations supplied by Lehigh in this design have included Moore, Accord and Fisher positioner controls.





## BOOSTERS, INTENSIFIERS, AIR-OIL TANKS

### DESIGNING WITH BOOSTERS: AIR-TO-OIL and OIL-TO-OIL

The terms BOOSTER and INTENSIFIER are used interchangeably to describe these practical devices that typically multiply standard shop air into higher hydraulic pressure (air-to-oil), although hydraulic fluid may also be the input medium (oil-to-oil). INTENSIFIERS tend to describe those products that provide very high pressure ratios. BOOSTERS generally provide lower pressure ratings and higher volume.

There are two basic styles of BOOSTERS and INTENSIFIERS. They are the "single" and the "dual" pressure styles. The SINGLE pressure device increases the pressure in the entire non-obstructed circuit. The DUAL pressure device increases the pressure only in the portion of the circuit after the high pressure output port.

### BOOSTER AND INTENSIFIER SELECTION

Proper selection of a booster or intensifier requires the following information:

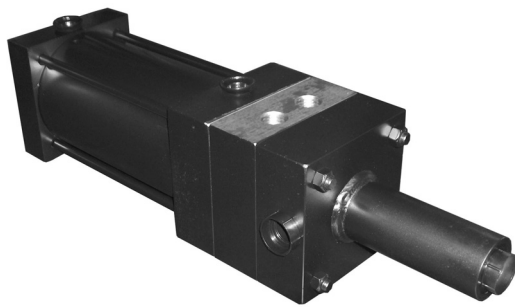

1. The input air (fluid) pressure
2. The desired output pressure
3. The bore and stroke of the high pressure cylinder in the application
4. The desired output force from the high pressure cylinder
5. A sketch of the fluid power circuit (see page 48 for examples)
6. The type of line conductors and fitting connectors used in the circuit
7. How fast the system must operate (cycles per minute)
8. Booster or intensifier mounting style
9. General description of the application and environment (temperature, wash down, etc.)

### SELECTION FORMULAS

Using the above information, calculate the required values:

$$\frac{\text{HIGH PRESS. CYL. FORCE}}{\text{HIGH PRESS. CYL. AREA}} = \text{OUTPUT PRESSURE}$$

$$\frac{\text{OUTPUT PRESSURE X 1.05}}{\text{INPUT PRESSURE X .8}} = \text{PRESSURE RATIO}$$

$$\text{HIGH PRESSURE CYLINDER STROKE X HIGH PRESSURE CYLINDER AREA} = \text{HIGH PRESSURE CYLINDER VOLUME}$$

$$\frac{\text{HIGH PRESS. CYL. VOLUME}}{\text{RAM ROD AREA X .95}} = \text{MINIMUM STROKE LENGTH}$$

$$\text{MINIMUM STROKE LENGTH} + .25 = \text{EFFECTIVE STROKE LENGTH (ROUND UP TO NEAREST .25 INCH)}$$

The .95 and 1.05 multipliers allow for friction and expansion in the hydraulic system. The .8 multiplier allows for normal variations in air line pressure. These values are general guidelines and must be adjusted accordingly.



## BOOSTERS, INTENSIFIERS, AIR-OIL TANKS (Cont.)

### SAMPLE CALCULATION: BOOSTER / INTENSIFIER SIZING

Assume a 2-1/2" dia. bore cylinder with 6" stroke. The cylinder must push 10,000 pounds for .250 inches. The cylinder must extend and retract on pressurized air or oil at 100 PSI.

What size intensifier is required?

What size air-oil tank?

$\frac{\text{HIGH PRESS. CYL. FORCE}}{\text{HIGH PRESS. CYL. AREA}} = \text{OUTPUT PRESSURE}$	$\frac{10,000 \text{ POUNDS}}{2.5^2 \times .7854} = 2,037 \text{ PSIG}$
$\frac{\text{OUTPUT PRESSURE} \times 1.05}{\text{INPUT PRESSURE} \times .8} = \text{PRESSURE RATIO}$	$\frac{2,037 \text{ PSIG} \times 1.05}{(100 \text{ PSIG} \times .8)} = 26.74$

HIGH PRESSURE CYLINDER STROKE X HIGH PRESSURE CYLINDER AREA = HIGH PRESSURE CYLINDER VOLUME  
The high pressure cylinder stroke is .250 x .490 square inches = 1.23 cubic inches

$\frac{\text{HIGH PRESS. CYL. VOLUME}}{\text{RAM ROD AREA} \times .95} = \text{MINIMUM STROKE LENGTH}$	$\frac{1.23 \text{ Cubic Inch}}{.31 \text{ (from Ratio Chart below)} \times .95} = 4.17 \text{ Inches}$
--	---

MINIMUM STROKE LENGTH + .25 = EFFECTIVE STROKE LENGTH (ROUND UP TO NEAREST .25 INCH)  
The minimum stroke length 4.17 plus .25 = 4.42 inch effective stroke, rounding up to 4.5 inches total stroke

The following intensifiers can be used for this sample application. Choose among the three by the space available for the intensifier. Consult Lehigh for additional application assistance. (See page 48 for air-oil tank selection.)

3-1/4" dia. bore x 5/8" ram dia. x 4-1/2" stroke

4" dia. bore x 5/8" ram dia. x 4-1/2" stroke

6" dia. bore x 1" ram dia. x 2" stroke

RAM ROD DIA.	RAM ROD AREA (SQ. IN.)	PRESSURE RATIOS (BORE AREA / RAM AREA)							
		BORE SIZE (BORE AREA)							
		3 1/4 (8.29 SQ. IN.)	4.0 (12.57 SQ. IN.)	5.0 (19.64 SQ. IN.)	6.0 (28.27 SQ. IN.)	8.0 (50.27 SQ. IN.)	10.0 (78.54 SQ. IN.)	12.0 (113.10 SQ. IN.)	
5/8	.31	26.74	40.55	63.35	---	---	---	---	
1	.79	10.49	15.91	24.86	35.78	63.63	---	---	
1 3/8	1.49	5.56	8.44	13.18	18.97	33.75	52.71	---	
1 3/4	2.41	3.44	5.22	8.15	11.73	20.86	32.59	46.93	
2	3.14	2.64	4.00	6.25	9.00	16.00	25.01	36.02	
2 1/2	4.91	---	---	---	5.76	10.24	15.99	23.03	
3	7.06	---	---	---	---	---	11.12	16.02	
3 1/2	9.62	---	---	---	---	---	---	11.76	

## BOOSTERS, INTENSIFIERS, AIR-OIL TANKS (Cont.)

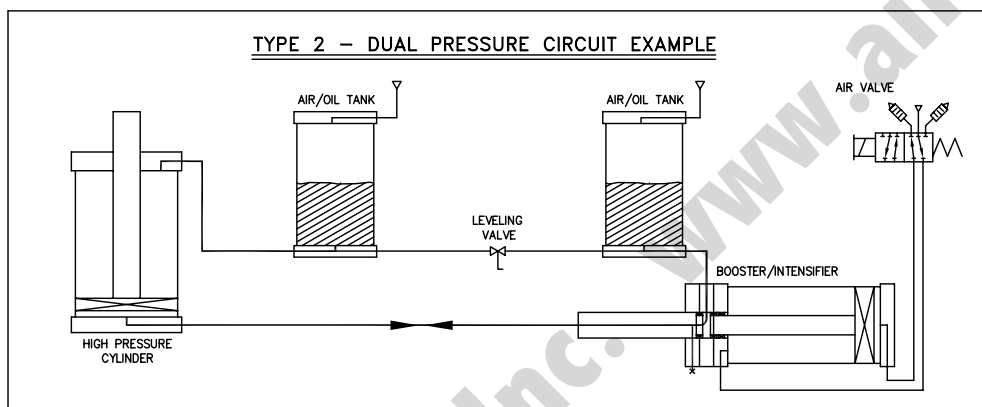
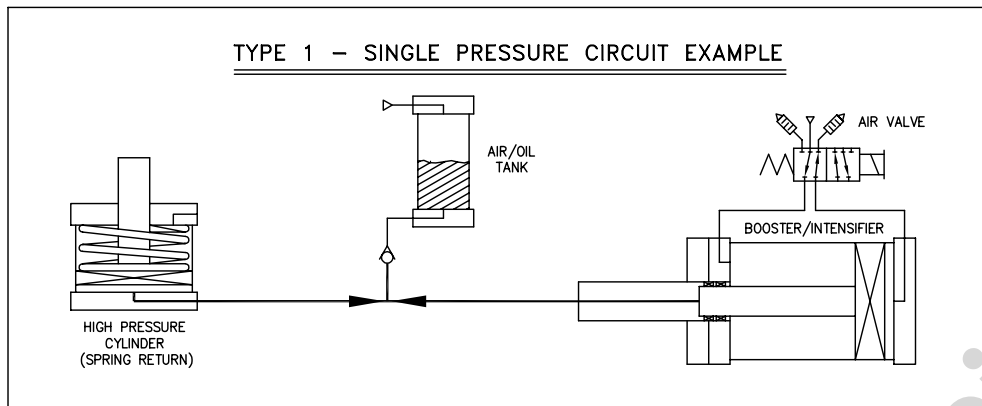

### SAMPLE CALCULATION: AIR-OIL TANK SIZING

$$\frac{\text{BORE}^2 \times .7854 \times \text{STROKE} \times \text{TANK FACTOR}^*}{\text{TANK VOLUME PER INCH}} = \text{MINIMUM TANK LENGTH} \quad \frac{2.5^2 \times .7854 \times 6 \times 2.5}{8.3 \text{ (from chart on p. 50)}} = 8.87 \text{ INCHES}$$

(Use the bore diameter of the working cylinder for  $\text{BORE}^2$ . Use the stroke of the working cylinder for  $\text{STROKE}$ . The  $\text{TANK VOLUME PER INCH}$  is from the chart on p.50. The volume selected for the formula yields the minimum tank length for the associated tank bore.)

ROUND THE TANK LENGTH UPWARD TO THE NEAREST WHOLE INCH: 8.87 rounds to 9.0 inches long

\*The "Tank Factor" varies with tank length, but is generally between 2 and 3 depending on the tank application.

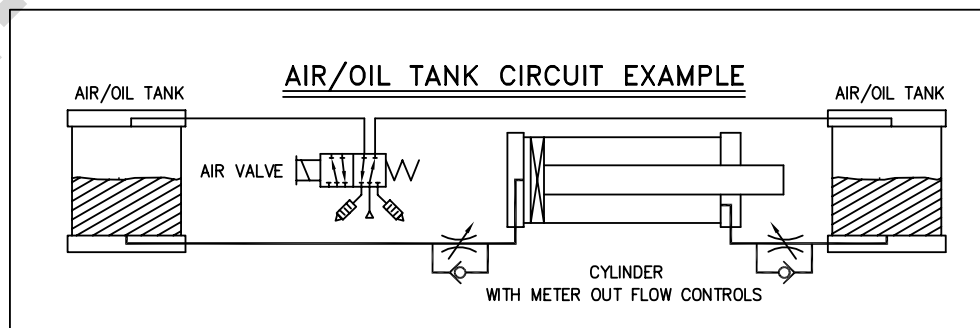

**Note:** Sample circuits are for concept illustration purposes only. Additional safety devices, controls and lockouts are required for safe operation.

# BOOSTERS, INTENSIFIERS, AIR-OIL TANKS (Cont.)

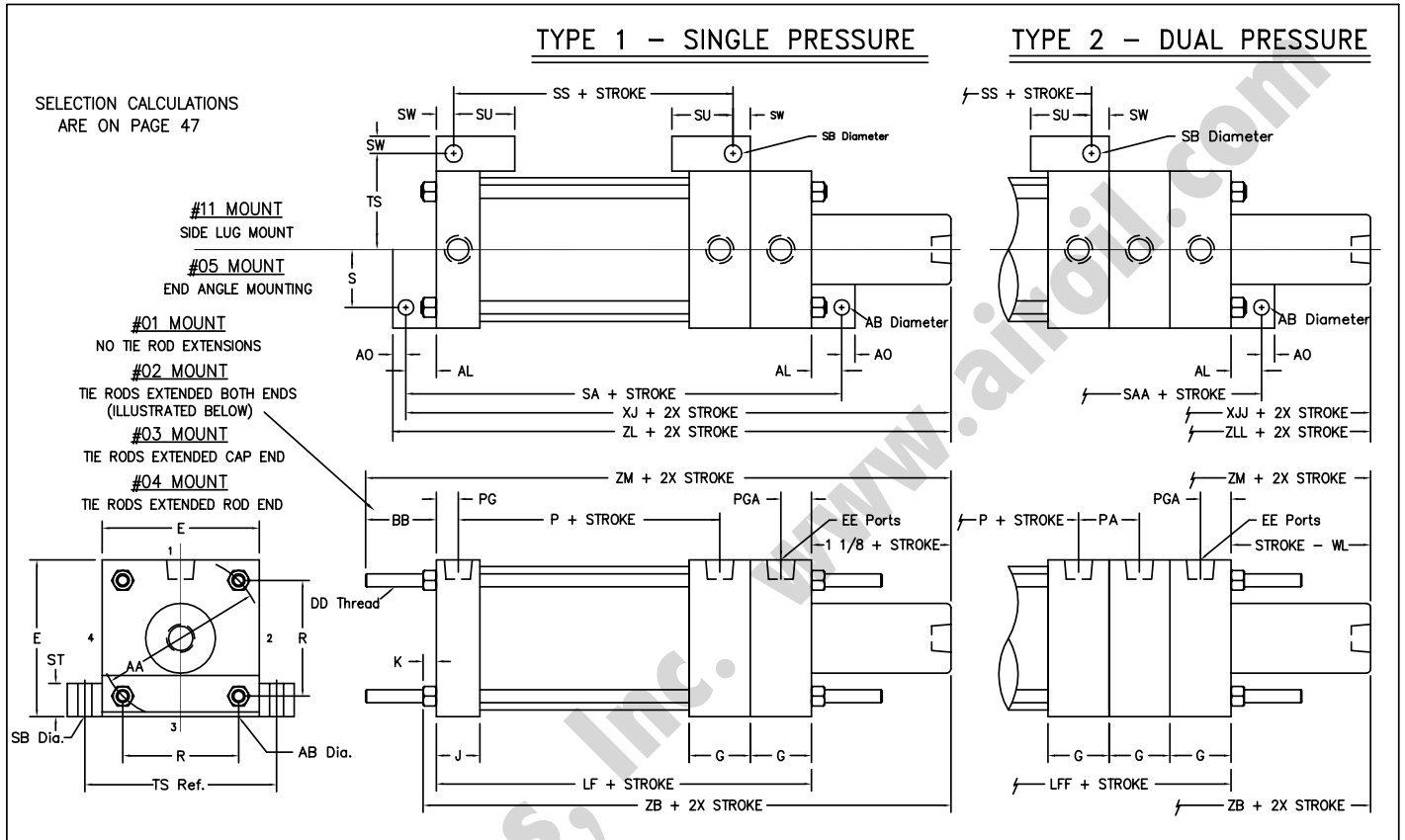

## ENVELOPE AND MOUNTING DIMENSIONS

BORE	AA	AB	AL	AO	BB	DD	E	EE NPT	G	J	K	ADD STROKE					
												LF	LFF	P	SA	SAA	SS
3 1/4	3.90	9/16	1 1/4	1/2	1 3/8	3/8-24	3 3/4	1/2	1 3/4	1 1/4	3/8	6	7 3/4	2 5/8	8 1/2	10 1/4	3 1/4
4	4.70	9/16	1 1/4	1/2	1 3/8	3/8-24	4 1/2	1/2	1 3/4	1 1/4	3/8	6	7 3/4	2 5/8	8 1/2	10 1/4	3 1/4
5	5.80	11/16	1 3/8	5/8	1 13/16	1/2-20	5 1/2	1/2	1 3/4	1 1/4	7/16	6 1/4	8	2 7/8	9	10 3/4	3 1/8
6	6.90	13/16	1 3/8	5/8	1 13/16	1/2-20	6 1/2	3/4	2	1 1/2	7/16	7	9	3 1/8	9 3/4	11 3/4	3 5/8
8	9.10	13/16	1 13/16	11/16	2 5/16	5/8-18	8 1/2	3/4	2	1 1/2	9/16	7 1/8	9 1/8	3 1/4	10 3/4	12 3/4	3 3/4
10	11.20	1 1/16	2 1/8	7/8	2 11/16	3/4-16	10 5/8	1	2 1/4	2	11/16	8 5/8	10 7/8	4 1/8	12 7/8	15 1/8	4 5/8
12	13.30	1 1/16	2 1/8	7/8	2 11/16	3/4-16	12 3/4	1	2 1/4	2	11/16	9 1/8	11 3/8	4 5/8	13 3/8	15 5/8	5 1/8

BORE	R	PA	PG	PGA	S	SB	ST	SU	SW	TS	STROKE MINUS WL	ADD 2X STROKE					
												XJ	XJJ	ZB	ZL	ZLL	ZM
3 1/4	2.76	2 1/8	9/16	11/16	2 3/4	9/16	3/4	1 1/4	1/2	4 3/4	5/8	8 3/8	8	7 1/2	8 7/8	8 3/8	8 1/2
4	3.32	2 1/8	9/16	11/16	3 1/2	9/16	3/4	1 1/4	1/2	5 1/2	5/8	8 3/8	8 1/8	7 1/2	8 7/8	8 1/2	8 1/2
5	4.10	2 1/8	9/16	11/16	4 1/4	13/16	1	1 9/16	11/16	6 7/8	5/8	8 3/4	8 7/16	7 13/16	9 3/8	8 15/16	9 3/16
6	4.88	2 3/8	11/16	13/16	5 1/4	13/16	1	1 9/16	11/16	7 7/8	7/8	9 1/2	9 1/8	8 9/16	10 1/8	9 5/8	9 15/16
8	6.44	2 3/8	11/16	13/16	7 1/8	13/16	1	1 9/16	11/16	9 7/8	7/8	10 1/16	9 3/8	8 13/16	10 3/4	10	10 9/16
10	7.92	2 1/2	1	1	8 7/8	1 1/16	1 1/4	2	7/8	12 3/8	1 1/8	11 7/8	11 1/16	10 7/16	12 3/4	11 11/16	12 7/16
12	9.40	2 1/2	1	1	11	1 1/16	1 1/4	2	7/8	14 1/2	1 1/8	12 3/8	11 9/16	10 15/16	13 1/4	12 3/16	12 15/16

NPT PORTS FURNISHED UNLESS OTHERWISE SPECIFIED

# BOOSTERS, INTENSIFIERS, AIR-OIL TANKS (Cont.)

## AIR - OIL TANKS

TYPE 1 = TRANSLUCENT TUBE

TYPE 2 = OPAQUE TUBE & SIGHT TUBE

SELECTION CALCULATIONS ON PAGE 48

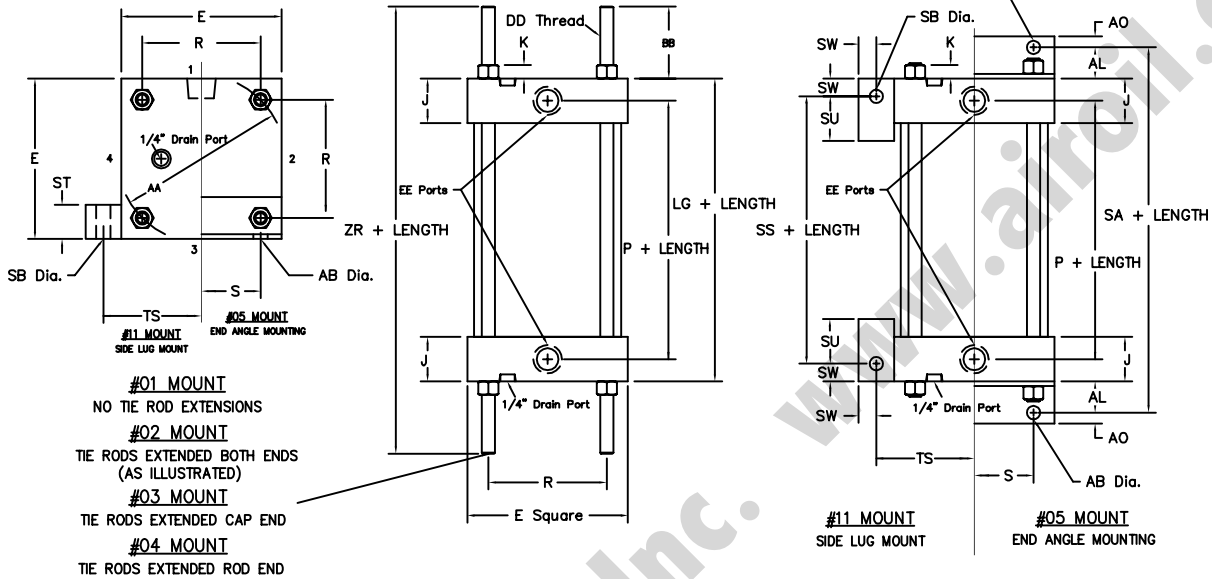

MATERIALS OF CONSTRUCTION TYPICALLY ARE STEEL HEADS, TIE RODS AND MOUNTS, WITH TRANSLUCENT PLASTIC TUBES. OPTIONS INCLUDE METALLIC AND NON-METALLIC TUBES, SIGHT GLASSES, ADDITIONAL PORTS, ALL STAINLESS STEEL, COMPOSITE MATERIALS, GLASS TUBES, ETC. PLEASE CONSULT THE FACTORY FOR MATERIALS COMPATIBILITY WITH BOTH THE STANDARD TANKS AND SPECIAL APPLICATIONS.

## ENVELOPE AND MOUNTING DIMENSIONS

BORE	VOL. PER IN.	AA	AB	AL	AO	BB	DD	E	EE NPT	J	K	PG
3 1/4	8.29 CU. IN.	3.90	9/16	1 1/4	1/2	1 3/8	3/8-24	3 3/4	1/2	1 1/4	3/8	9/16
4	12.56 CU. IN.	4.70	9/16	1 1/4	1/2	1 3/8	3/8-24	4 1/2	1/2	1 1/4	3/8	9/16
5	19.63 CU. IN.	5.80	11/16	1 3/8	5/8	1 13/16	1/2-20	5 1/2	1/2	1 1/4	7/16	9/16
6	28.27 CU. IN.	6.90	13/16	1 3/8	5/8	1 13/16	1/2-20	6 1/2	3/4	1 1/2	7/16	11/16
8	50.26 CU. IN.	9.10	13/16	1 13/16	11/16	2 5/16	5/8-18	8 1/2	3/4	1 1/2	9/16	11/16

BORE	R	S	SB	ST	SU	SW	TS	ADD TANK LENGTH				
								LG	P	SA	SS	ZR
3 1/4	2.76	2 3/4	9/16	3/4	1 1/4	1/2	4 3/4	2 1/2	1 3/8	5	1 1/2	5 1/4
4	3.32	3 1/2	9/16	3/4	1 1/4	1/2	5 1/2	2 1/2	1 3/8	5	1 1/2	5 1/4
5	4.10	4 1/4	13/16	1	1 9/16	11/16	6 7/8	2 1/2	1 3/8	5 1/4	1 1/8	6 1/8
6	4.88	5 1/4	13/16	1	1 9/16	11/16	7 7/8	3	1 5/8	5 3/4	1 5/8	6 5/8
8	6.44	7 1/8	13/16	1	1 9/16	11/16	9 7/8	3	1 5/8	6 5/8	1 5/8	7 5/8

NPT PORTS FURNISHED UNLESS OTHERWISE SPECIFIED

# BOOSTERS, INTENSIFIERS, AIR-OIL TANKS (Cont.)

## ORDERING INFORMATION

### BOOSTERS & INTENSIFIERS

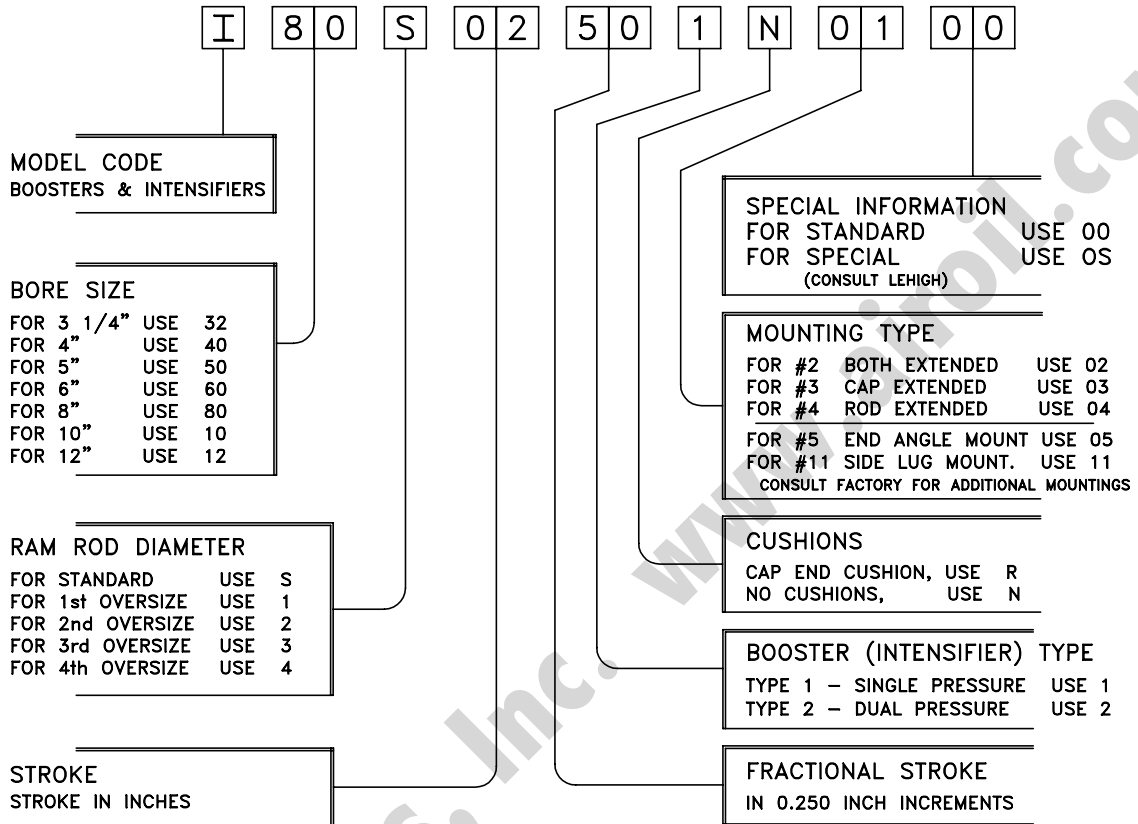

### AIR / OIL TANKS

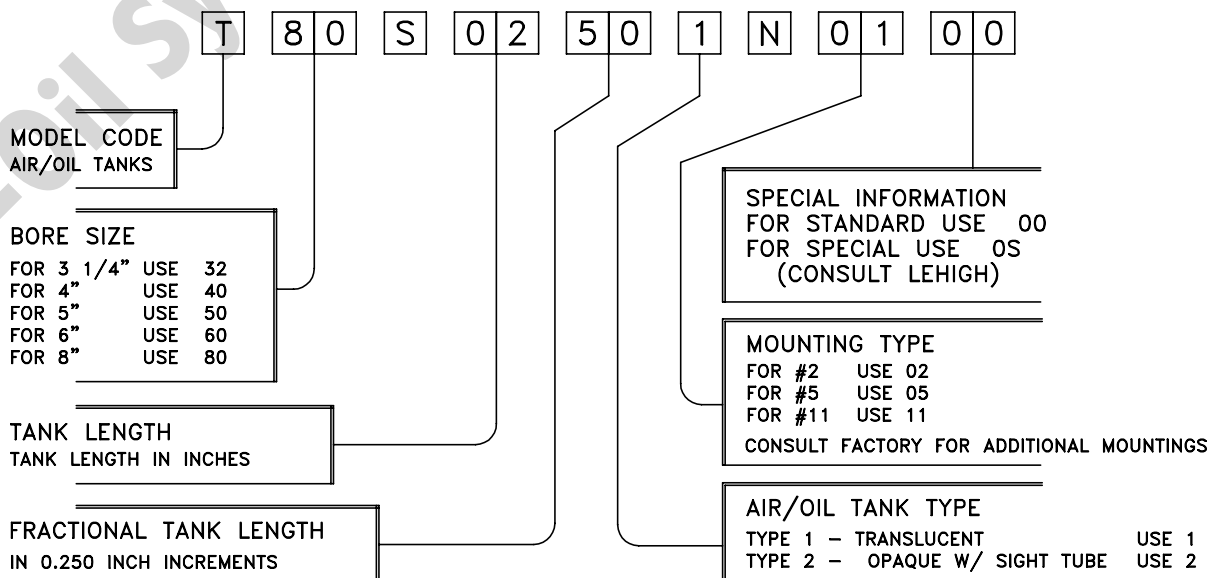



# FLANGED ROD END AND COUPLING

## TYPE F FLANGED ROD END

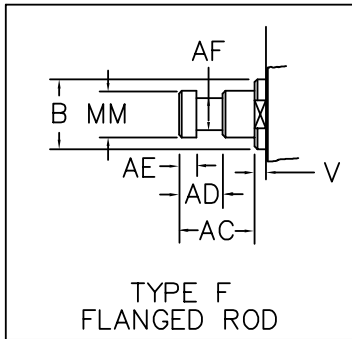

### DIMENSIONS

ROD DIA. MM	AC	AD	AE +.000 - .003	AF DIA.	B DIA. +.000 - .002
5/8	1 1/8	5/8	.250	3/8	1,124
1	1 5/8	15/16	.375	11/16	1,499
1 3/8	1 3/4	1 1/16	.375	7/8	1,999
1 3/4	2	1 5/16	.500	1 1/8	2,374
2	2 5/8	1 11/16	.625	1 3/8	2,624
2 1/2	3 1/4	1 15/16	.750	1 3/4	3,124
3	3 5/8	2 7/16	.875	2 1/4	3,749
3 1/2	4 3/8	2 11/16	1.000	2 1/2	4,249
4	4 1/2	2 11/16	1.000	3	4,749
4 1/2	5 1/4	3 3/16	1.500	3 1/2	5,249
5	5 3/8	3 3/16	1.500	3 7/8	5,749
5 1/2	6 1/4	3 15/16	1.875	4 3/8	6,249
7	6 1/2	4 1/16	2.000	5 3/4	7,999
8	6 1/2	4 1/16	2.000	6 1/2	8,999
8 1/2	6 1/2	4 1/16	2.000	6 1/2	9,499
10	7 1/4	4 5/8	2.375	8	10,999

Note: "V" dimension varies per bore size. See data in mounting dimension tables of the respective cylinder mounts.

## FLANGED ROD END COUPLING

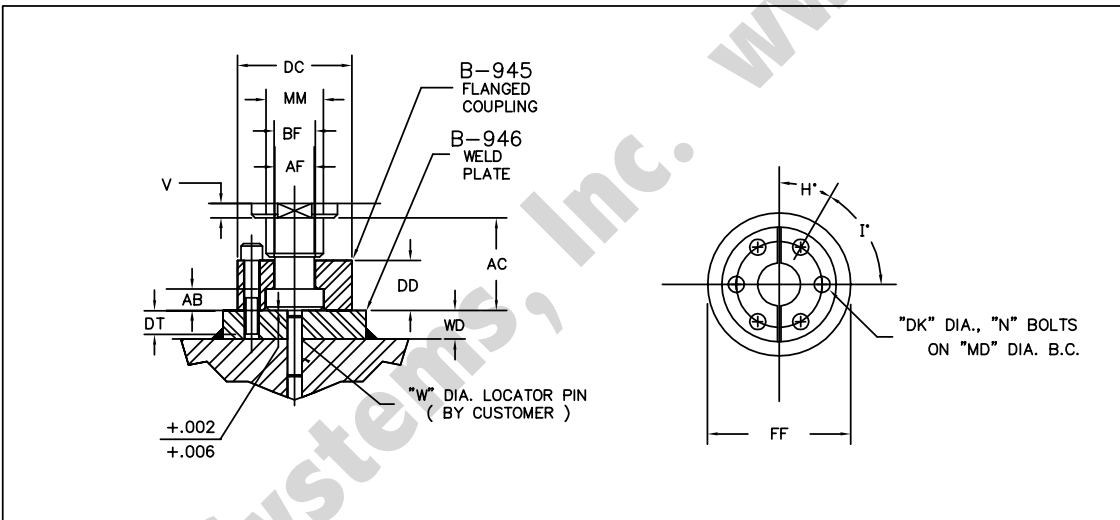

### DIMENSIONS

PART NO.	ROD DIA. MM	AB .002 - .000	AF DIA.	BF DIA.	DC DIA.	DD	DK THREAD	DT	FF DIA.	H DEGREE	I DEGREE	MD DIA.	N	WELD PLATE NO.	W DIA.	WD	BOLT TORQUE FT. LBS
B-945-1	5/8	.250	3/8	13/32	1 1/2	9/16	#10-24	3/8	2	45	90	1.12	4	B-946-1	1/4	1/2	5
B-945-2	1	.375	11/16	3/4	2	7/8	1/4-20	3/8	2 1/2	30	60	1.50	6	B-946-2	1/4	1/2	12
B-945-3	1 3/8	.375	7/8	15/16	2 1/2	1	5/16-18	1/2	3	30	60	2.00	6	B-946-3	1/4	5/8	25
B-945-4	1 3/4	.500	1 1/8	1 3/16	3	1 1/4	5/16-18	1/2	4	22 1/2	45	2.38	8	B-946-4	1/4	5/8	25
B-945-5	2	.625	1 3/8	1 7/16	3 1/2	1 5/8	3/8-16	5/8	4	15	30	2.69	12	B-946-5	3/8	3/4	50
B-945-6	2 1/2	.750	1 3/4	1 7/8	4	1 7/8	3/8-16	5/8	4 1/2	15	30	3.19	12	B-946-6	3/8	3/4	50
B-945-7	3	.875	2 1/4	2 3/8	5	2 3/8	1/2-13	7/8	5 1/2	15	30	4.00	12	B-946-7	3/8	1	125
B-945-8	3 1/2	1.000	2 1/2	2 5/8	5 7/8	2 5/8	5/8-11	7/8	7	15	30	4.69	12	B-946-8	3/8	1	245
B-945-9	4	1.000	3	3 1/8	6 3/8	2 5/8	5/8-11	7/8	7	15	30	5.19	12	B-946-9	3/8	1	245
B-945-10	4 1/2	1.500	3 1/2	3 5/8	6 7/8	3 1/8	5/8-11	7/8	8	15	30	5.69	12	B-946-10	3/8	1	245
B-945-11	5	1.500	3 7/8	4	7 3/8	3 1/8	5/8-11	7/8	8	15	30	6.19	12	B-946-11	3/8	1	245
B-945-12	5 1/2	1.875	4 3/8	4 1/2	8 1/4	3 7/8	3/4-10	1 1/8	9	15	30	6.88	12	B-946-12	3/8	1 1/4	425
B-945-13	7	2.000	5 3/4	5 15/16	10 3/8	4	1-8	1 1/2	11	15	30	8.75	12	B-946-13	1/2	1 3/4	1090
B-945-14	8	2.000	6 1/2	6 11/16	11 3/8	4	1-8	1 1/2	12	11 1/4	22 1/2	9.75	16	B-946-14	1/2	2	1090
B-945-14	8 1/2	2.000	6 1/2	6 11/16	11 3/8	4	1-8	1 1/2	12	11 1/4	22 1/2	10.25	16	B-946-14	1/2	2	1090
B-945-15	10	2.375	8	8 1/4	14 1/8	4 1/2	1 1/4-7	2	15	11 1/4	22 1/2	12.12	16	B-946-15	1/2	2 1/2	2180





## SELF-ALIGNING ROD COUPLERS

This accessory is used when precise stroke alignment of the installed cylinder is questionable. Installation is simplified, assembly costs are reduced, and cylinder life is extended because wear is reduced on rod bearing and seals.

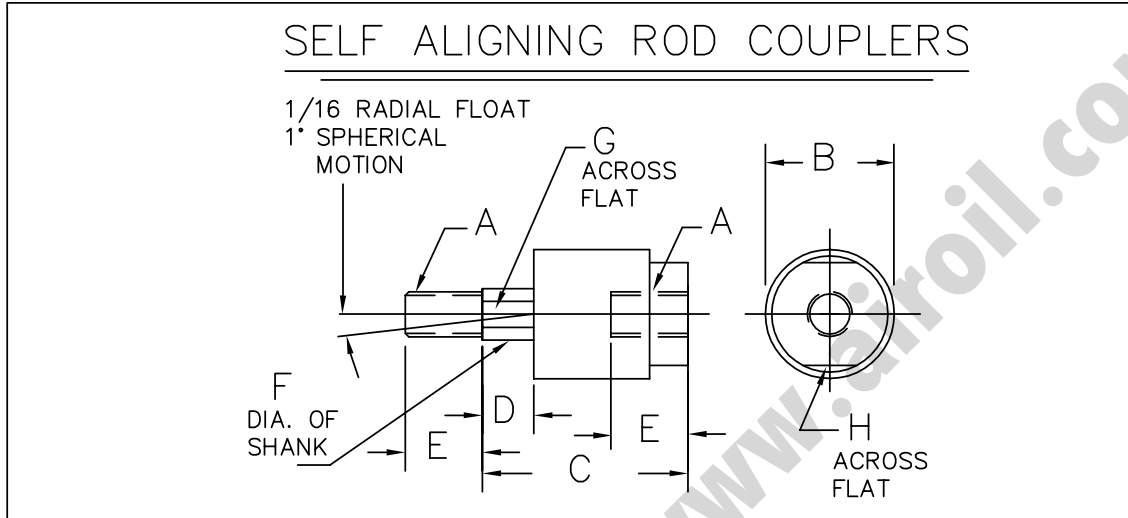

### DIMENSIONS

MODEL NO.	A	B DIA.	C	D	E	F DIA.	G	H	MAX # PULL AT YIELD
B-947-1	1/4-28	7/8	1 1/4	1/4	5/8	.245	3/16	13/16	4,000#
B-947-2	5/16-24	7/8	1 1/4	1/4	5/8	.308	1/4	13/16	4,000#
B-947-3	3/8-24	7/8	1 1/4	1/4	5/8	.370	5/16	13/16	5,000#
B-947-4	7/16-20	1 1/4	2	1/2	3/4	.62	9/16	1 1/8	10,000#
B-947-5	1/2-20	1 1/4	2	1/2	3/4	.62	9/16	1 1/8	14,000#
B-947-6	5/8-18	1 1/4	2	1/2	3/4	.62	1/2	1 1/8	14,000#
B-947-7	3/4-16	1 3/4	2 5/16	1/2	1 1/8	.97	7/8	1 1/2	34,000#
B-947-8	7/8-14	1 3/4	2 5/16	1/2	1 1/8	.97	7/8	1 1/2	34,000#
B-947-9	1-14	2 1/2	2 15/16	1/2	1 5/8	1.38	1 1/4	2 1/4	64,000#
B-947-10	1 1/4-12	2 1/2	2 15/16	1/2	1 5/8	1.38	1 1/4	2 1/4	64,000#
B-947-11	1 3/8-12	2 1/2	2 15/16	1/2	1 5/8	1.38	1 1/4	2 1/4	64,000#
B-947-12	1 1/2-12	3 1/4	4 3/8	13/16	2 1/4	1.75	1 1/2	3	120,000#
B-947-13	1 3/4-12	3 1/4	4 3/8	13/16	2 1/4	1.75	1 1/2	3	120,000#
B-947-14	1 7/8-12	3 3/4	5 7/16	11/16	3	2.25	1 7/8	3 1/2	240,000#
B-947-15	2-12	3 3/4	5 7/16	11/16	3	2.25	1 7/8	3 1/2	240,000#
B-947-16	2 1/4-12	6 3/4	6 3/8	N/A	3 1/2	2.75	2 3/8	2 7/8	397,000#
B-947-17	2 1/2-12	7	6 1/2	N/A	3 1/2	3.25	2 7/8	3 3/8	495,000#
B-947-18	2 3/4-12	7	6 1/2	N/A	3/12	3.25	2 7/8	3 3/8	603,800#
B-947-19	3-12	7	6 1/2	N/A	3 1/2	3.25	2 7/8	3 3/8	723,400#
B-947-20	3 1/4-12	9 1/4	8 1/2	N/A	4 1/2	4.00	3 3/8	4 1/2	853,800#
B-947-21	4 1/4-12	12 7/8	11 1/4	N/A	4 1/2	5.50	4 7/8	7	1,483,400#

N/A = NOT APPLICABLE TO THIS SIZE



# CAP AND ROD END MOUNTING ACCESSORIES

## STANDARD AND STAINLESS STEEL

### ROD END ACCESSORIES

ROD THREAD SIZE KK	ROD CLEVIS	ROD EYE	EYE BRACKET	PIVOT PIN	CLEVIS BRACKET
7/16-20	MACCL01	MACRE01	MACEB01	MACPN01	MACCB01
3/4-16	MACCL02	MACRE02	MACEB02	MACPN02	MACCB02
1-14	MACCL03	MACRE03	MACEB03	MACPN03	MACCB03
1 1/4-12	MACCL04	MACRE04	MACEB04	MACPN04	MACCB04
1 1/2-12	MACCL05	MACRE05	MACEB05	MACPN05	MACCB05
1 7/8-12	MACCL06	MACRE06	MACEB06	MACPN06	MACCB06
2 1/4-12	MACCL07	MACRE07	MACEB07	MACPN07	MACCB07
2 1/2-12	MACCL08	MACRE08	MACEB08	MACPN08	MACCB08
3 1/4-12	MACCL09	MACRE09	MACEB09	MACPN09	MACCB09
4-12	MACCL10	MACRE10	MACEB10	MACPN10	MACCB10

1. Rod Clevises and Rod Eyes are stocked to fit the standard "KK" rod thread (style A, Small Male). The "CC" thread for Type D (Intermediate Male) can be supplied on special order.
2. Rod Clevises are supplied with Pivot Pins as standard. Pivot Pins are not supplied with Rod Eyes or Eye Brackets. They must be ordered as separate items if desired.

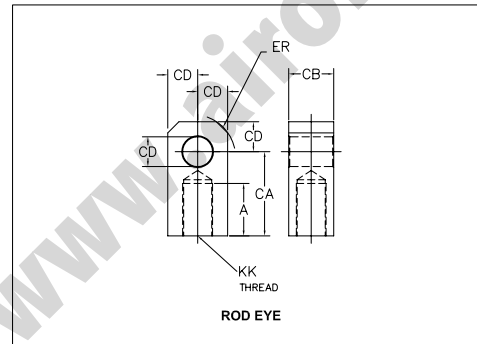
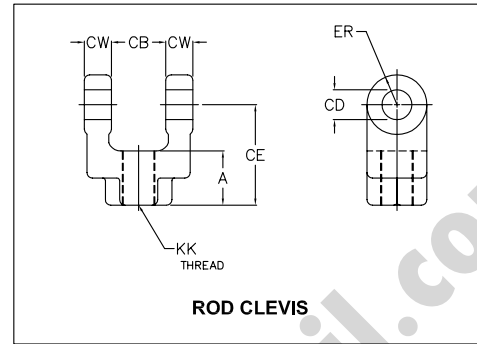

### CAP END ACCESSORIES

CYLINDER BORE	EYE BRACKET	PIVOT PIN	CLEVIS BRACKET
1 1/2, 2, & 2 1/2	MACEB01	MACPN01	MACCB01
3 1/4, 4, & 5	MACEB02	MACPN02	MACCB02
6 & 8	MACEB03	MACPN03	MACCB03
10	MACEB04	MACPN04	MACCB04
12	MACEB05	MACPN05	MACCB05
14	MACEB06	MACPN06	MACCB06
16	MACEB07	MACPN07	MACCB07
18 & 20	MACEB08	MACPN08	MACCB08

1. Pivot Pins are not supplied with Eye Brackets. They must be ordered as separate items if desired.
2. Eye Brackets are designed to mate with cylinder mounting Style 8F (NFPA MP1) and Style 8D (NFPA MP2).
3. Clevis Brackets are designed to mate with cylinder mounting Style 8M (NFPA MP3) and Rod Eyes.

#### NOTE: STAINLESS STEEL

Part Numbers in the above charts are for standard Rod End and Cap End Accessories. All items are also available in **stainless steel**. For stainless steel accessories, add "S" to the end of the Part Number: e.g.; MACCL01 for standard Rod Clevis, MACCL01S for stainless steel Rod Clevis.

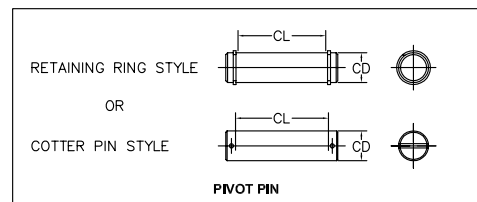
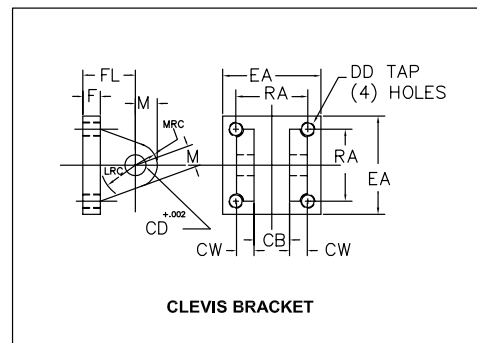
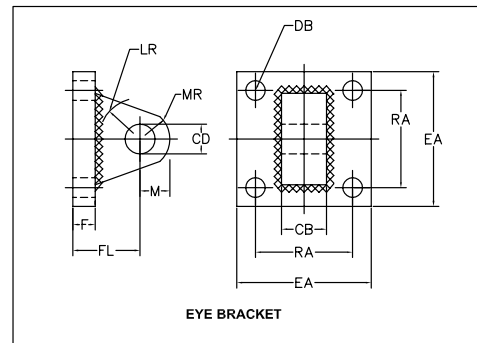

**CAP AND ROD END MOUNTING ACCESSORIES (Cont.)**  
**STANDARD AND STAINLESS STEEL**

**ROD CLEVIS PART NUMBER**

	MACCLO1	MACCLO2	MACCLO3	MACCLO4	MACCLO5	MACCLO6	MACCLO7	MACCLO8	MACCLO9	MACCLO10
<b>A</b>	3/4	1 1/8	1 5/8	2	2 1/4	3	3 1/2	3 1/2	4 1/2	5 1/2
<b>CB</b>	3/4	1 1/4	1 1/2	2	2 1/2	2 1/2	3	3	4	4 1/2
<b>CD</b>	1/2	3/4	1	1 3/8	1 3/4	2	2 1/2	3	3 1/2	4
<b>CE</b>	1 1/2	2 3/8	3 1/8	4 1/8	4 1/2	5 1/2	6 1/2	6 3/4	8 1/2	10
<b>CW</b>	1/2	5/8	3/4	1	1 1/4	1 1/4	1 1/2	1 1/2	2	2 1/4
<b>ER</b>	1/2	3/4	1	1 3/8	1 3/4	2	2 1/2	3	3 1/2	4
<b>KK</b>	7/16-20	3/4-16	1-14	1 1/4-12	1 1/2-12	1 7/8-12	2 1/4-12	2 1/2-12	3 1/4-12	4-12

**ROD EYE PART NUMBER**

	MACRE01	MACRE02	MACRE03	MACRE04	MACRE05	MACRE06	MACRE07	MACRE08	MACRE09	MACRE10
<b>A</b>	3/4	1 1/8	1 5/8	2	2 1/4	3	3 1/2	3 1/2	4 1/2	5 1/2
<b>CA</b>	1 1/2	2 1/16	2 13/16	3 7/16	4	5	5 13/16	6 1/8	7 5/8	9 1/8
<b>CB</b>	3/4	1 1/4	1 1/2	2	2 1/2	2 1/2	3	3	4	4 1/2
<b>CD</b>	1/2	3/4	1	1 3/8	1 3/4	2	2 1/2	3	3 1/2	4
<b>ER</b>	5/8	7/8	1 3/16	1 9/16	2	2 1/2	2 13/16	3 1/4	3 7/8	4 7/16
<b>KK</b>	7/16-20	3/4-16	1-14	1 1/4-12	1 1/2-12	1 7/8-12	2 1/4-12	2 1/2-12	3 1/4-12	4-12

**EYE BRACKET PART NUMBER (MACEB) OR CLEVIS BRACKET PART NUMBER (MACCB)**

	MACCB01	MACCB02	MACCB03	MACCB04	MACCB05	MACCB06	MACCB07	MACCB08	MACCB09	MACCB10
	MACEB01	MACEB02	MACEB03	MACEB04	MACEB05	MACEB06	MACEB07	MACEB08	MACEB09	MACEB10
<b>CB</b>	3/4	1 1/4	1 1/2	2	2 1/2	2 1/2	3	3	4	4 1/2
<b>CD</b>	1/2	3/4	1	1 3/8	1 3/4	2	2 1/2	3	3 1/2	4
<b>CW</b>	1/2	5/8	3/4	1	1 1/4	1 1/4	1 1/2	1 1/2	2	2 1/4
<b>DB</b>	13/32	17/32	21/32	21/32	29/32	1 1/16	1 3/16	1 5/16	1 13/16	2 1/16
<b>DD</b>	3/8-24	1/2-20	5/8-18	5/8-18	7/8-14	1-14	1 1/8-12	1 1/4-12	1 3/4-12	2-12
<b>EA</b>	2 1/2	3 1/2	4 1/2	5	6 1/2	7 1/2	8 1/2	9 1/2	12 5/8	14 7/8
<b>F</b>	3/8	5/8	3/4	7/8	7/8	1	1	1	1 11/16	1 15/16
<b>FL</b>	1 1/8	1 7/8	2 1/4	3	3 1/8	3 1/2	4	4 1/4	5 11/16	6 7/16
<b>LR</b>	3/4	1 1/4	1 1/2	2 1/8	2 1/4	2 1/2	3	3 1/4	4	4 1/2
<b>LRC</b>	1/2	1 1/16	1 1/4	1 7/8	2	2 1/8	2 5/8	2 7/8	3 5/8	4
<b>M</b>	1/2	3/4	1	1 3/8	1 3/4	2	2 1/2	3	3 1/2	4
<b>MR</b>	9/16	7/8	1 1/4	1 5/8	2 1/8	2 7/16	3	3 1/4	3 7/8	5 1/4
<b>MRC</b>	9/16	1 1/16	1 1/8	1 3/4	1 7/8	2 1/8	2 1/2	2 3/4	3 1/2	4
<b>RA</b>	1.63	2.55	3.25	3.82	4.95	5.73	6.58	7.50	9.62	11.45

**PIVOT PIN PART NUMBER**

	MACPN01	MACPN02	MACPN03	MACPN04	MACPN05	MACPN06	MACPN07	MACPN08	MACPN09	MACPN10
<b>CD</b>	1/2	3/4	1	1 3/8	1 3/4	2	2 1/2	3	3 1/2	4
<b>CL</b>	1 3/4	2 1/2	3	4	5	5	6	6	8	9

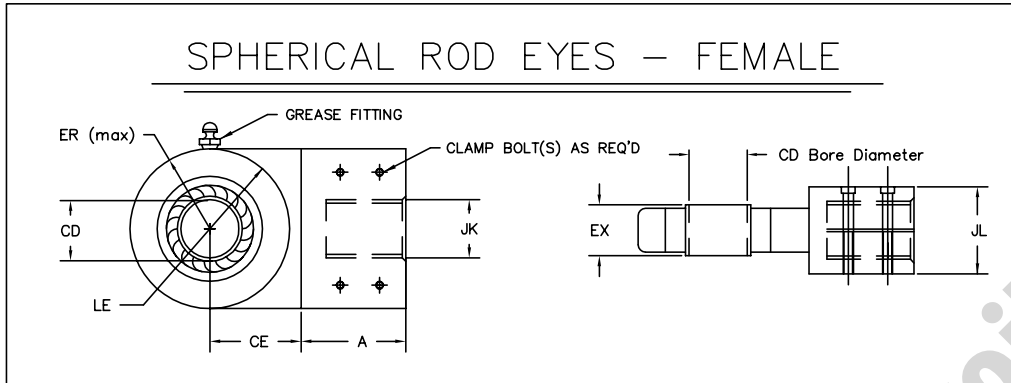

### MOUNTING DIMENSIONS

PART NO.	CD +.0000 -.0005	A	CE	EX	ER	LE	JK	JL	CLAMP BOLTS QUANTITY SIZE	MAX HYD. CYLINDER BORE & PSIG	MAX LOAD CAPACITY IN POUNDS
LSRE-05F	.5000	1 1/2	3/4	.437	1	5/8	7/16-20	1 1/4	(2) #10-32	1 1/2 @ 1,400	2,600
LSRE-07F	.7500	2	1 1/4	.656	1	1	7/16-20	1 1/4	(2) #10-32	1 1/2 @ 3,000	9,400
LSRE-08F	.7500	2	1 1/4	.656	1 1/4	1	3/4-16	2	(2) #10-32	2 @ 3,000	9,400
LSRE-10F	1.0000	2	1 1/2	.875	1 1/2	1 1/4	3/4-16	2	(2) #10-32	2 1/2 @ 3,000	16,800
LSRE-13F	1.3750	2 1/2	2 1/8	1.187	1 7/8	1 7/8	1.00-14	2	(2) #10-32	3 1/4 @ 3,000	28,600
LSRE-17F	1.7500	2 3/4	2 1/4	1.531	2 1/4	2	1 1/4-12	2 3/4	(2) 1/4-28	4 @ 3,000	43,000
LSRE-20F	2.0000	3	2 1/2	1.750	2 3/4	2 1/4	1 1/2-12	2 3/4	(2) 1/4-28	5 @ 3,000	70,000
LSRE-25F	2.5000	3 5/8	3	2.187	3 1/4	2 3/4	1 7/8-12	3	(2) 1/4-28	6 @ 3,000	85,000
LSRE-30F	3.0000	4 3/8	3 3/4	2.625	4	3 1/2	2 1/4-12	3 1/2	(4) 1/4-28	7 @ 3,000	87,700
LSRE-35F	3.5000	4 3/4	4 3/8	3.062	4 1/2	4 1/8	2 1/2-12	3 3/4	(4) 5/16-24	8 @ 3,000	119,200
LSRE-45F	4.5000	6 1/4	5 5/8	3.937	6	5 1/4	3 1/2-12	4 3/4	(4) 3/8-24	10 @ 3,000	210,500
LSRE-50F	5.0000	6 3/4	6 1/4	4.375	7	5 7/8	4.00-12	5 1/2	(4) 3/8-24	12 @ 3,000	245,500

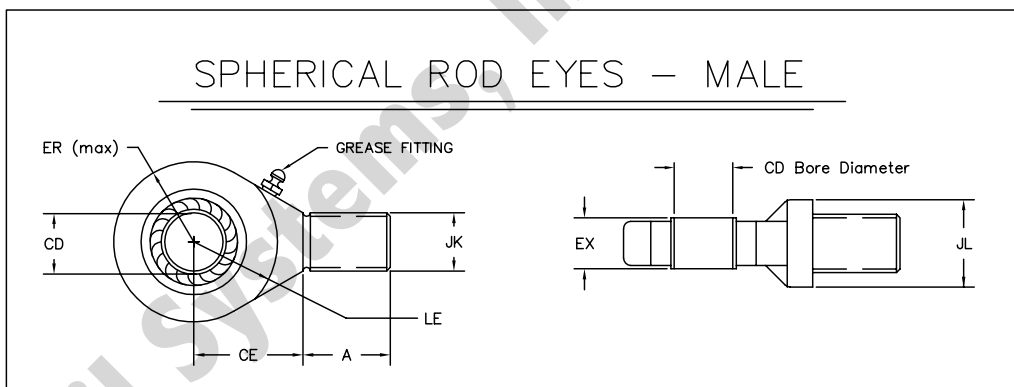

### MOUNTING DIMENSIONS

PART NO.	CD +.0000 -.0005	A	CE	EX	ER	LE	JK	JL	MAX HYD. CYLINDER BORE & PSIG	MAX LOAD CAPACITY IN POUNDS
LSRE-05M	.5000	11/16	7/8	.437	7/8	3/4	7/16-20	7/8	1 1/2 @ 1,200	2,600
LSRE-07M	.7500	1	1 1/4	.656	1 1/4	1 1/16	3/4-16	1 5/16	2 1/2 @ 1,400	9,400
LSRE-10M	1.0000	1 1/2	1 7/8	.875	1 3/8	1 7/16	1-14	1 1/2	3 1/4 @ 1,500	16,800
LSRE-13M	1.3750	2	2 1/8	1.187	1 13/16	1 7/8	1 1/4-12	2	4 @ 1,800	28,600
LSRE-17M	1.7500	2 1/8	2 1/2	1.531	2 3/16	2 1/8	1 1/2-12	2 1/4	5 @ 1,200	43,000
LSRE-20M	2.0000	2 7/8	2 3/4	1.750	2 5/8	2 1/2	1 7/8-12	2 3/4	6 @ 1,800	70,000

**NOTE: STAINLESS STEEL**

Part Numbers in the charts above and on page 57 are for standard Spherical Rod End and Cap End Accessories. All items are also available in **stainless steel**. For stainless steel accessories, add "S" to the end of the Part Number: e.g.; LSRE-05M for standard Male Spherical Rod Eye, LSRE-05MS for stainless steel Male Spherical Rod Eye.

# SPHERICAL CAP AND ROD END MOUNTING ACCESSORIES (Cont.)

## STANDARD AND STAINLESS STEEL

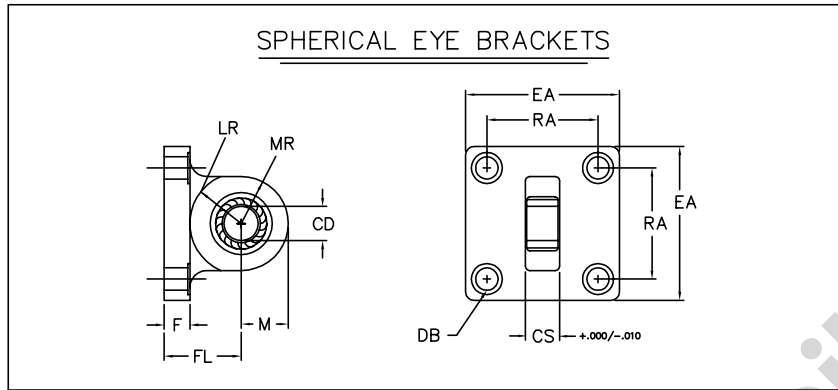

### MOUNTING DIMENSIONS

PART NO.	CD	CS	DB	EA	F	FL	LR	M	MR	RA
LSEB-05	.500	.50	13/32	2 1/2	3/8	1 1/8	3/4	11/16	11/16	1.62
LSEB-07	.750	.75	17/32	3 1/2	5/8	1 7/8	1 1/4	1 3/16	1 3/16	2.56
LSEB-10	1.000	1.00	21/32	4 1/2	3/4	2 1/4	1 1/2	1 3/8	1 3/8	3.25
LSEB-13	1.375	1.38	21/32	5	7/8	3	2 1/8	2	2	3.88
LSEB-17	1.750	1.50	29/32	6 1/2	7/8	3 1/8	2 1/4	2 1/8	2 1/8	4.94
LSEB-20	2.000	1.75	1 1/32	7 1/2	1	3 1/2	2 1/2	2 3/8	2 3/8	5.75

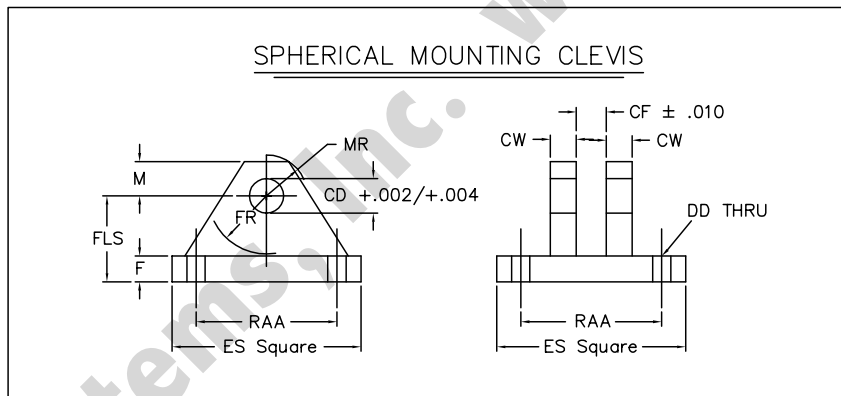

### MOUNTING DIMENSIONS

PART NO.	CD	CF	CW	DD	ES	F	FLS	FR	M	MR	RAA
LCBS-05	.500	.44	1/2	13/32	3	1/2	1 1/2	15/16	1/2	5/8	2.05
LCBS-07	.750	.66	5/8	17/32	3 3/4	5/8	2	1 3/8	7/8	1	2.76
LCBS-10	1.000	.88	3/4	17/32	5 1/2	3/4	2 1/2	1 11/16	1	1 3/16	4.10
LCBS-13	1.375	1.19	1	21/32	6 1/2	7/8	3 1/2	2 7/16	1 3/8	1 5/8	4.95
LCBS-17	1.750	1.53	1 1/4	29/32	8 1/2	1 1/4	4 1/2	2 7/8	1 3/4	2 1/16	6.58
LCBS-20	2.000	1.75	1 1/2	29/32	10 5/8	1 1/2	5	3 5/16	2	2 3/8	7.92

Note: Spherical mounting clevises are designed to mate with spherical cylinder mounting style 8S and with spherical rod eyes.

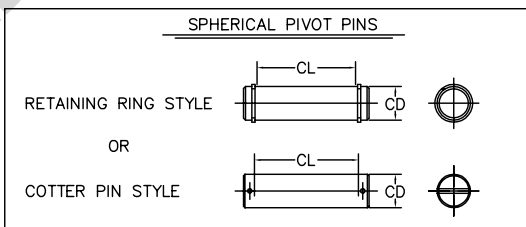

Note: Pivot pin is not supplied with any spherical rod end or cap end mounting accessory. It must be ordered as separate item if required.

### MOUNTING DIMENSIONS

PART NO.	CD	CL
LSP-05	.500	1 1/2
LSP-07	.750	2
LSP-10	1.000	2 7/16
LSP-13	1.375	3 1/4
LSP-17	1.750	4 3/32
LSP-20	2.000	4 13/16

# PISTON ROD SELECTION CHART FOR SERIES JHD AND LSSL AIR CYLINDERS

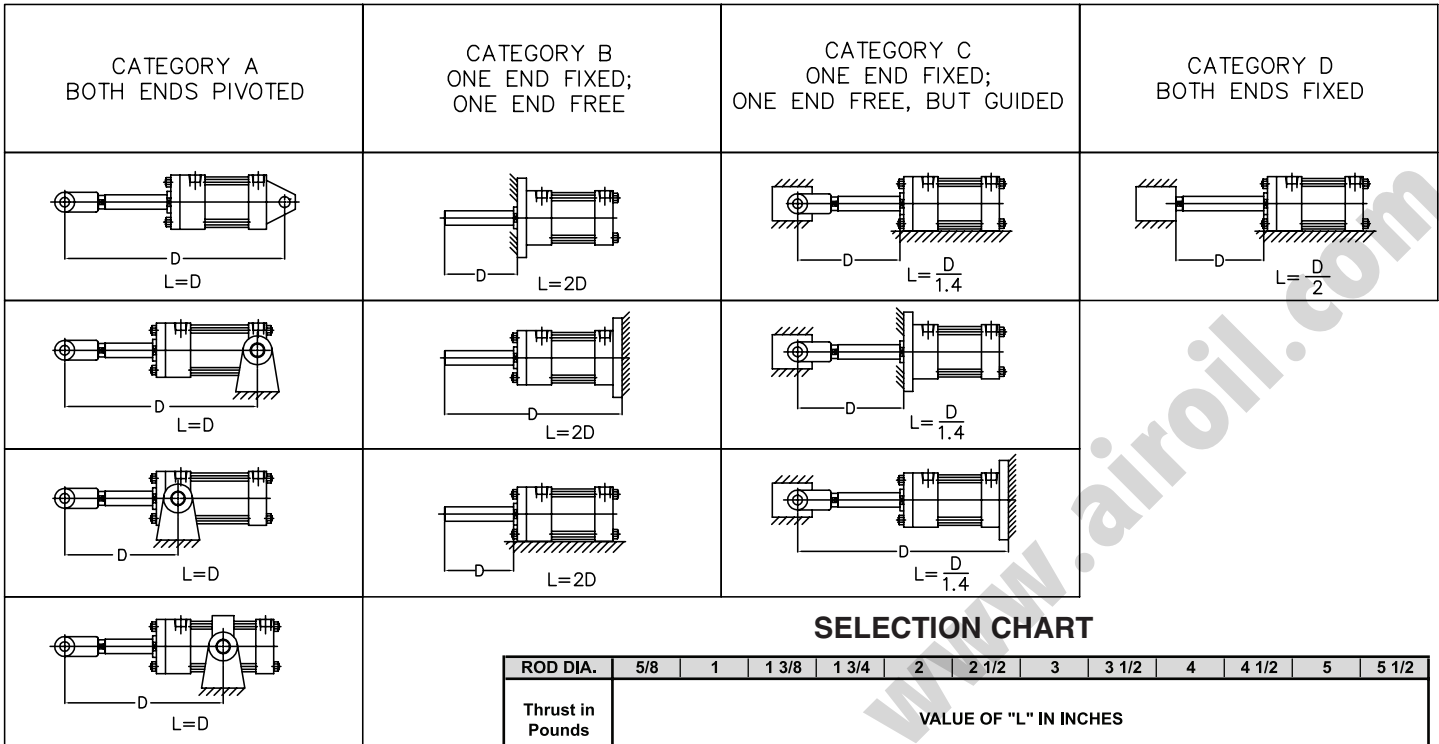

## DETERMINING PROPER PISTON ROD DIAMETER

To determine proper piston rod diameter for your specific application, follow the sequence outlined below:

**Step 1)** Determine the maximum extension thrust (push) in pounds that your selected bore cylinder will develop.

**Step 2)** Using the drawings above, locate your mounting category, noting the value of "L" in relation to extended cylinder dimension "D".

**Step 3)** Prior to determining the final "D" dimension in inches, check to see if cylinder stop is necessary for proper cylinder operation. As a general rule, whenever stroke length exceeds 40", use 1" of stop tube length for each additional 10" of stroke.

*Example: If stroke is 54", the stop tube length should be 2"*

Cylinders in categories C and D normally do not require stop tube due to the guided loads.

## SELECTION CHART

ROD DIA.	5/8	1	1 3/8	1 3/4	2	2 1/2	3	3 1/2	4	4 1/2	5	5 1/2
Thrust in Pounds	VALUE OF "L" IN INCHES											
50	67											
100	59	110										
150	53	103										
250	43	94	146									
400	37	83	134	186								
700	30	68	118	168	202	275						
1,000	27	60	105	155	190	257	330					
1,400	24	53	92	142	174	244	308	385				
1,800	23	48	82	127	160	230	296	366	440			
2,400	19	45	75	114	145	213	281	347	415	488		
3,200	16	41	67	103	130	194	261	329	400	461		
4,000	13	38	63	94	119	175	240	310	378	446		
5,000	9	34	60	87	110	163	225	289	360	426	494	
6,000		30	56	82	102	152	208	274	342	410	476	
8,000		26	50	76	93	137	188	245	310	375	447	
10,000		21	45	70	89	125	172	222	279	349	412	482
15,000			36	61	78	114	154	197	248	326	388	454
20,000			28	52	68	103	136	172	218	292	350	420
25,000			20	45	61	95	128	164	203	270	326	385
30,000				39	55	87	120	156	189	230	285	330
40,000				22	43	74	108	142	177	210	248	294
50,000					30	66	96	130	165	200	234	269
60,000						57	88	119	154	190	225	256
80,000						36	71	104	137	170	204	240
100,000							57	90	120	154	199	222

**Step 4)** Determine final value of "D" in inches, including stop tube addition if applicable. Convert "D" dimension to chart value "L" in inches, using formula shown on applicable drawing.

**Step 5)** From the Selection Chart, locate the line showing the maximum "Thrust in Pounds" and read to the right until the approximate value of "L" is located. Read vertically upward to find the necessary rod diameter in inches.

*Example: If the maximum thrust is 5,000 lbs., and value of "L" has been determined as 110", the minimum rod diameter recommended would be 2"*

**Step 6)** Note that in some cases the recommended minimum rod diameter may exceed that which is possible for the cylinder bore size selected. In such cases it may be necessary to select a larger bore size cylinder operating at a lower pressure which will still provide the required operation thrust. The larger cylinder may accommodate a larger rod size which will meet the minimum requirement.



# PUSH AND PULL FORCES FOR PNEUMATIC CYLINDERS

## THEORETICAL PUSH FORCE, IN POUNDS

BORE	PISTON AREA SQ. IN.	PUSH FORCE IN LBS OBTAINED AT FOLLOWING PRESSURES						CU. FT. FREE AIR @ 80 PSI REQ'D TO MOVE MAX. LOAD 1 INCH	CU. FT. DISPLACED PER INCH OF STROKE
		60 PSI	80 PSI	100 PSI	150 PSI	200 PSI	250 PSI		
1 1/2	1.77	106	142	177	266	354	443	.007	.0010
2	3.14	188	251	314	471	628	785	.012	.0018
2 1/2	4.91	295	393	491	736	982	1228	.018	.0028
3 1/4	8.30	498	664	830	1245	1660	2075	.031	.0048
4	12.57	754	1006	1257	1886	2514	3143	.047	.0073
5	19.64	1178	1571	1964	2946	3925	4910	.073	.0114
6	28.27	1696	2262	2827	4241	5654	7068	.105	.0164
8	50.27	3016	4022	5027	7541	10053	12568	.187	.0291
10	78.54	4712	6283	7854	11781	15708	19635	.293	.0455
12	113.10	6786	9048	11310	16965	22620	28275	.422	.0655
14	153.94	9236	12315	15394	23091	30788	38485	.574	.0891
16	201.06	12064	16085	20106	30159	40212	50265	.750	.1164
18	254.47	15268	20358	25447	38171	50894	63618	.949	.1473
20	314.16	18850	25133	31416	47124	62832	78540	1.171	.1818

This table lists full piston areas and push force values on the extend stroke at various input pressures. The formula used is:  $F = PA$  (Force = Pressure x Area). Also listed are displacement values in cubic feet by bore size and the corresponding value of cubic feet of free air required to move the piston one inch.

## DEDUCTIONS FOR PULL FORCE, IN POUNDS, PER ROD DIAMETER

PISTON ROD DIA.	PISTON ROD AREA SQ. IN.	FOR PULL STROKE FORCE, DEDUCT FROM THE PUSH FORCE THE FORCE CORRESPONDING TO ROD SIZE AND PRESSURE						CU. FT. FREE AIR @ 80 PSI REQ'D TO MOVE MAX. LOAD 1 INCH	CU. FT. DISPLACED PER INCH OF STROKE
		60 PSI	80 PSI	100 PSI	150 PSI	200 PSI	250 PSI		
5/8	.306	18	24	31	46	61	77	.001	.0002
1	.785	47	63	79	118	157	196	.003	.0005
1 3/8	1.485	89	119	149	223	297	371	.006	.0009
1 3/4	2.405	144	192	241	361	481	601	.009	.0014
2	3.142	188	251	314	471	628	786	.012	.0018
2 1/2	4.909	295	393	491	736	982	1227	.018	.0028
3	7.069	424	566	707	1060	1414	1767	.026	.0041
3 1/2	9.621	577	770	962	1443	1924	2405	.036	.0056
4	12.566	754	1005	1257	1885	2513	3142	.047	.0073
4 1/2	15.904	954	1272	1590	2386	3181	3976	.059	.0092
5	19.635	1178	1571	1964	2945	3927	4909	.073	.0114
5 1/2	23.758	1425	1901	2376	3564	4752	5940	.087	.0138

This table lists the rod areas and the corresponding force and displacement values calculated in the same manner as those for pistons in the top table. To determine the values of the pull force and the cubic feet of free air on the retract stroke, deduct those values in the table for the rod size of your cylinder.

*Example: Assume a 4" bore cylinder with a 2" diameter rod operating at 80 PSI. Using the charts, the following theoretical values are obtained:*  
 Push (or Extend) Force = 1,006 lbs.  
 Pull (or Retract) Force = 755 lbs (1,006 lbs from the top table, less 251 lbs from the bottom table)

## WARRANTY

Seller warrants its products free from defects in material and workmanship for a period of one year from date of shipment. This warranty excludes normal wear attributable to the particular application in which the product is used.

Further, this warranty is limited exclusively to the replacement or repair of defective products, which, in the opinion of Lehigh Fluid Power, Inc., have not been modified, misused, misapplied, repaired or altered by the user.

Lehigh Fluid Power, Inc. accepts no responsibility or liability for damages to the purchaser arising out of a delay in or failure of delivery or resulting from any breach of any other term or obligation of Lehigh under this contract.

In order to make a claim, buyer must notify Lehigh within the warranty period. Promptly after receiving such notification, Lehigh will either examine the product at the user's site or issue shipping instructions for return to it, transportation costs prepaid by buyer. All items returned must be accompanied by a copy of this acknowledgment.

The above warranty comprises Lehigh's sole and entire obligation and liability to buyer and all of those claiming under buyer as to the products sold hereunder. All other warranties, express or implied, including but not limited to, warranties of merchantability and fitness, are expressly excluded.

These terms and conditions of sale constitute the complete and exclusive statement of agreement superseding all oral or written communications and any prior agreements between the parties relating to its subject matter.

THE COMPANY'S ACCEPTANCE OF THIS ORDER IS MADE EXPRESSLY CONDITIONAL UPON THE FOREGOING TERMS AND CONDITIONS.



Manufacturer of NFPA Industrial Pneumatic and Hydraulic Tie Rod Cylinders

Lehigh Fluid Power, Inc.  
1413 Route 179  
Lambertville, NJ 08530

800.257.9515  
609.397.3487

Fax: 609.397.0932

[www.lehighfluidpower.com](http://www.lehighfluidpower.com)  
[sales@lehighfluidpower.com](mailto:sales@lehighfluidpower.com)