

MXB BELT DRIVEN ACTUATORS

ENDURANCE TECHNOLOGY™

U UNGUIDED

P PROFILED RAIL



MAXIMUM DURABILITY

CONTENTS

MXB Belt Driven Actuator	3
Belt Drive Advantages	3
Belt Construction	3
Applications	3
MXB-U Features.....	4
MXB-P Features.....	6
Specifications	8
Acceleration	9
Mounting Plate Requirements.....	9
Moment & Load Capacity.....	10
Load Deflection	11
MXB-U Actuator Dimensions.....	12
MXB-U Option Dimensions.....	12
MXB-P Actuator Dimensions.....	13
MXB-P Option Dimensions	14
Direct Drive Motor Mounting	15
Reduction Drive Motor Mounting..	18
Switches	20
Application Data Worksheet	22
Selection Guidelines	23
Motors, Drives & Controllers.....	24
Service Parts Ordering.....	26
Ordering	27
Other Tolomatic Products.....	28

THE MXB BELT DRIVEN ELECTRIC ACTUATOR - DESIGNED TO OUTLAST EVERY BELT DRIVEN ACTUATOR ON THE MARKET



The MXB belt driven electric actuator is exactly what you would expect from the industry's number one rodless supplier. Designed with our exclusive **ENDURANCE TECHNOLOGY™** features, the MXB delivers superior performance to meet the most demanding applications. Nobody knows rodless like Tolomatic, and the MXB proves it.

- MXB-**U** & MXB-**P**: Low profile to fit your application
- MXB-**P**: High precision bearings feature smooth, low breakaway motion
- MXB-**P**: Durable profiled rail design uses THK® Caged Ball® technology to reduce friction and extend actuator life.
- MXB-**P**: High load and bending moment capacities

Choose from our broad line of MX products:

ELECTRIC				PNEUMATIC		
MXB		MXE		MXP		
Belt Driven		Screw Driven		Rodless Cylinder		
P Profiled Rail	U Unguided	P Profiled Rail	S Solid Bearing	P Profiled Rail	S Solid Bearing	N Internal Bearing
MXB16P	MXB16U	MXE16P	MXE16S	MXP16P	MXP16S	MXP16N
MXB25P	MXB25U	MXE25P	MXE25S	MXP25P	MXP25S	MXP25N
MXB32P	MXB32U	MXE32P	MXE32S	MXP32P	MXP32S	MXP32N
MXB40P	MXB40U	MXE40P	MXE40S	MXP40P	MXP40S	MXP40N
MXB50P	MXB50U	MXE50P	MXE50S	MXP50P	MXP50S	MXP50N
MXB63P	MXB63U	MXE63P	MXE63S	MXP63P	MXP63S	MXP63N

World class performance, five days built-to-order and legendary customer service ... what you expect from the rodless leader ... Tolomatic!

MXB Belt Driven Actuator

ADVANTAGES OF BELT SOLUTIONS

The use of synchronous belts, often referred to as timing belts, have become a standard in the automated motion industry as an alternate to screw drive mechanisms for producing linear motion. MXB-**U** and MXB-**P** belt driven actuators are an excellent solution for applications that require:

- High linear velocities
- High acceleration rates
- Long stroke lengths
- Excellent repeatability
- High duty cycles

Tolomatic belt driven actuators can achieve linear acceleration up to 1200 in/sec², MXB-U velocity of up to 200 in/sec (5 m/sec) and MXB-P velocity of up to 150 in/sec (3.8 m/sec).

BELT DRIVEN APPLICATIONS

Tolomatic MXB-**U** and MXB-**P** belt driven actuators are:

- Easy to size and order
- Quick to install and maintain
- Simple to integrate and control

Both MXB-U and MXB-P are available in multiple frame sizes. The MXB-P belt driven actuator integrates the advantages of a linear belt solution with a load support and guidance system. This combination allows you to install a pre-assembled and compact solution, often without the need of external guide rails or load support systems. MXB-P offers options such as dual carriers for twice the load and moment capacity.

U APPLICATION: Workcenter Positioning

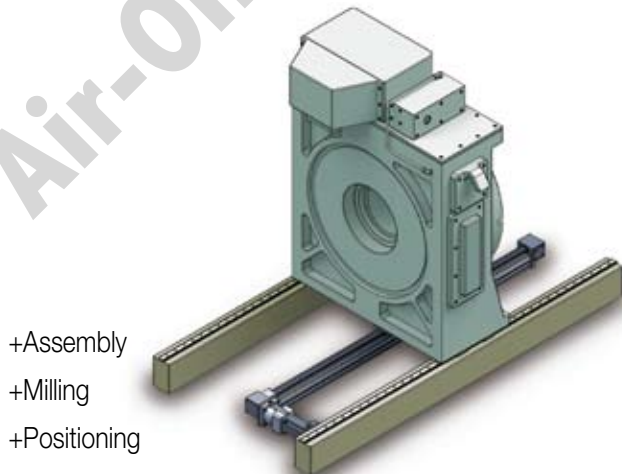

- +Assembly
- +Milling
- +Positioning

BELT CONSTRUCTION

Tolomatic's standard belt is a polyurethane material reinforced with steel tension members to produce high carrier thrusts without belt stretch.

Tolomatic uses an HTD synchronous belt that features a curvilinear tooth profile. The HTD tooth profile distributes tooth load more evenly and provides greater tooth shear strength, allowing for higher thrust loading.

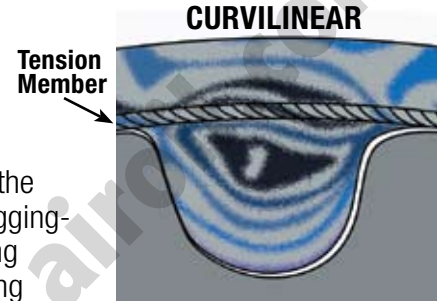

The deep teeth of the HTD profile are cogging-resistant, preventing potentially damaging positioning errors.

Tolomatic's belt tooth profile distributes thrust force evenly

P APPLICATION: High Speed Flying Cut Off

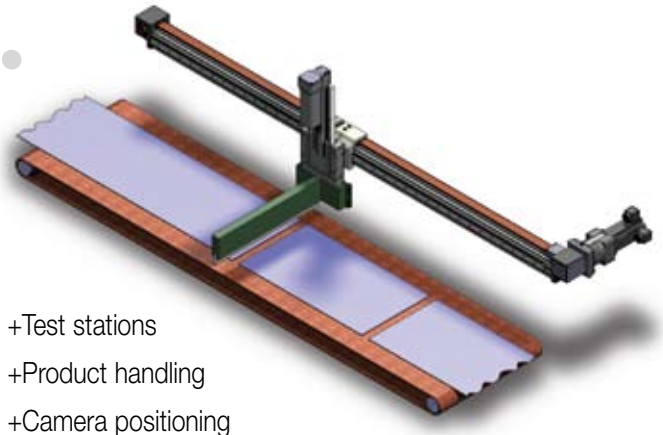

- +Test stations
- +Product handling
- +Camera positioning

P APPLICATION: X-Y Multi-Axis

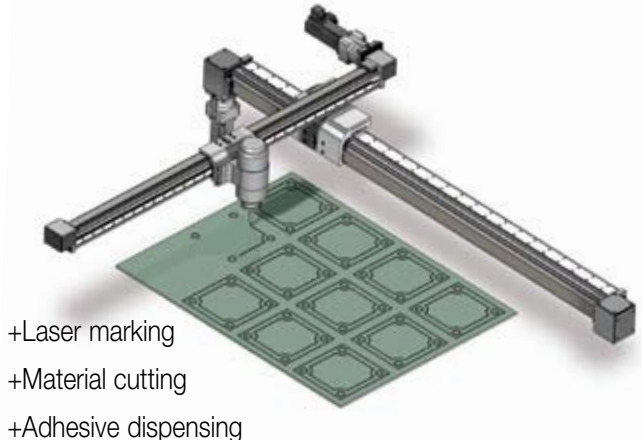

- +Laser marking
- +Material cutting
- +Adhesive dispensing

MXB-**U** BELT DRIVE (UNGUIDED)

ENDURANCE TECHNOLOGYSM

Endurance TechnologySM features are designed for maximum durability to provide extended service life.

• MOTOR ORIENTATION •

YOU CAN CHOOSE:

- Direct drive option directly couples motor to the drive shaft; one-piece housing construction for optimum alignment and support of the motor
- Reduction option in 3:1 reduction (2:1 on MXB16)

• INCH OR METRIC MOUNTING •

- Your choice of blank, inch (US standard) or metric mounting to the plate

• YOUR MOTOR HERE •

YOU CAN CHOOSE:

- Motor or gearbox supplied and installed by Tolomatic
- Specify the device to be installed and actuator ships with proper mounting hardware - MXB is a "Your Motor Here" actuator for easy direct drive motor installation. Check our website (www.tolomatic.com/y mh) for complete information
- Specify and ship your device to Tolomatic for factory installation

• OVERSIZED PULLEY BEARINGS •

- Drive shaft assembly incorporates oversized shielded/sealed ball bearings for long life and high speeds

**5 DAYS
BUILT-TO-ORDER**

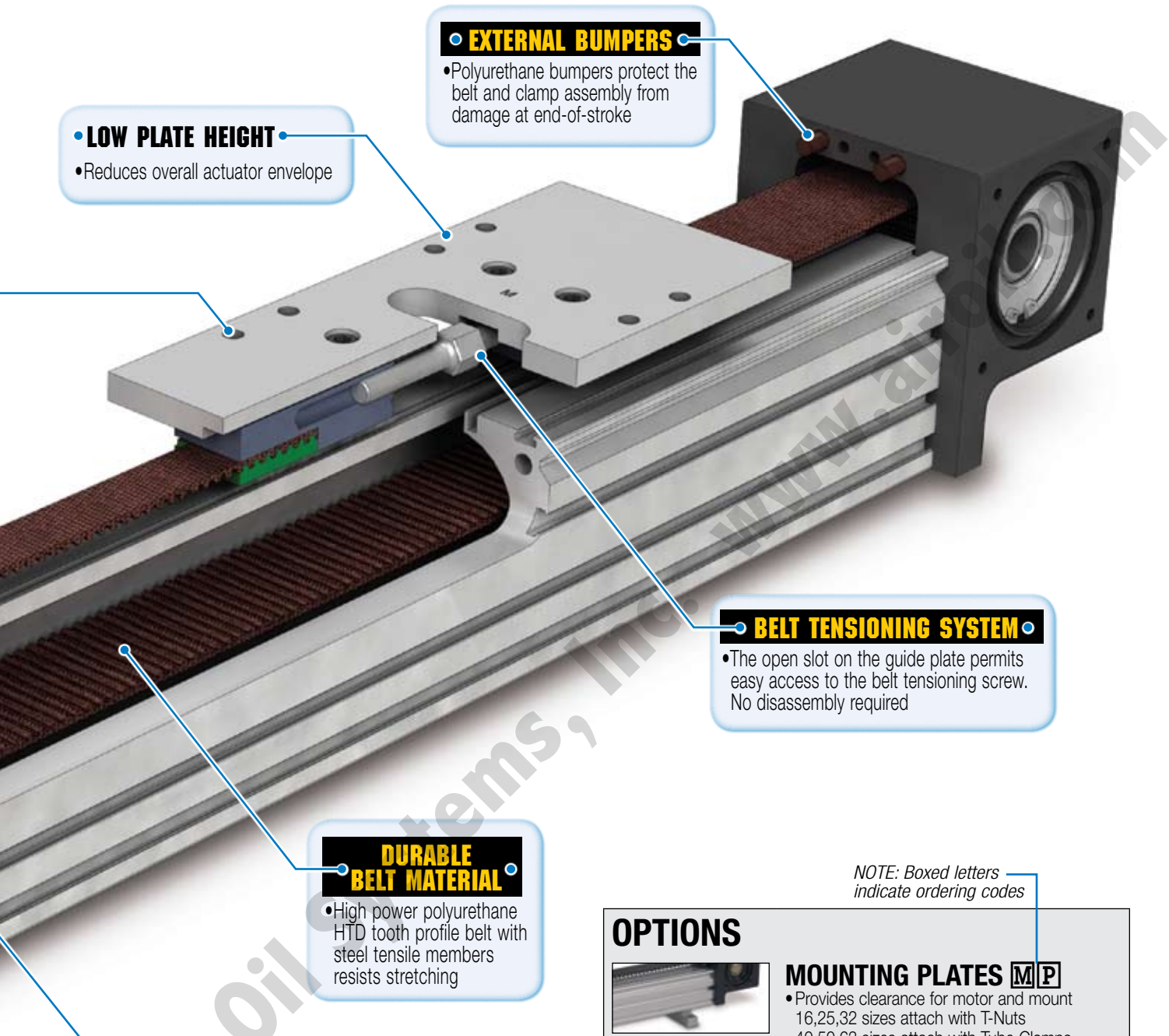

• LOW PLATE HEIGHT

- Reduces overall actuator envelope

• EXTERNAL BUMPERS

- Polyurethane bumpers protect the belt and clamp assembly from damage at end-of-stroke

• BELT TENSIONING SYSTEM

- The open slot on the guide plate permits easy access to the belt tensioning screw. No disassembly required

DURABLE BELT MATERIAL

- High power polyurethane HTD tooth profile belt with steel tensile members resists stretching

• LIGHTWEIGHT ALUMINUM DESIGN

- Clear anodized extrusion design is optimized for rigidity and strength

NOTE: Boxed letters indicate ordering codes

OPTIONS



MOUNTING PLATES MP

- Provides clearance for motor and mount
- 16,25,32 sizes attach with T-Nuts
- 40,50,63 sizes attach with Tube Clamps



HEAD COVER PLATE HCP

- Provides protection for pulley and bearing



TUBE CLAMPS TC

- Used for intermediate support
- Flush with bottom of actuator to retain low profile
- Drop-in, adjustable mounting locations (Not available on the MXB16U)

MXB-**P** BELT DRIVE (PROFILED RAIL)

ENDURANCE TECHNOLOGYSM

Endurance TechnologySM features are designed for maximum durability to provide extended service life.

CAGED BALL[®] BEARINGS

- THK[®] Caged Ball[®] bearings are used to reduce friction and extend actuator life
- Caged Ball[®] technology creates a grease pocket between ball elements, reducing friction, noise and maintenance
- Large permissible moment loads
- High speed operation, low heat generation
- High precision, smooth, low friction motion

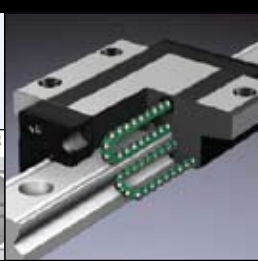
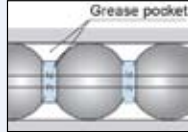

DURABLE BELT MATERIAL

- High power polyurethane HTD tooth profile belt with steel tensile members resists stretching

OVERSIZED PULLEY BEARINGS

- Drive shaft assembly incorporates oversized shielded/sealed ball bearings for long life and high speeds

INCH OR METRIC MOUNTING

- Your choice of inch (US standard) or metric mounting to the carrier

MOTOR ORIENTATION

YOU CAN CHOOSE:

- Direct drive option directly couples motor to the drive shaft; one-piece housing construction for optimum alignment and support of the motor
- Reduction option in 3:1 reduction (2:1 on MXB16)

YOUR MOTOR HERE

YOU CAN CHOOSE:

- Motor or gearbox supplied and installed by Tolomatic
- Specify the device to be installed and actuator ships with proper mounting hardware - MXB is a "Your Motor Here" actuator for easy direct drive motor installation. Check our website (www.tolomatic.com/ymh) for complete information
- Specify and ship your device to Tolomatic for factory installation

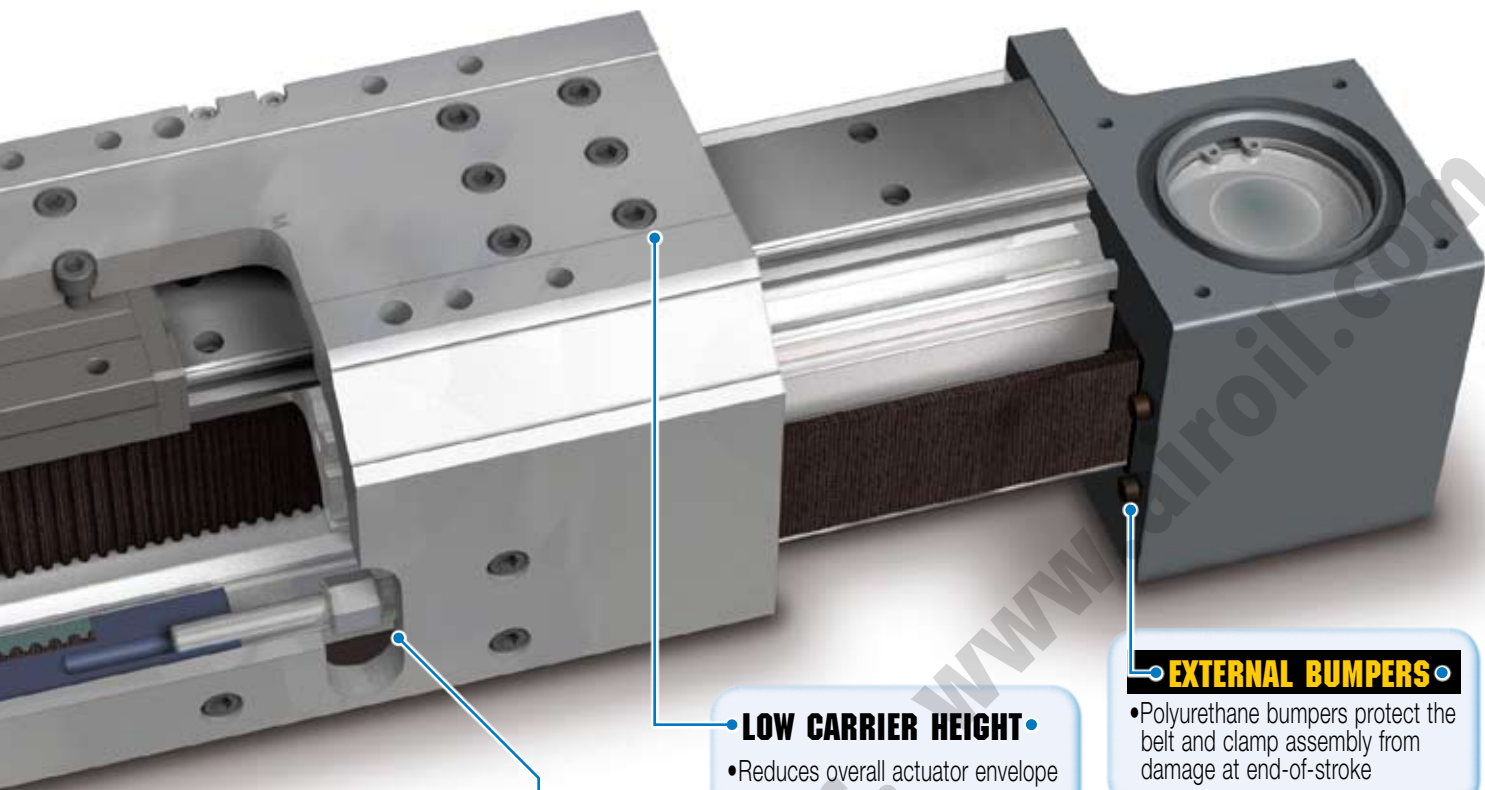

BELT TENSIONING SYSTEM

- The open slot on the carrier side permits easy access to the belt tensioning screw. No disassembly required and no need to remove the load from the carrier

LIGHTWEIGHT ALUMINUM DESIGN

- Clear anodized extrusion design is optimized for rigidity and strength

LOW CARRIER HEIGHT

- Reduces overall actuator envelope
- Large mounting pattern for excellent load stability

EXTERNAL BUMPERS

- Polyurethane bumpers protect the belt and clamp assembly from damage at end-of-stroke

NOTE: Boxed letters indicate ordering codes

OPTIONS

	<p>AUXILIARY CARRIER DC</p> <ul style="list-style-type: none"> 2X higher Fz & Fy (load) capacity High bending moment capacity
	<p>MOUNTING PLATES MP</p> <ul style="list-style-type: none"> Provides clearance for motor and mount 16,25,32 sizes attach with T-Nuts 40,50,63 sizes attach with Tube Clamps
	<p>TUBE CLAMPS TC</p> <ul style="list-style-type: none"> Used for intermediate support Flush with bottom of actuator to retain low profile Drop-in adjustable mounting locations <p>(Not available on the 16, 25 or 32 MXB-P sizes)</p>
	<p>HEAD COVER PLATE HCP</p> <ul style="list-style-type: none"> Provides protection for pulley and bearing
	<p>SWITCHES</p> <ul style="list-style-type: none"> Wide variety of sensing choices: Reed, Solid State PNP or NPN, available normally open or normally closed Flush mount, drop-in installation Bright LEDs, power & signal indication CE rated, RoHS compliant

5 DAYS
BUILT-TO-ORDER

MXB Belt Driven Actuator

ACTUATOR SPECIFICATIONS AND BREAKAWAY TORQUE

U & P MXB SIZE	BELT WIDTH		BELT DEAD LENGTH		PULLEY PITCH DIAMETER		STROKE PER REVOLUTION		*MAXIMUM STROKE		BREAKAWAY TORQUE			
											SINGLE CARRIER		AUXILIARY CARRIER OPT. (MXB-P ONLY)	
	in	mm	in	mm	in	mm	in	mm	in	mm	lb-in	N-m	lb-in	N-m
16	0.39	10	14.29	363.0	0.753	19.1	2.366	60.1	200	5080	4.0	0.452	6.0	0.678
25	0.71	18	18.72	475.5	1.003	25.5	3.151	80.0	200	5080	5.0	0.565	7.0	0.791
32	0.98	25	21.89	556.0	1.253	31.8	3.936	100.0	200	5080	8.0	0.904	10.0	1.130
40	1.18	30	24.95	633.7	1.504	38.2	4.725	120.0	200	5080	10.0	1.130	12.0	1.356
50	1.57	40	27.25	692.2	1.754	44.6	5.510	140.0	160	4064	15.0	1.695	18.0	2.034
63	1.97	50	36.11	917.2	2.130	54.1	6.692	170.0	100	2540	20.0	2.260	25.0	2.825

*Longer lengths may be possible with use of tube couplers - Contact Tolomatic

U MXB-U SIZE	WEIGHT								INERTIA							
	PLATE ASSEMBLY		BELT TENSIONER ASSEMBLY		BASE ACTUATOR		PER UNIT OF STROKE		DRIVE/IDLE PULLEY ASSEMBLIES		PLATE ASSEMBLY (INCLUDING BELT TENSIONER ASSEMBLY)		PER UNIT OF STROKE			
	lb	kg	lb	kg	lb	kg	lb/in	kg/cm	lb-in ²	kg-cm ²	lb-in ²	kg-cm ²	lb-in ²	kg-cm ²		
16	0.11	0.05	0.10	0.05	1.59	0.72	0.084	0.0150	0.0085	0.0250	0.0335	0.0980	0.0005	0.0006		
25	0.27	0.12	0.15	0.07	2.59	1.17	0.138	0.0246	0.0259	0.0759	0.1201	0.3515	0.0017	0.0020		
32	0.48	0.22	0.30	0.13	4.17	1.89	0.237	0.0423	0.1416	0.4143	0.3451	1.0099	0.0037	0.0043		
40	0.90	0.41	0.46	0.21	7.83	3.55	0.352	0.0629	0.3719	1.0884	0.8487	2.4836	0.0065	0.0075		
50	1.03	0.47	0.72	0.33	9.93	4.50	0.472	0.0843	0.7243	2.1196	1.5103	4.4198	0.0117	0.0135		
63	2.54	1.15	0.83	0.38	16.44	7.46	0.833	0.1488	1.9512	5.7101	4.2168	12.3401	0.0216	0.0249		

P MXB-P SIZE	WEIGHT								INERTIA							
	CARRIER ASSEMBLY		BELT TENSIONER ASSEMBLY		BASE ACTUATOR		PER UNIT OF STROKE		DRIVE/IDLE PULLEY ASSEMBLIES		CARRIER ASSEMBLY (INCLUDING BELT TENSIONER ASSEMBLY)				PER UNIT OF STROKE	
	lb	kg	lb	kg	lb	kg	lb/in	kg/cm	lb-in ²	kg-cm ²	SINGLE CARRIER		AUXILIARY CARRIER OPT.		lb-in ²	kg-cm ²
16	0.39	0.18	0.10	0.05	2.38	1.08	0.102	0.0183	0.0085	0.0250	0.4856	1.4211	0.8716	2.5506	0.0005	0.0006
25	0.84	0.38	0.15	0.07	4.36	1.98	0.195	0.0348	0.0259	0.0759	0.9914	2.9013	1.8353	5.3708	0.0017	0.0020
32	1.64	0.74	0.30	0.13	7.83	3.55	0.318	0.0569	0.1416	0.4143	1.9356	5.6642	3.5757	10.4641	0.0037	0.0043
40	2.51	1.14	0.46	0.21	14.07	6.38	0.537	0.0959	0.3719	1.0884	2.9693	8.6893	5.4832	16.0460	0.0065	0.0075
50	5.03	2.28	0.72	0.33	20.84	9.45	0.749	0.1337	0.7243	2.1196	5.7498	16.8263	10.7770	31.5378	0.0117	0.0135
63	9.36	4.25	0.83	0.38	37.24	16.89	1.110	0.1981	1.9512	5.7101	10.1930	29.8288	19.5537	57.2221	0.0216	0.0249

MAXIMUM VELOCITY U 200 in/sec 5080 mm/sec

MAXIMUM VELOCITY P 150 in/sec 3810 mm/sec

MAXIMUM ACCELERATION 1200 in/sec² 30.48 m/sec²

REPEATABILITY ± 0.002 in ± 0.051 mm

TEMPERATURE RANGE 10 to 130 °F -12 to 54 °C

⚠ Heat generated by the motor and drive should be taken into consideration as well as linear velocity and work cycle time. For applications that require operation outside of the recommended temperature range, contact the factory.

STRAIGHTNESS, FLATNESS 0.00067 L in 0.01702 L mm

Actuator mounted on a flat surface and fully restrained (see Mounting Plate Requirements, page 9) L = Maximum distance between supports

⚠ The listed values relating to straightness/flatness are intended for reference purposes only, and not as an engineering standard of absolute tolerance for a given actuator. Appropriate installation is the single most important factor in reducing variation, so good engineering practices such as measurement, mapping, etc. must be employed in applications with stringent straightness/flatness requirements.

MXB Belt Driven Actuator

MAXIMUM ACCELERATION AS A FUNCTION OF LOAD WEIGHT (U & P)

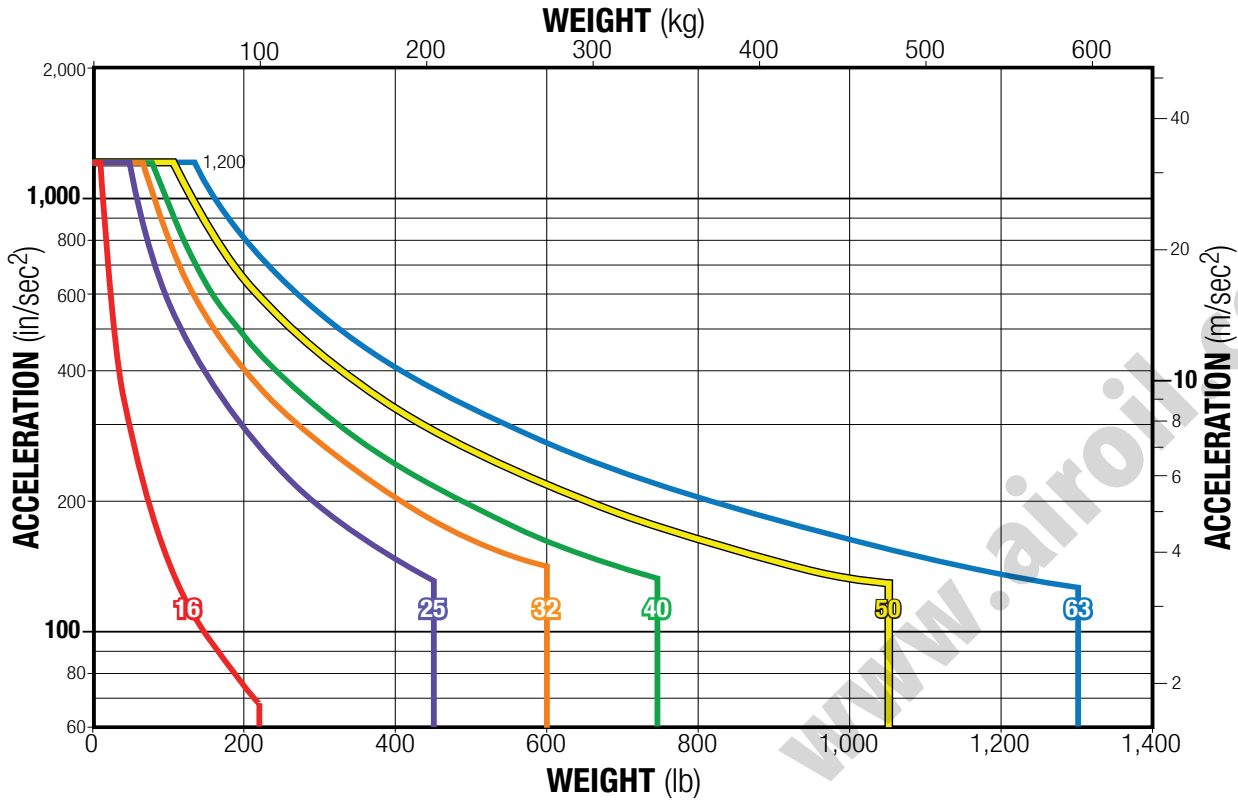

MOUNTING PLATE REQUIREMENTS (P ONLY)

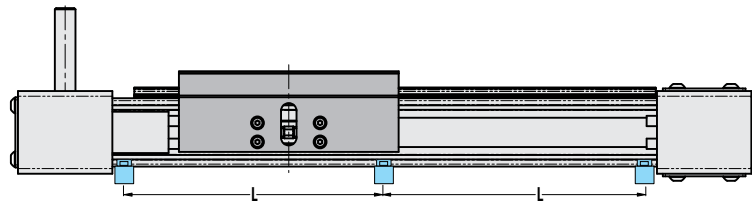
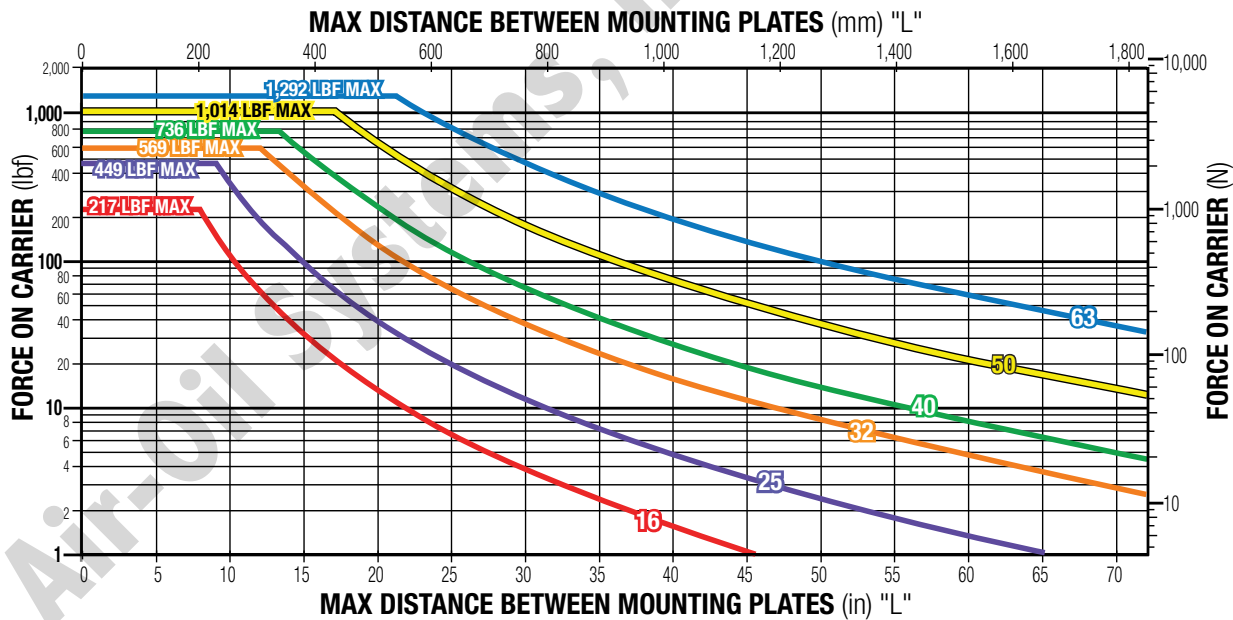

MXB-P Belt Driven Actuator

MOMENT AND LOAD CAPACITY

⚠ Mating surface of mounted component must maintain a flatness of at least .0015" [0.040 mm]

STANDARD CARRIER

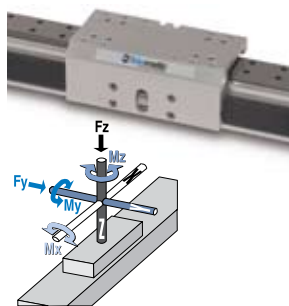

SIZE	MAXIMUM BENDING MOMENTS						MAXIMUM LOAD				MAXIMUM THRUST	
	Mx		My		Mz		Fy		Fz		lbf	N
	in-lbs	N-m	in-lbs	N-m	in-lbs	N-m	lbf	N	lbf	N	lbf	N
16	39	4.5	339	38.3	339	38.3	217	966	217	966	38	169
25	126	14.3	502	56.7	377	42.6	449	1,996	449	1,996	151	672
32	226	25.6	1,344	152	1,344	152	569	2,531	569	2,531	209	930
40	604	68.2	1,913	216	1,913	216	736	3,274	736	3,274	250	1,112
50	811	91.7	3,483	394	3,483	394	1,014	4,510	1,014	4,510	325	1,446
63	1,019	115	5,339	603	5,339	603	1,292	5,745	1,292	5,745	418	1,859

AUXILIARY CARRIER

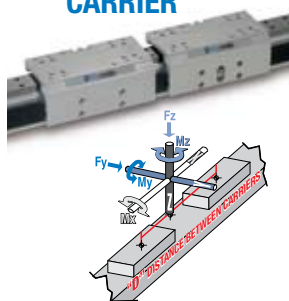

SIZE	"D" MINIMUM		MAXIMUM BENDING MOMENTS*						MAXIMUM LOAD			
	in	mm	Mxa		Mya		Mza		Fya		Fza	
			in-lbs	N-m	in-lbs	N-m	in-lbs	N-m	lbf	N	lbf	N
16	5.0	127	79	8.9	620	70.0	620	70.0	434	1,932	434	1,932
25	6.0	152	252	28.5	1,610	182	1,610	182	898	3,993	898	3,993
32	7.0	178	453	51.1	2,202	249	2,202	249	1,138	5,063	1,138	5,063
40	8.5	216	1,208	136	3,601	407	3,601	407	1,472	6,549	1,472	6,549
50	8.6	218	1,623	183	4,966	561	4,966	561	2,028	9,020	2,028	9,020
63	13.0	330	2,038	230	9,508	1,074	9,508	1,074	2,583	11,490	2,583	11,490

*At minimum "D" distance - see page 11 for bending moments at greater distances



Use sizing software or call Tolomatic (1-800-328-2174) with application information. We will provide any assistance needed to determine the proper MXB belt-driven actuator.

⚠ **The above ratings are the maximum values for shock-free, vibration-free operation in a typical industrial environment, which must not be exceeded even in dynamic operation. Contact Tolomatic for assistance in selecting the most appropriate actuator for your application.**

SPEED FACTOR

FOR APPLICATIONS WITH HIGH SPEED OR SIGNIFICANT SHOCK AND VIBRATION: Calculated values of loads and bending moments must be increased by speed factor from the graph at right to obtain full rated life of profiled rail bearing system.

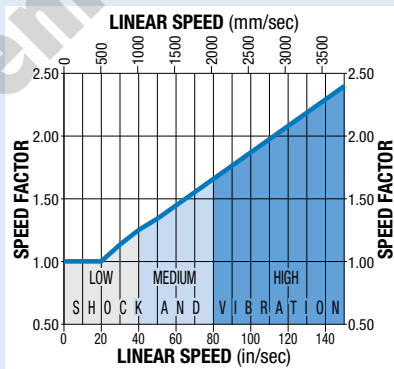

PROFILED RAIL LUBRICATION

Proper lubrication of profiled rail bearing system is essential for normal operation and achievement of full rated life of MXB-P actuators. Lubrication should be performed at intervals of 4,000,000 inches of travel or once every year, whichever occurs first. **However, operating conditions such as high speed or significant shock and vibration may require more frequent lubrication.** Please consult Tolomatic for recommendations.

Recommended grease types:

1. Refined mineral oil-based multi-purpose grease with lithium thickening agent.
2. High-grade synthetic oil-based grease with urea thickening agent.

The moment and load capacity of the actuator's bearing system is based on an L10 life of 200,000,000 linear inches of travel. Life of the actuator will vary for each application depending on the combined loads, motion parameters and operating conditions. The load factor (L_f) for each application must not exceed a value of 1 (as calculated below). Exceeding a load factor of 1 will diminish the actuator's rated life.

$$L_f = \frac{M_x}{M_{x_{max}}} + \frac{M_y}{M_{y_{max}}} + \frac{M_z}{M_{z_{max}}} + \frac{F_y}{F_{y_{max}}} + \frac{F_z}{F_{z_{max}}} \leq 1$$

With combined loads, L_f must not exceed the value 1.

MXB-P Belt Driven Actuator

LOAD DEFLECTION

DEFLECTION TESTING WAS DONE UNDER THESE CRITERIA:

- 1.) Actuator was properly mounted with distance between mounting plates within recommendations
- 2.) Deflection was measured at 12" from center of carrier as shown (see Mounting Plate Requirements page 9)

DEFLECTION ABOUT X AXIS

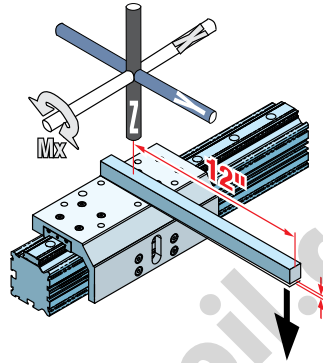
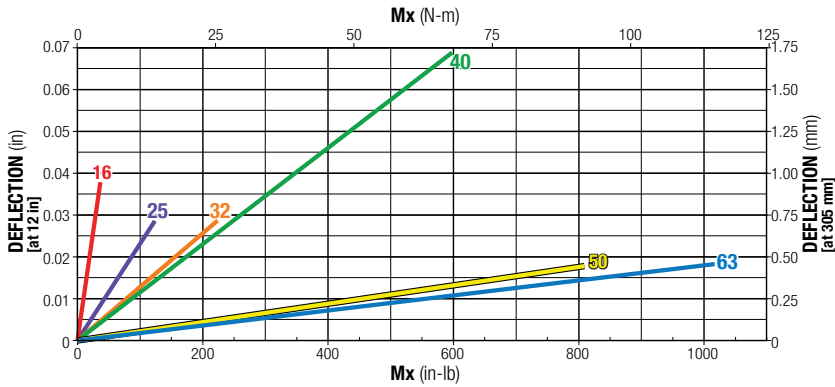

DEFLECTION ABOUT Y AXIS

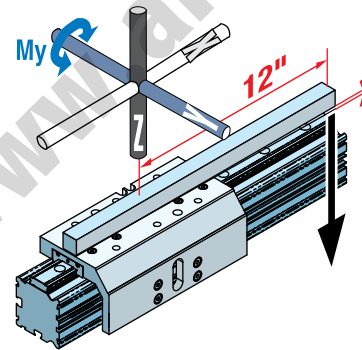
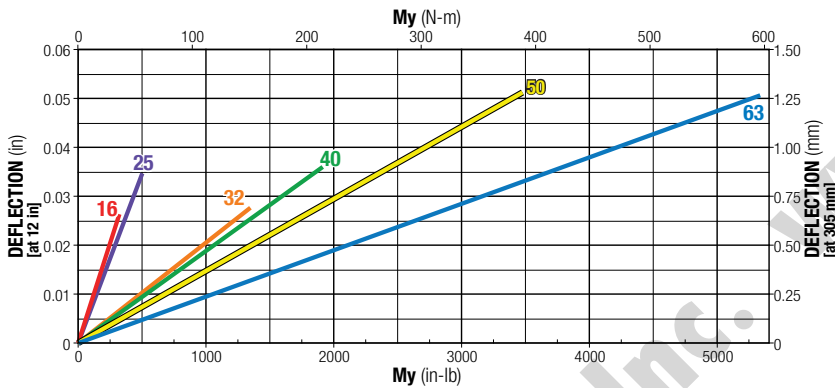

DEFLECTION ABOUT Z AXIS

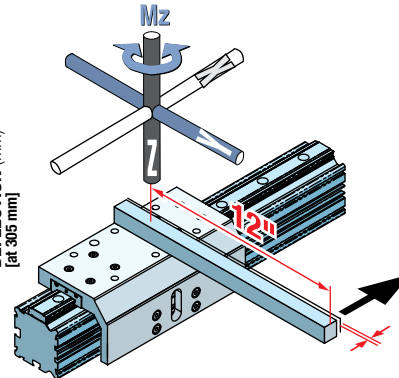
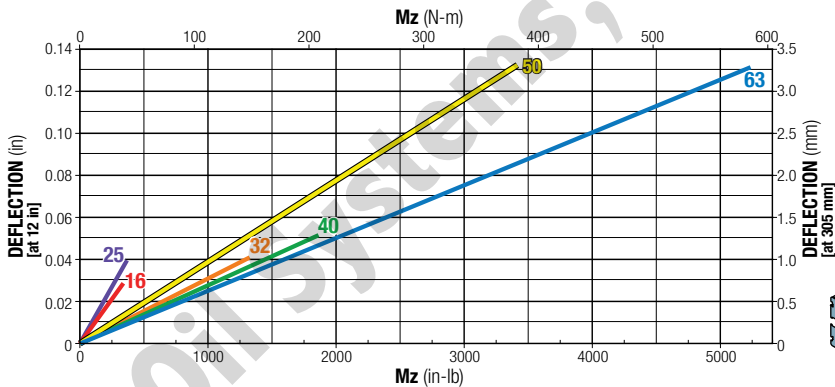

AUXILIARY CARRIER BENDING MOMENTS WITH INCREASED "D" DISTANCE BETWEEN CARRIERS

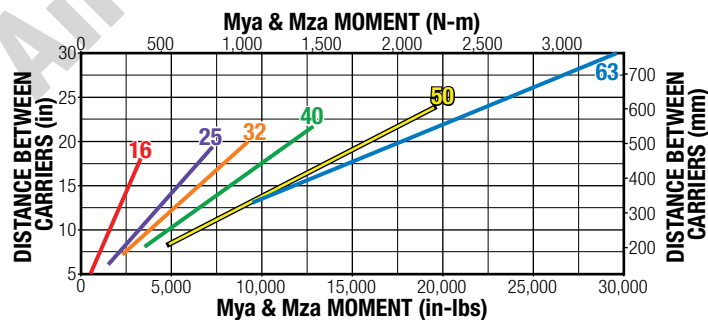

RATINGS WERE CALCULATED UNDER THESE CRITERIA:

- 1.) Coupling between carriers is rigid.
- 2.) Load is equally distributed between carriers.
- 3.) Coupling device applies no misalignment loads to carriers.

MXB-U Belt Driven Actuator

ACTUATOR & OPTION DIMENSIONS

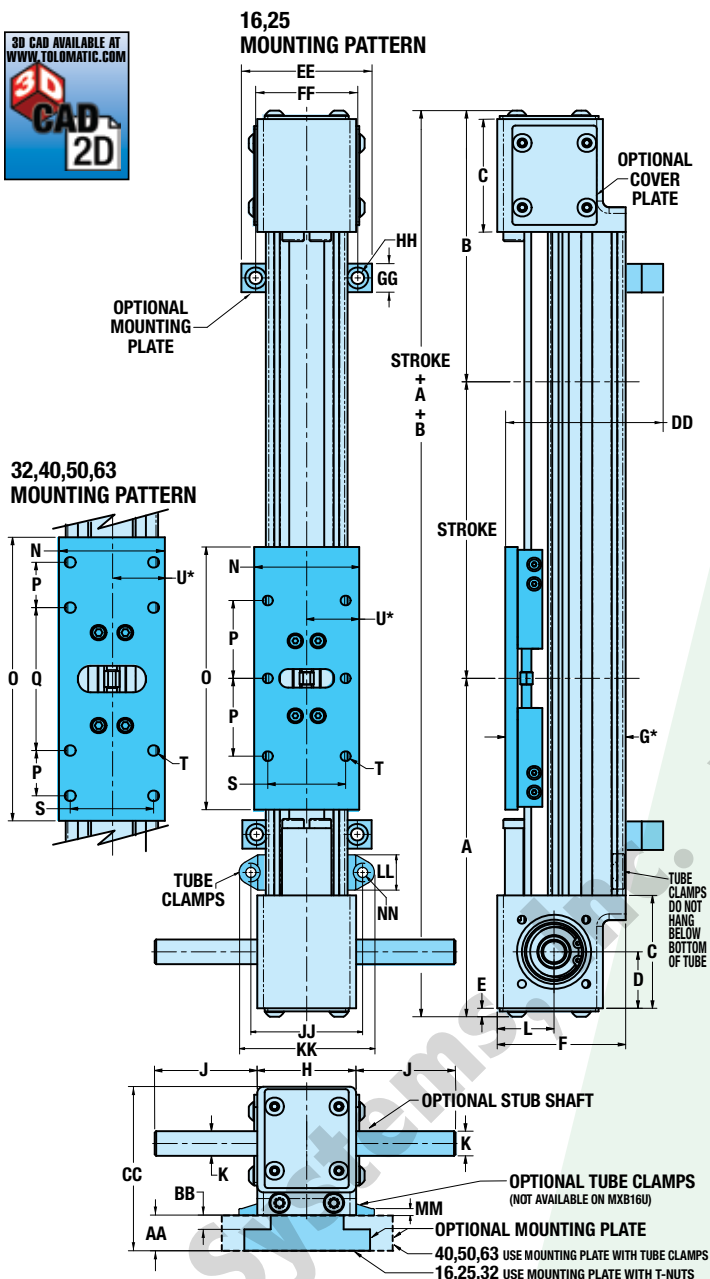

	MXB16	MXB25	MXB32	MXB40	MXB50	MXB63
A	5.33	6.85	7.39	8.53	8.85	10.83
mm	135.3	173.9	187.8	216.6	224.7	275.1
B	4.69	5.49	6.09	7.59	8.07	10.33
mm	119.0	139.3	154.7	192.7	205.0	262.1
C	2.00	2.28	2.20	3.10	3.25	3.79
mm	50.8	58.0	55.9	78.7	82.6	96.1
D	1.00	1.14	1.00	1.55	1.58	1.79
mm	25.4	29.0	25.4	39.4	40.0	45.3
E	0.15	0.17	0.17	0.17	0.17	0.17
mm	3.8	4.4	4.4	4.4	4.4	4.4
F	2.08	2.60	3.05	3.69	4.35	5.48
mm	52.8	66.0	77.5	93.8	110.6	139.3
G*	1.77	2.44	3.05	3.48	4.31	5.34
mm	45.3	61.9	77.4	88.3	109.6	135.5
H	1.75	2.00	2.75	3.25	3.88	4.38
mm	44.5	50.8	69.9	82.6	98.4	111.1
J	**	2.27	2.27	1.87	1.87	1.87
mm	**	57.7	57.7	47.5	47.5	47.5
K	0.375	0.500	0.500	0.500	0.500	0.500
mm	09.53	012.70	012.70	012.70	012.70	012.70
L	1.04	1.15	1.10	1.56	1.63	2.06
mm	26.4	29.2	27.9	39.7	41.5	52.2
N	1.38	2.13	2.50	3.50	3.75	4.50
mm	34.9	54.0	63.5	88.9	95.3	114.3
O	4.33	5.31	6.69	7.87	8.50	12.00
mm	110.0	135.0	170.0	200.0	216.0	304.8
P	1.57	1.57	1.07	1.00	1.00	1.57
mm	40.0	40.0	27.1	25.4	25.4	40.0
Q	-	-	3.37	4.50	2.75	5.12
mm	-	-	87.7	114.3	69.8	130.0
S	1.10	1.57	1.97	2.83	3.13	3.87
mm	28.0	40.0	50.0	72.0	79.4	98.3
T	#8-32(6)	1/4-20(6)	5/16-18(8)	5/16-18(8)	5/16-18(8)	3/8-16(8)
mm	M4x0.7	M6x1.0	M8x1.25	M8x1.25	M8x1.25	M10x1.5
U*	0.69	1.07	1.25	1.75	1.88	2.25
mm	17.5	27.0	31.8	44.5	47.7	57.2

OPTIONAL MOUNTING PLATES

	MXB16	MXB25	MXB32	MXB40	MXB50	MXB63
AA	0.63	0.63	0.75	1.00	1.25	1.00
mm	15.9	15.9	19.1	25.4	31.8	25.4
BB	0.25	0.25	0.30	-	-	-
mm	6.4	6.4	7.6	-	-	-
CC	2.71	3.22	3.80	4.70	5.60	6.48
mm	68.7	81.9	96.5	119.4	119.4	164.6
DD	2.4	3.06	3.75	4.18	5.01	6.04
mm	60.9	77.7	95.2	106.1	127.4	153.3
EE	2.36	2.50	3.40	5.00	5.60	8.00
mm	60.0	63.5	86.4	127.0	142.2	203.2
FF	1.75	2.00	2.75	4.41	5.00	7.00
mm	44.5	50.8	59.9	112.0	127.0	177.8
GG	1.00	1.00	1.00	0.79	0.79	1.00
mm	25.4	25.4	25.4	20.1	20.1	25.4
HH	0.22 THRU □0.37 ▽22 (2)	0.22 THRU □0.37 ▽22 (2)	0.28 THRU □0.44 ▽28 (2)	0.28 THRU (2)	0.28 THRU (2)	0.28 THRU (2)
mm	05.6 THRU □09.4 ▽5.6 (2)	05.6 THRU □09.4 ▽5.6 (2)	07.1 THRU □11.2 ▽7.1 (2)	07.1 THRU (2)	07.1 THRU (2)	07.1 THRU (2)

A *In order for the actuator to operate properly, dimensions "G" and "U" must not vary more than ±0.020 in [0.51mm] over the entire length of the stroke.

**	MXB16
(LMI) J	0.59
mm	15.0
(RP) J	1.83
mm	46.6

OPTIONAL TUBE CLAMPS

	MXB16	MXB25	MXB32	MXB40	MXB50	MXB63
JJ	-	2.24	2.92	3.26	3.84	5.19
mm	-	57.0	74.1	82.7	97.5	131.7
KK	-	2.72	3.44	3.81	4.39	5.93
mm	-	69.0	87.4	96.7	111.5	150.7
LL	-	0.71	0.63	0.55	0.55	0.75
mm	-	18.0	16.0	14.0	14.0	19.0
MM	-	0.14	0.17	0.15	0.15	0.24
mm	-	3.6	4.3	3.8	3.8	6.1
NN	-	0.20	0.28	0.28	0.28	0.42
mm	-	5.2	7.1	7.1	7.1	10.7

MXB-P Belt Driven Actuator

ACTUATOR DIMENSIONS

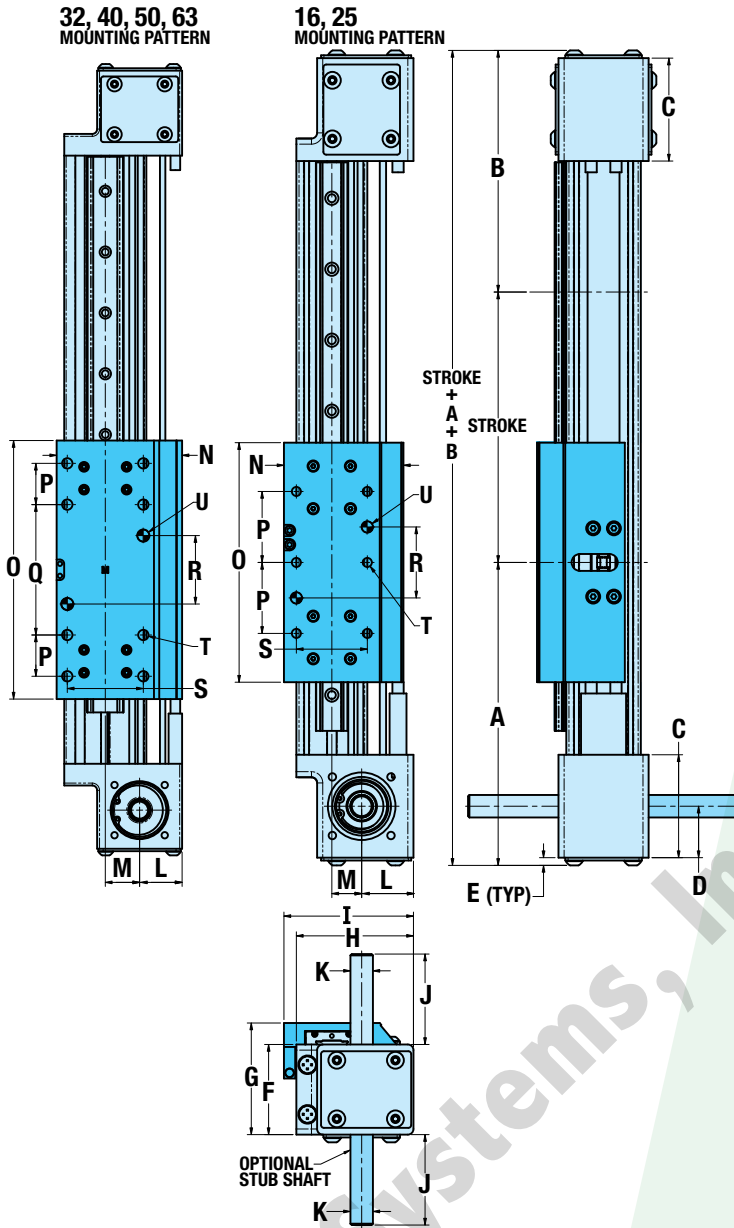

	MXB16	MXB25	MXB32	MXB40	MXB50	MXB63
A	5.33	6.85	7.39	8.53	8.85	10.83
mm	135.3	173.9	187.8	216.6	224.7	275.1
B	4.69	5.49	6.09	7.59	8.07	10.33
mm	119.0	139.3	154.7	192.7	205.0	262.1
C	2.00	2.28	2.20	3.10	3.25	3.79
mm	50.8	58.0	55.9	78.7	82.6	96.1
D	1.00	1.14	1.00	1.55	1.58	1.79
mm	25.4	29.0	25.4	39.4	40.0	45.3
E	0.15	0.17	0.17	0.17	0.17	0.17
mm	3.8	4.4	4.4	4.4	4.4	4.4
F	1.75	2.00	2.75	3.25	3.88	4.38
mm	44.5	50.8	69.9	82.6	98.4	111.1
G	2.10	2.48	3.33	3.88	5.10	5.73
mm	53.2	62.9	84.6	98.7	129.6	145.6
H	2.08	2.60	3.05	3.69	4.35	5.48
mm	52.8	66.0	77.5	93.8	110.6	139.3
I	2.16	2.87	3.25	4.09	4.64	5.79
mm	54.8	73.0	82.5	103.9	117.9	147.1
J	**	2.27	2.27	1.87	1.87	1.87
mm	**	57.7	57.7	47.5	47.5	47.5
K	Ø.375	Ø.500	Ø.500	Ø.500	Ø.500	Ø.500
mm	Ø9.53	Ø12.70	Ø12.70	Ø12.70	Ø12.70	Ø12.70
L	1.04	1.15	1.10	1.56	1.63	2.06
mm	26.4	29.2	27.9	39.7	41.5	52.2
M	0.45	0.66	0.89	0.87	1.17	1.46
mm	11.4	16.8	22.6	22.2	29.8	37.1
N	1.78	2.65	3.25	3.85	4.62	5.93
mm	45.3	67.4	82.5	97.8	117.4	150.6
O	4.33	5.31	6.69	7.87	8.50	12.00
mm	110.0	135.0	170.0	200.0	216.0	304.8
P	1.57	1.57	1.07	1.00	1.00	1.57
mm	40.0	40.0	27.1	25.4	25.4	40.0
Q	—	—	3.37	4.50	2.75	5.12
mm	—	—	87.7	114.3	69.8	130.0
R	1.57	1.57	1.77	2.50	1.50	2.56
mm	40.0	40.0	45.0	63.5	38.1	65.0
S	1.10	1.57	1.97	2.83	3.13	3.87
mm	28.0	40.0	50.0	72.0	79.4	98.3
T	#8-32(6)	1/4-20(6)	5/16-18(8)	5/16-18(8)	5/16-18(8)	3/8-16(8)
mm	M4x0.7	M6x1.0	M8x1.25	M8x1.25	M8x1.25	M10x1.5
U	Ø.1583 / .1573 (2) ↓.250	Ø.2520 / .2510 (2) ↓.250	Ø.3145 / .3135 (2) ↓.375	Ø.3145 / .3135 (2) ↓.500	Ø.3145 / .3135 (2) ↓.500	Ø.3770 / .3760 (2) ↓.500
mm	Ø4.045 / 4.020 ↓6.35	Ø6.045 / 6.020 ↓6.35	Ø8.045 / 8.020 ↓9.53	Ø8.045 / 8.020 ↓12.70	Ø8.045 / 8.020 ↓12.70	Ø10.045 / 10.020 ↓12.70

** MXB16	
(LMI) J	0.59
mm	15.0
(RP) J	1.83
mm	46.6



MXB-P Belt Driven Actuator

OPTION DIMENSIONS

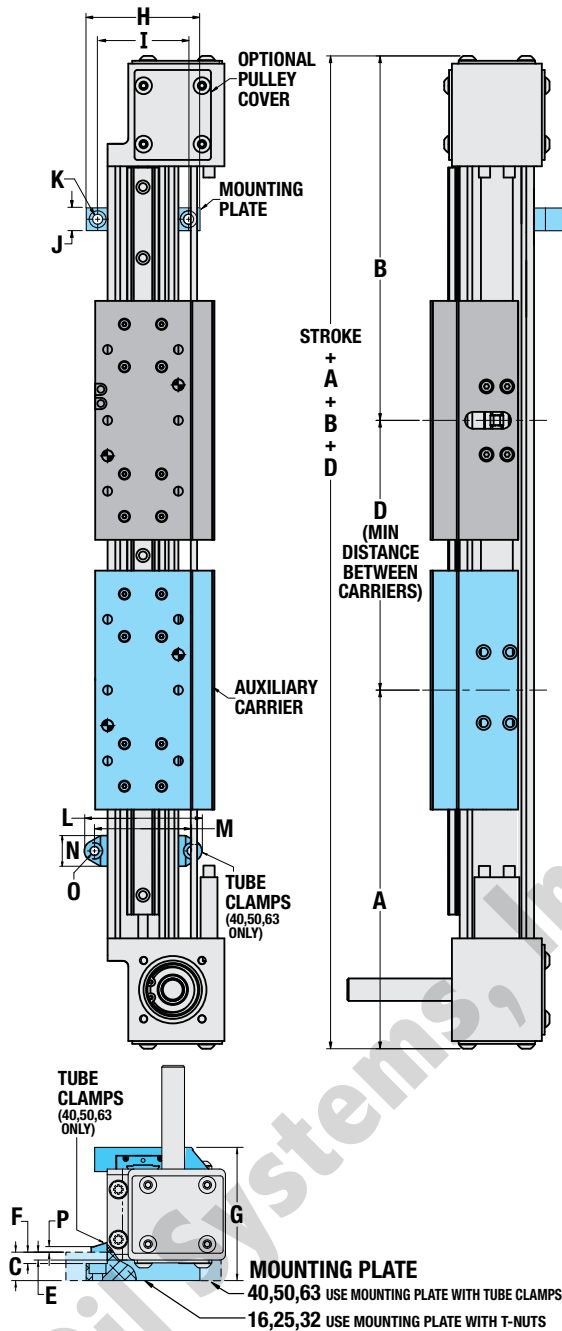

	MXB16	MXB25	MXB32	MXB40	MXB50	MXB63
A	5.33	6.85	7.39	8.53	8.85	10.83
<i>mm</i>	<i>135.3</i>	<i>173.9</i>	<i>187.8</i>	<i>216.6</i>	<i>224.7</i>	<i>275.1</i>
B	4.69	5.49	6.09	7.59	8.07	10.33
<i>mm</i>	<i>119.0</i>	<i>139.3</i>	<i>154.7</i>	<i>192.7</i>	<i>205.0</i>	<i>262.1</i>
AUXILIARY CARRIER						
D	5.00	6.00	7.00	8.50	8.60	13.00
<i>mm</i>	<i>127.0</i>	<i>152.4</i>	<i>177.0</i>	<i>215.9</i>	<i>216.4</i>	<i>330.2</i>
MOUNTING PLATE						
C	0.63	0.63	0.75	1.00	1.25	1.00
<i>mm</i>	<i>15.9</i>	<i>15.9</i>	<i>19.1</i>	<i>25.4</i>	<i>31.8</i>	<i>25.4</i>
E	0.28	0.17	0.29	0.37	0.39	0.22
<i>mm</i>	<i>7.2</i>	<i>4.4</i>	<i>7.2</i>	<i>9.3</i>	<i>9.8</i>	<i>5.6</i>
F	0.25	0.25	0.30	–	–	–
<i>mm</i>	<i>6.4</i>	<i>6.4</i>	<i>7.6</i>	–	–	–
G	2.44	2.93	3.80	4.52	5.96	6.51
<i>mm</i>	<i>61.9</i>	<i>74.4</i>	<i>96.5</i>	<i>114.8</i>	<i>151.4</i>	<i>165.4</i>
H	2.36	2.50	3.40	5.00	5.60	8.00
<i>mm</i>	<i>60.0</i>	<i>63.5</i>	<i>86.4</i>	<i>127.0</i>	<i>142.2</i>	<i>203.2</i>
I	1.75	2.00	2.75	4.41	5.00	7.00
<i>mm</i>	<i>44.5</i>	<i>50.8</i>	<i>69.9</i>	<i>112.0</i>	<i>127.0</i>	<i>177.8</i>
J	1.00	1.00	1.00	0.79	0.79	1.00
<i>mm</i>	<i>25.4</i>	<i>25.4</i>	<i>25.4</i>	<i>20.1</i>	<i>20.1</i>	<i>25.4</i>
K	0.22 THRU └ 0.37 └ 0.22 (2)	0.22 THRU └ 0.37 └ 0.22 (2)	0.28 THRU └ 0.44 └ 0.28 (2)	0.28 THRU (2)	0.28 THRU (2)	0.28 THRU (2)
<i>mm</i>	<i>05.6 THRU</i> └ <i>09.4</i> └ <i>5.6 (2)</i>	<i>05.6 THRU</i> └ <i>09.4</i> └ <i>5.6 (2)</i>	<i>07.1 THRU</i> └ <i>11.2</i> └ <i>7.1 (2)</i>	<i>07.1 THRU (2)</i>	<i>07.1 THRU (2)</i>	<i>07.1 THRU (2)</i>
TUBE CLAMPS						
L	–	–	–	3.81	4.39	5.93
<i>mm</i>	–	–	–	<i>96.8</i>	<i>111.5</i>	<i>150.6</i>
M	–	–	–	3.26	3.84	5.19
<i>mm</i>	–	–	–	<i>82.8</i>	<i>97.5</i>	<i>131.8</i>
N	–	–	–	0.55	0.55	0.75
<i>mm</i>	–	–	–	<i>14.0</i>	<i>14.0</i>	<i>19.1</i>
O	–	–	–	0.28	0.28	0.42
<i>mm</i>	–	–	–	<i>7.1</i>	<i>7.1</i>	<i>10.7</i>
P	–	–	–	0.15	0.15	0.24
<i>mm</i>	–	–	–	<i>3.8</i>	<i>3.8</i>	<i>6.1</i>



MXB Belt Driven Actuator

DIRECT DRIVE MOTOR MOUNTING

MXB 16 / 25 / 32 / 40 / 50 / 63

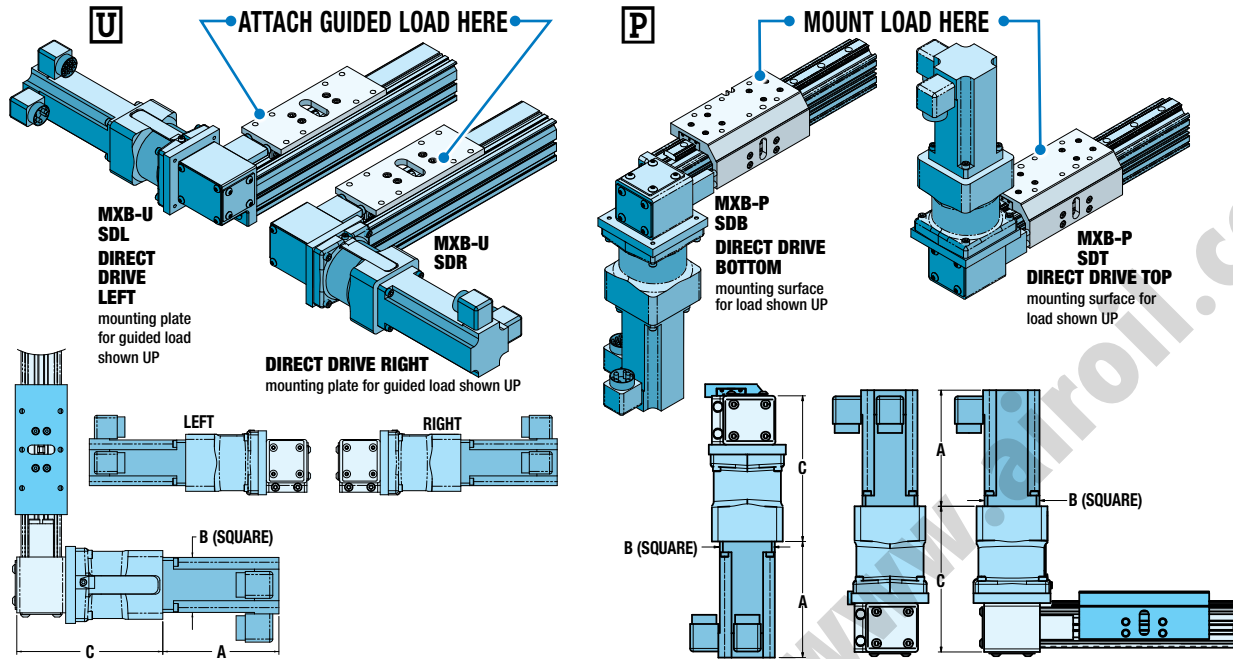

MOTOR	MOTOR DIMENSIONS			
	A		B	
	in	mm	in	mm
MRV21	4.75	120.7	2.25	57.2
MRV22	5.75	146.1	2.25	57.2
MRV23	6.75	171.5	2.25	57.2
MRV24	7.75	196.9	2.25	57.2
MRV31	6.11	155.2	3.54	89.9
MRV32	7.36	186.9	3.54	89.9
MRV33	8.61	218.7	3.54	89.9
MRV51	9.96	253.0	4.75	120.7
MRS21	1.71	43.5	2.22	56.4
MRS22	2.19	55.7	2.22	56.4
MRS23	3.05	77.5	2.22	56.4
MRS31	3.11	79.0	3.38	86.0
MRS32	4.63	117.5	3.38	86.0
MRS33	6.14	156.0	3.38	86.0

ACTUATOR SIZE	MOTOR	C	
		in	mm
16	MRV2_	4.51	114.5
25	MRV2_	5.96	151.4
25	MRV3_	6.17	156.7
25	MRS2_	5.96	151.4
25	MRS3_	5.96	151.4
32	MRV2_	6.71	170.4
32	MRV3_	6.92	175.8
32	MRS2_	6.71	170.4
32	MRS3_	6.71	170.4
40	MRV2_	6.81	173.7
40	MRV3_	7.02	178.3
40	MRS2_	6.81	173.7
40	MRS3_	6.81	173.7
50	MRV2_	7.44	189.0
50	MRV3_	7.65	194.3
50	MRV51	8.75	222.3
50	MRS2_	7.44	189.0
50	MRS3_	7.44	189.0
63	MRV2_	7.94	201.7
63	MRV3_	8.15	207.0
63	MRV51	9.25	235.0
63	MRS2_	7.94	201.7
63	MRS3_	7.94	201.7

MOTOR MOUNTING

The MXB-P is unique among Tolomatic belt driven actuators. The mounting surface of the carrier is located 90° from the motion of the belt. The side opposite the belt is reserved for switch placement. The bottom of the actuator is reserved for mounting. If the motor is mounted in the SDT (direct drive top orientation), be sure the load mounted to the carrier does not interfere with the motor.

LARGE FRAME MOTORS AND SMALLER SIZE ACTUATORS: Cantilevered motors need to be supported if subjected to continuous rapid reversing duty and/or under dynamic conditions.



MXB Belt Driven Actuator

DIRECT DRIVE MOTOR MOUNTING

MXB16

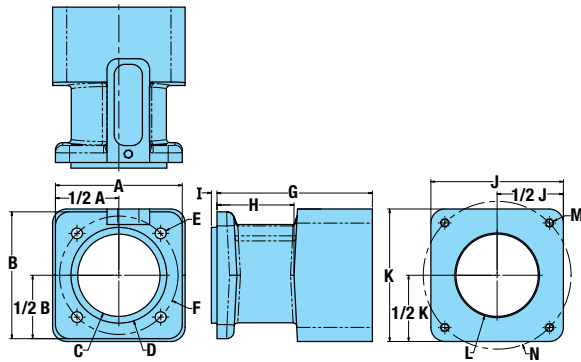

MRV2x	
A	2.25
mm	57.2
B	2.25
mm	57.2
C	Ø1.46
mm	37.1
D	Ø1.70
mm	43.18
E	Ø.19 THRU(4)
mm	4.9
F	Ø2.10
mm	53.34
G	2.76
mm	70.0
H	1.37
mm	34.7
I	0.10
mm	2.5
J	2.35
mm	59.7
K	2.35
mm	59.7
L	Ø1.504
mm	38.20
M	M4x0.7 ↓.39 (4)
mm	M4x0.7 ↓10.0 (4)
N	Ø2.625
mm	66.68

MXB 25 / 32

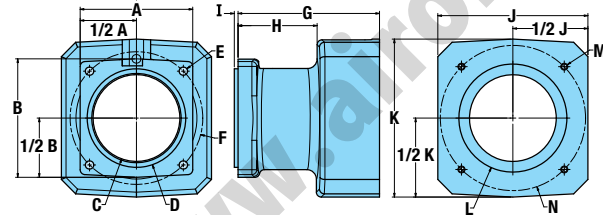
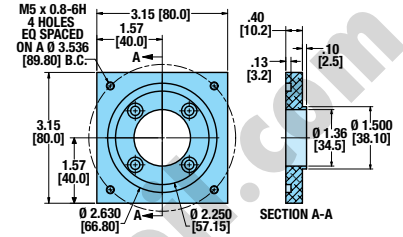
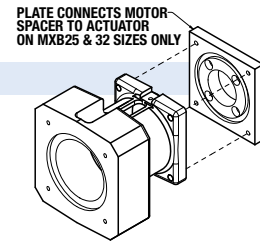

	MRV2x	MRV3x	MRS2x	MRS3x
A	3.00	3.00	3.00	3.00
mm	76.2	76.2	76.2	76.2
B	3.16	3.16	3.16	3.16
mm	80.2	80.2	80.2	80.2
C	Ø2.31	Ø2.31	Ø2.31	Ø2.31
mm	58.7	58.7	58.7	58.7
D	Ø2.627	Ø2.627	Ø2.627	Ø2.627
mm	66.73	66.73	66.73	66.73
E	Ø.22 THRU(4)	Ø.22 THRU(4)	Ø.22 THRU(4)	Ø.22 THRU(4)
mm	5.7	5.7	5.7	5.7
F	Ø3.536	Ø3.536	Ø3.536	Ø3.536
mm	89.81	89.81	89.81	89.81
G	3.56	3.77	3.56	3.56
mm	90.4	95.8	90.4	90.4
H	2.13	2.11	2.13	2.09
mm	54.0	53.5	54.0	53.0
I	0.10	0.10	0.10	0.10
mm	2.5	2.5	2.5	2.5
J	2.81	3.67	2.81	3.51
mm	71.4	93.1	71.4	89.0
K	2.81	3.67	2.81	3.51
mm	71.4	93.1	71.4	89.0
L	Ø1.504	Ø2.879	Ø1.504	Ø2.879
mm	38.20	73.13	38.20	73.13
M	M5 x 0.8 ↓.47 (4)	M5 x 0.8 ↓.47 (4)	M5 x 0.8 ↓.41 (4)	M5 x 0.8 ↓.41 (4)
mm	M5 x 0.8 ↓[11.9] (4)	M5 x 0.8 ↓[11.9] (4)	M5 x 0.8 ↓[10.4] (4)	M5 x 0.8 ↓[10.4] (4)
N	Ø2.625	Ø3.875	Ø2.625	Ø3.875
mm	66.68	98.43	66.68	98.43



MXB Belt Driven Actuator

DIRECT DRIVE MOTOR MOUNTING

MXB 40 / 50 / 63

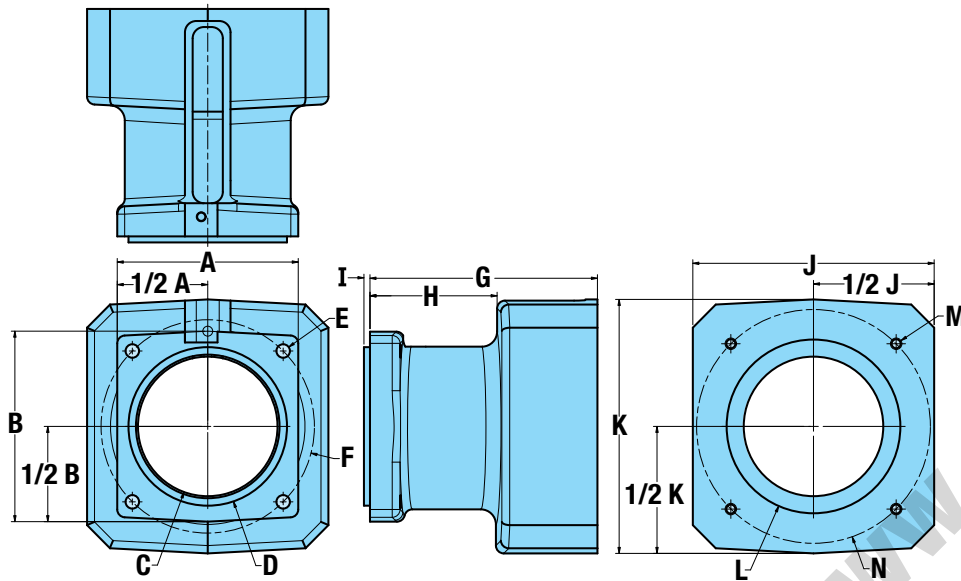

	MRV2x	MRV3x	MRV5x	MRS2x	MRS3x
A	3.00	3.00	3.00	3.00	3.00
mm	76.2	76.2	76.2	76.2	76.2
B	3.16	3.16	3.16	3.16	3.16
mm	80.2	80.2	80.2	80.2	80.2
C	Ø2.31	Ø2.31	Ø2.31	Ø2.31	Ø2.31
mm	58.7	58.7	58.7	58.7	58.7
D	Ø2.627	Ø2.627	Ø2.627	Ø2.627	Ø2.627
mm	66.73	66.73	66.73	66.73	66.73
E	Ø.22 THRU(4)	Ø.22 THRU(4)	Ø.22 THRU(4)	Ø.22 THRU(4)	Ø.22 THRU(4)
mm	5.7	5.7	5.7	5.7	5.7
F	Ø3.536	Ø3.536	Ø3.536	Ø3.536	Ø3.536
mm	89.81	89.81	89.81	89.81	89.81
G	3.56	3.77	4.87	3.56	3.56
mm	90.4	95.8	123.7	90.4	90.4
H	2.13	2.11	2.09	2.13	2.09
mm	54.0	53.5	53.0	54.0	53.0
I	0.10	0.10	0.10	0.10	0.10
mm	2.5	2.5	2.5	2.5	2.5
J	2.81	3.67	5.00	2.81	3.51
mm	71.4	93.1	127.0	71.4	89.0
K	2.81	3.67	5.00	2.81	3.51
mm	71.4	93.1	127.0	71.4	89.0
L	Ø1.504	Ø2.879	Ø4.504	Ø1.504	Ø2.879
mm	38.20	73.13	114.40	38.20	73.13
M	M5 x 0.8 ∇ .47 (4)	M5 x 0.8 ∇ .47 (4)	0.406 THRU (4)	M5 x 0.8 ∇ .41 (4)	M5 x 0.8 ∇ .41 (4)
mm	M5 x 0.8 ∇ [11.9] (4)	M5 x 0.8 ∇ [11.9] (4)	[10.31] THRU (4)	M5 x 0.8 ∇ [10.4] (4)	M5 x 0.8 ∇ [10.4] (4)
N	Ø2.625	Ø3.875	Ø5.875	Ø2.625	Ø3.875
mm	66.68	98.43	149.23	66.68	98.43

MXB-U Belt Driven Actuator

REDUCTION DRIVE MOTOR MOUNTING DIMENSIONS

MXB 16 / 25 / 32 / 40 / 50 / 63

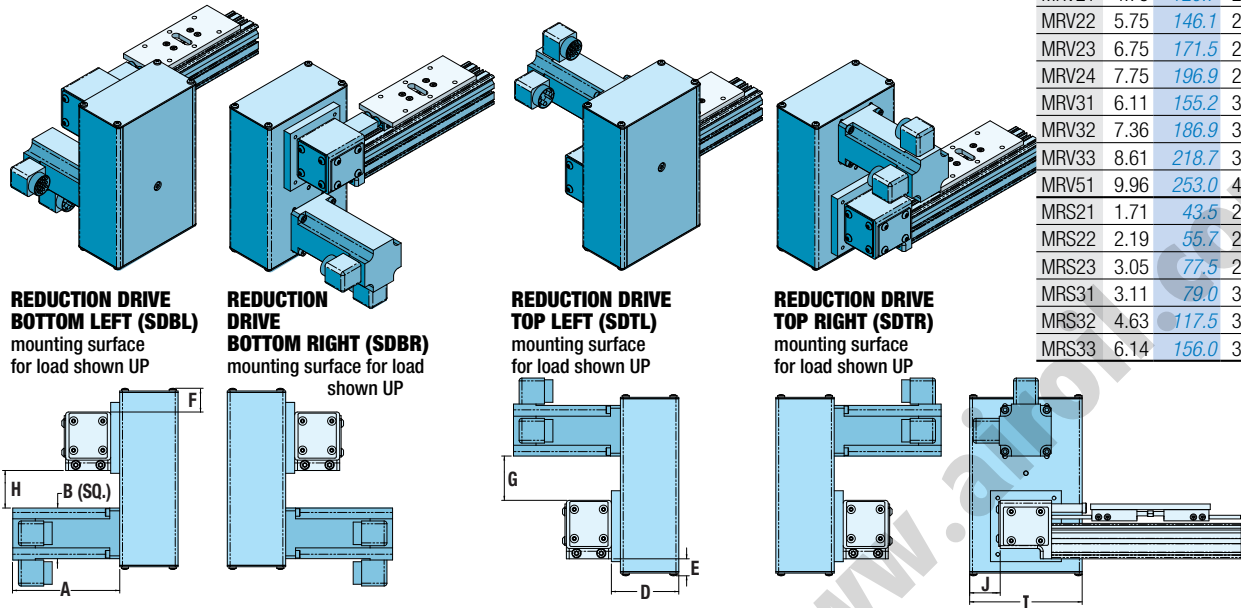

MOTOR	MOTOR DIMENSIONS			
	A		B	
	in	mm	in	mm
MRV21	4.75	120.7	2.25	57.2
MRV22	5.75	146.1	2.25	57.2
MRV23	6.75	171.5	2.25	57.2
MRV24	7.75	196.9	2.25	57.2
MRV31	6.11	155.2	3.54	89.9
MRV32	7.36	186.9	3.54	89.9
MRV33	8.61	218.7	3.54	89.9
MRV51	9.96	253.0	4.75	120.7
MRS21	1.71	43.5	2.22	56.4
MRS22	2.19	55.7	2.22	56.4
MRS23	3.05	77.5	2.22	56.4
MRS31	3.11	79.0	3.38	86.0
MRS32	4.63	117.5	3.38	86.0
MRS33	6.14	156.0	3.38	86.0

ACTUATOR SIZE	MOTOR	D		E		F		G		H		I		J	
		in	mm	in	mm	in	mm	in	mm	in	mm	in	mm	in	mm
16	MRV2_	2.13	54.1	0.82	20.8	0.67	17.0	0.62	15.7	0.62	15.7	3.25	82.6	0.63	16.0
25	MRV2_	2.99*	76.0*	0.75	19.2	1.04	26.5	1.95	49.5	1.65	41.9	5.00	127.0	1.36	34.5
25	MRV3_	2.99*	76.0*	0.75	19.2	1.04	26.5	1.29	32.8	1.02	25.9	5.00	127.0	1.36	34.5
25	MRS2_	2.99*	76.0*	0.75	19.2	1.04	26.5	1.96	49.8	1.66	42.2	5.00	127.0	1.36	34.5
25	MRS3_	2.99*	76.0*	0.75	19.2	1.04	26.5	1.41	35.8	1.11	28.2	5.00	127.0	1.36	34.5
32	MRV2_	2.99*	76.0*	0.25	6.4	1.10	27.9	2.02	51.3	1.17	29.7	5.00	127.0	1.50	38.1
32	MRV3_	2.99*	76.0*	0.25	6.4	1.10	27.9	1.37	34.8	0.52	13.2	5.00	127.0	1.50	38.1
32	MRS2_	2.99*	76.0*	0.25	6.4	1.10	27.9	2.01	51.1	1.16	29.5	5.00	127.0	1.50	38.1
32	MRS3_	2.99*	76.0*	0.25	6.4	1.10	27.9	2.17	55.1	1.32	33.5	5.00	127.0	1.50	38.1
40	MRV2_	2.59	65.8	0.07	1.8	0.64	16.3	1.55	39.4	0.99	25.1	5.00	127.0	0.95	24.1
40	MRV3_	2.59	65.8	0.07	1.8	0.64	16.3	0.91	23.1	0.34	8.6	5.00	127.0	0.95	24.1
40	MRS2_	2.59	65.8	0.07	1.8	0.64	16.3	1.55	39.4	0.98	24.9	5.00	127.0	0.95	24.1
40	MRS3_	2.59	65.8	0.07	1.8	0.64	16.3	1.71	43.4	1.14	29.0	5.00	127.0	0.95	24.1
50	MRV2_	2.59	65.8	—	—	0.57	14.5	1.49	37.8	0.40	10.2	5.00	127.0	0.93	23.6
50	MRV3_	2.59	65.8	—	—	0.57	14.5	1.56	39.6	0.46	11.7	5.00	127.0	0.93	23.6
50	MRV51	2.59	65.8	—	—	0.57	14.5	2.11	53.6	0.74	18.8	5.00	127.0	0.93	23.6
63	MRV2_	2.59	65.8	—	—	0.15	3.8	1.72	43.7	0.35	8.9	5.00	127.0	0.72	18.3
63	MRV3_	2.59	65.8	—	—	0.15	3.8	1.95	49.5	0.57	14.5	5.00	127.0	0.72	18.3
63	MRV51	2.59	65.8	—	—	0.15	3.8	2.12	53.8	0.74	18.8	5.00	127.0	0.72	18.3

* Dimension includes adapter plate (used on 25 & 32). See page 16 for plate dimensions.



MXB-P Belt Driven Actuator

REDUCTION DRIVE MOTOR MOUNTING DIMENSIONS

MXB 16 / 25 / 32 / 40 / 50 / 63

MOTOR	MOTOR DIMENSIONS			
	A		B	
	in	mm	in	mm
MRV21	4.75	120.7	2.25	57.2
MRV22	5.75	146.1	2.25	57.2
MRV23	6.75	171.5	2.25	57.2
MRV24	7.75	196.9	2.25	57.2
MRV31	6.11	155.2	3.54	89.9
MRV32	7.36	186.9	3.54	89.9
MRV33	8.61	218.7	3.54	89.9
MRV51	9.96	253.0	4.75	120.7
MRS21	1.71	43.5	2.22	56.4
MRS22	2.19	55.7	2.22	56.4
MRS23	3.05	77.5	2.22	56.4
MRS31	3.11	79.0	3.38	86.0
MRS32	4.63	117.5	3.38	86.0
MRS33	6.14	156.0	3.38	86.0

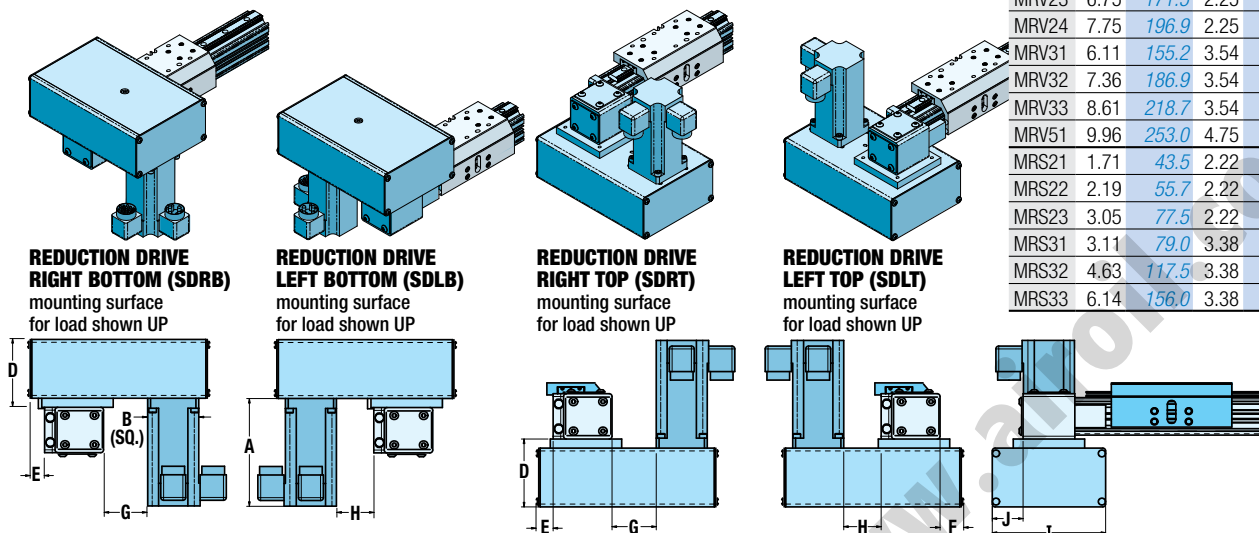

ACTUATOR SIZE	MOTOR	D		E		F		G		H		I		J	
		in	mm	in	mm	in	mm	in	mm	in	mm	in	mm	in	mm
16	MRV2_	2.13	54.1	0.82	20.8	0.67	17.0	0.62	15.7	0.62	15.7	3.25	82.6	0.63	16.0
25	MRV2_	2.99*	76.0*	0.75	19.2	1.04	26.5	1.95	49.5	1.65	41.9	5.00	127.0	1.36	34.5
25	MRV3_	2.99*	76.0*	0.75	19.2	1.04	26.5	1.29	32.8	1.02	25.9	5.00	127.0	1.36	34.5
25	MRS2_	2.99*	76.0*	0.75	19.2	1.04	26.5	1.96	49.8	1.66	42.2	5.00	127.0	1.36	34.5
25	MRS3_	2.99*	76.0*	0.75	19.2	1.04	26.5	1.41	35.8	1.11	28.2	5.00	127.0	1.36	34.5
32	MRV2_	2.99*	76.0*	0.25	6.4	1.10	27.9	2.02	51.3	1.17	29.7	5.00	127.0	1.50	38.1
32	MRV3_	2.99*	76.0*	0.25	6.4	1.10	27.9	1.37	34.8	0.52	13.2	5.00	127.0	1.50	38.1
32	MRS2_	2.99*	76.0*	0.25	6.4	1.10	27.9	2.01	51.1	1.16	29.5	5.00	127.0	1.50	38.1
32	MRS3_	2.99*	76.0*	0.25	6.4	1.10	27.9	2.17	55.1	1.32	33.5	5.00	127.0	1.50	38.1
40	MRV2_	2.59	65.8	0.07	1.8	0.64	16.3	1.55	39.4	0.99	25.1	5.00	127.0	0.95	24.1
40	MRV3_	2.59	65.8	0.07	1.8	0.64	16.3	0.91	23.1	0.34	8.6	5.00	127.0	0.95	24.1
40	MRS2_	2.59	65.8	0.07	1.8	0.64	16.3	1.55	39.4	0.98	24.9	5.00	127.0	0.95	24.1
40	MRS3_	2.59	65.8	0.07	1.8	0.64	16.3	1.71	43.4	1.14	29.0	5.00	127.0	0.95	24.1
50	MRV2_	2.59	65.8	—	—	0.57	14.5	1.49	37.8	0.40	10.2	5.00	127.0	0.93	23.6
50	MRV3_	2.59	65.8	—	—	0.57	14.5	1.56	39.6	0.46	11.7	5.00	127.0	0.93	23.6
50	MRV51	2.59	65.8	—	—	0.57	14.5	2.11	53.6	0.74	18.8	5.00	127.0	0.93	23.6
63	MRV2_	2.59	65.8	—	—	0.15	3.8	1.72	43.7	0.35	8.9	5.00	127.0	0.72	18.3
63	MRV3_	2.59	65.8	—	—	0.15	3.8	1.95	49.5	0.57	14.5	5.00	127.0	0.72	18.3
63	MRV51	2.59	65.8	—	—	0.15	3.8	2.12	53.8	0.74	18.8	5.00	127.0	0.72	18.3

* Dimension includes adapter plate (used on 25 & 32). See page 16 for plate dimensions.



MXB-P Belt Driven Actuator

SWITCHES SPECIFICATIONS

NOTE: Switches NOT available for MXB-**U**



MX products offer a wide range of sensing choices. There are 12 switch choices: reed, solid state PNP (sourcing) or solid state NPN (sinking); in normally open or normally closed; with flying leads or quick-disconnect.

Commonly used for end-of-stroke positioning, these switches allow drop-in installation anywhere along the entire actuator length. The one-piece design includes the retained fastening hardware and is designed for the slot opposite the belt on the MXB (upper slot on 40, 50, 63 sizes). The magnet is located in a slot on the carrier. See the dimensional drawings on page 22 for details of magnet and switch locations. Switches and magnets can be installed in the field at any time.

Switches are used to send digital signals to PLC (programmable logic controller), TTL, CMOS circuit or other controller device. Switches contain reverse polarity protection. Solid state QD cables are shielded; shield should be terminated at flying lead end.

All switches are CE rated and are RoHS compliant. Switches feature bright red or yellow LED signal indicators; solid state switches also have green LED power indicators.



	Order Code	Part Number	Lead	Switching Logic	Power LED	Signal LED	Operating Voltage	**Power Rating (Watts)	Switching Current (mA max.)	Current Consumption	Voltage Drop	Leakage Current	Temp. Range	Shock / Vibration
REED	R Y	8100-9082	5m	SPST Normally Open	—	Red	5 - 240 AC/DC	**10.0	100mA	—	3.0 V max.	—	14 to 158°F [-10 to 70°C]	50 G / 9 G
	R K	8100-9083	QD*											
	N Y	8100-9084	5m	SPST Normally Closed	—	Yellow	5 - 110 AC/DC							
	N K	8100-9085	QD*											
SOLID STATE	T Y	8100-9088	5m	PNP (Sourcing) Normally Open	Green	Yellow	10 - 30 VDC	**3.0	100mA	20 mA @ 24V	2.0 V max.	0.05 mA max.		
	T K	8100-9089	QD*											
	K Y	8100-9090	5m	NPN (Sinking) Normally Open	Green	Red								
	K K	8100-9091	QD*											
	P Y	8100-9092	5m	PNP (Sourcing) Normally Closed	Green	Yellow								
	P K	8100-9093	QD*											
	H Y	8100-9094	5m	NPN (Sinking) Normally Closed	Green	Red								
	H K	8100-9095	QD*											

*QD = Quick-disconnect

Enclosure classification IEC 529 IP67 (NEMA 6)

CABLES: Robotic grade, oil resistant polyurethane jacket, PVC insulation

WARNING: Do not exceed power rating (Watt = Voltage x Amperage). Permanent damage to sensor will occur.

SWITCH INSTALLATION AND REPLACEMENT

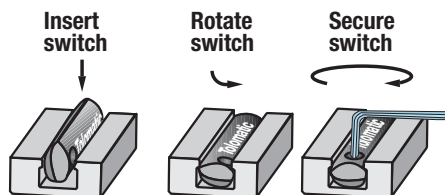

Place switch in side groove on tube at desired location with "Tolomatic" facing outward. While applying light pressure to the switch, rotate the switch halfway into the groove. Maintaining light pressure, rotate the switch in the opposite direction until it is fully inside the groove with "Tolomatic" visible. Re-position the switch to the exact location and lock the switch securely into place by tightening the screw on the switch.

MXB-P Belt Driven Actuator

SWITCHES

WIRING DIAGRAMS

NOTE: Switches NOT available for MXB-U

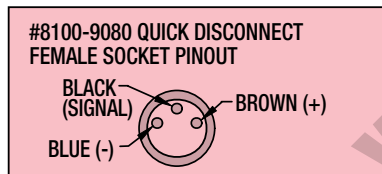
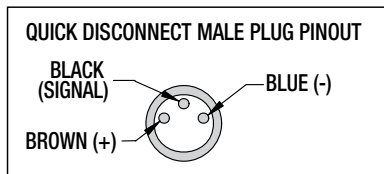
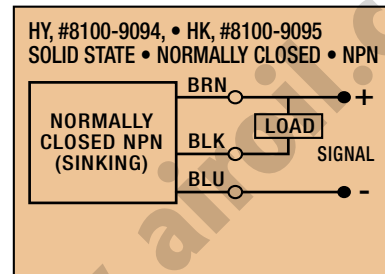
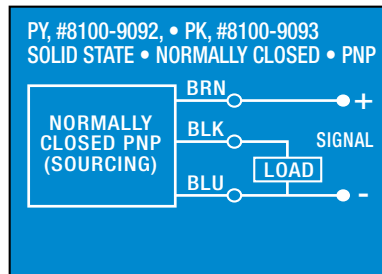
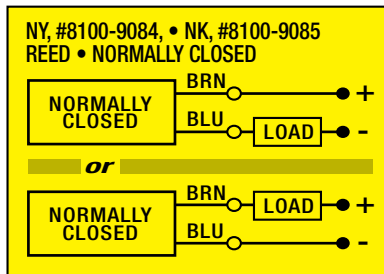
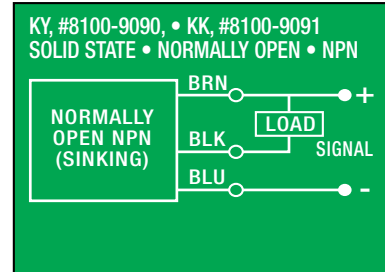
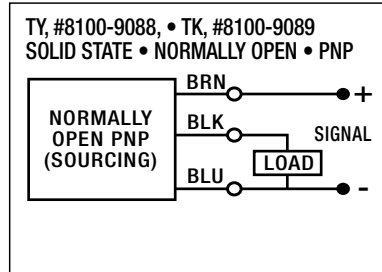
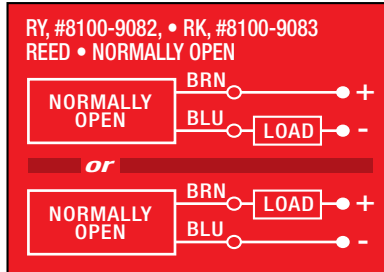

SWITCH DIMENSIONS

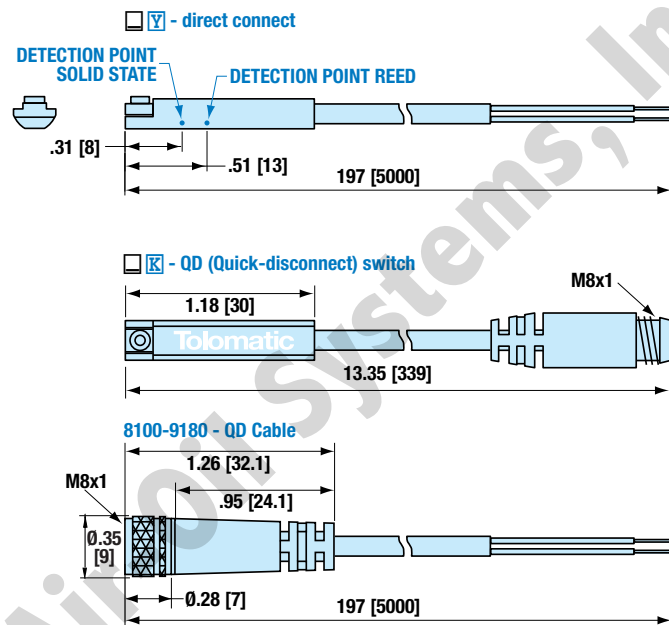

Dimensions in inches [brackets indicate dimensions in millimeters]

MOUNTING DIMENSIONS

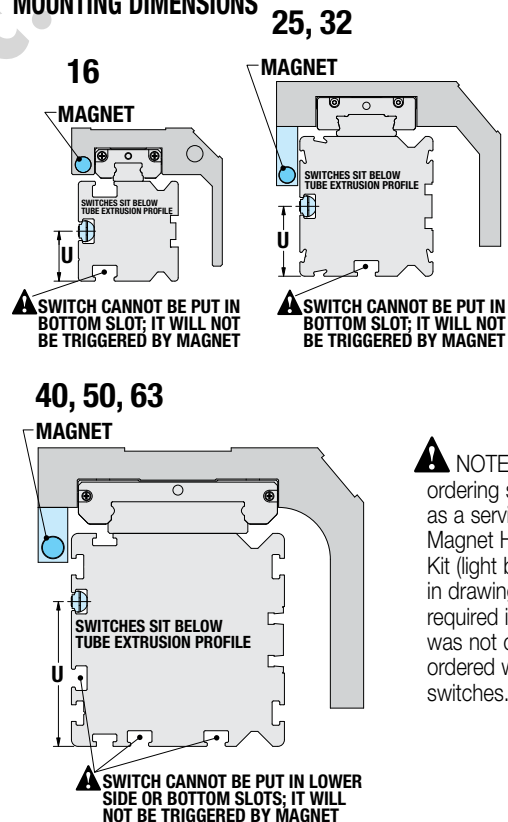

SWITCH MOUNTING

	16	25	32	40	50	63
U	0.31	0.79	1.06	0.81	1.08	1.50
mm	7.9	20.0	27.0	20.5	27.4	38.0

APPLICATION DATA WORKSHEET Fill in known data. Not all information is required for all applications

ORIENTATION

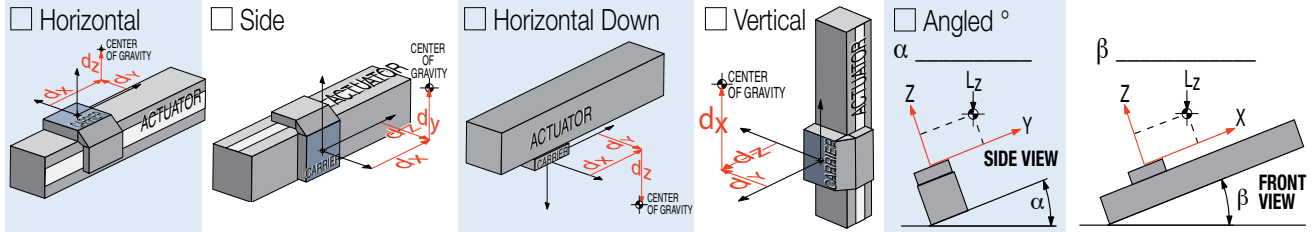

Load attached to carrier OR Load supported by other mechanism

DISTANCE FROM CENTER OF CARRIER TO LOAD CENTER OF GRAVITY

d_x _____
 d_y _____
 d_z _____

inch (U.S. Standard) millimeters (Metric)

STROKE LENGTH

inch (S I) (U.S. Standard) millimeters (S I M) (Metric)

NOTE: If load or force on carrier changes during cycle use the highest numbers for calculations

LOAD

lb. (U.S. Standard) kg. (Metric)

FORCES APPLIED TO CARRIER

lbf. (U.S. Standard) N (Metric)

F_z _____
 F_y _____

BENDING MOMENTS APPLIED TO CARRIER

in.-lbs. (U.S. Standard) N-m (Metric)

M_x _____
 M_y _____
 M_z _____

PRECISION

Repeatability _____
 inch millimeters

OPERATING ENVIRONMENT

Temperature, Contamination, etc.

MOVE PROFILE

Move Distance _____
 inch millimeters

Dwell Time After Move _____

Max. Speed _____
 in/sec mm/sec

MOVE TIME

sec

NO. OF CYCLES

per minute per hour

MOTION PROFILE

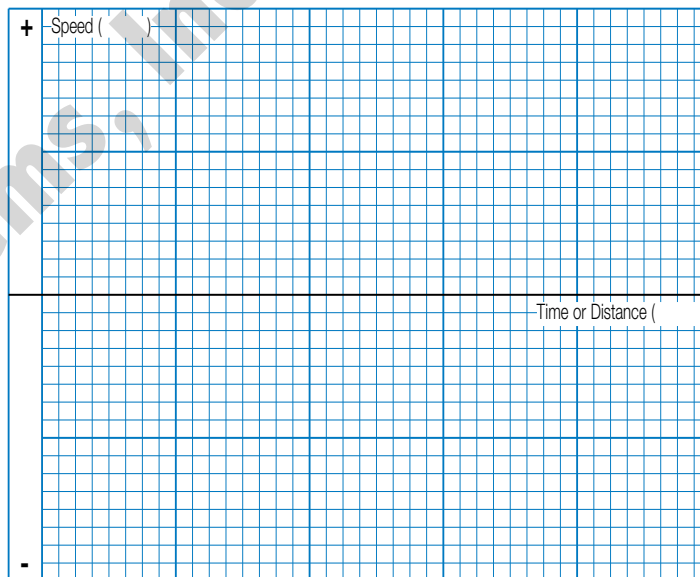

Graph your most demanding cycle, including accel/decel, velocity and dwell times. You may also want to indicate load variations and I/O changes during the cycle. Label axes with proper scale and units.

CONTACT INFORMATION

Name, Phone, Email _____
 Co. Name, Etc. _____



USE THE TOLOMATIC SIZING AND SELECTION SOFTWARE AVAILABLE ON-LINE AT www.tolomatic.com OR... CALL TOLOMATIC AT 1-800-328-2174. We will provide any assistance needed to determine the proper MX actuator for the job.

FAX 1-763-478-8080

EMAIL help@tolomatic.com

SELECTION GUIDELINES

The process of selecting a belt driven actuator for a given application can be complex. **It is highly recommended that you contact Tolomatic or a Tolomatic distributor for assistance in selecting the best actuator for your application.** The following overview of the selection guidelines are for educational purposes only.

1 CHOOSE ACTUATOR SIZE

Choose an actuator that has the thrust, speed and moment load capacity to move the load.

- A) For maximum thrust use the table below.
- B) Maximum speed of MXB-U 200 in/sec (5 m/sec); Maximum speed of MXB-P 150 in/sec (3.8 m/sec).
- C) For MXB-P moment and load capacities see tables on page 10.

SIZE	MAXIMUM THRUST	
	lbf	N
16	38	169
25	151	672
32	209	930
40	250	1112
50	325	1446
63	418	1859

2 COMPARE LOAD TO MAXIMUM LOAD CAPACITIES

Calculate the application load (combination of load mass and forces applied to the carrier) and application bending moments (sum of all moments M_x , M_y , and M_z applied to the carrier). Be sure to evaluate the magnitude of dynamic inertia moments. When a rigidly attached load mass is accelerated or decelerated, its inertia induces bending moments on the carrier. Careful attention to how the load is decelerated at the end of the stroke is required for improved actuator performance and application safety. If either load or any of the moments exceed figures indicated in the Moment and Load Capacity tables (page 10) for the actuator consider:

- 1) A larger actuator size
- 2) Auxiliary carrier
- 3) External guide system (if the load is externally supported and guided, consider using MXB-U)

3 CALCULATE LOAD FACTOR (LF)

For loads with a center of gravity offset from the carrier account for both applied (static) and dynamic loads. The load factor (LF) must not exceed the value of 1.

$$L_f = \frac{M_x}{M_{x_{max}}} + \frac{M_y}{M_{y_{max}}} + \frac{M_z}{M_{z_{max}}} + \frac{F_y}{F_{y_{max}}} + \frac{F_z}{F_{z_{max}}} \leq 1$$

If L_f does exceed the value of 1, consider the three choices listed in step #2.

4 ESTABLISH YOUR MOTION PROFILE AND CALCULATE ACCELERATION RATE

Using the application stroke length and maximum carrier velocity (or time to complete the linear motion), establish the motion profile. Select either triangular (accel-decel) or trapezoidal (accel-constant speed-decel) profile. Now calculate the maximum acceleration and deceleration rates of the move. Acceleration/deceleration should not exceed 1200 in/sec^2 (30.48 m/sec^2). Also, do not exceed safe rates of dynamic inertia moments determined in step #3.

5 SELECT MOTOR (GEARHEAD IF NECESSARY) AND DRIVE

To help select a motor and drive, use the sizing equations located in the Engineering Resources section of the Tolomatic Electric Products Catalog (#3600-4609) to calculate the application thrust and torque requirements. Refer to Motor sections to determine the motor and drive.

6 DETERMINE MOUNTING PLATE REQUIREMENTS

- Consult the Mounting Plate Requirements graph for the model selected (page 9)
- Cross reference the application load and maximum distance between supports
- Select the appropriate number of mounting plates

7 CONSIDER OPTIONS

- Choose metric or inch (U.S. standard) load mounting. When ordering use **S****K** for inch and **S****M** for metric.
- Switches - Reed, Solid State PNP or NPN, all available normally open or normally closed

SPEED FACTOR

FOR APPLICATIONS WITH HIGH SPEED OR SIGNIFICANT SHOCK AND VIBRATION: Calculated values of loads and bending moments must be increased by speed factor from the graph below to obtain full rated life of profiled rail bearing system.

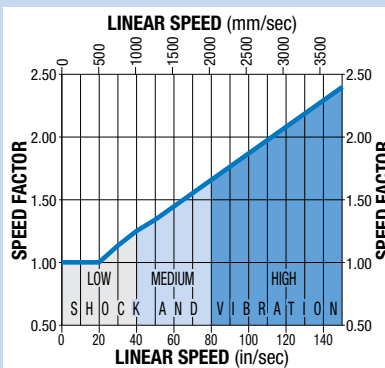

ADD YOUR MOTION CONTROL SYSTEM TO THE MXB or

MRS STEPPER SYSTEM

STEPPER DRIVE AND CONTROLLER

The **DS** [STAC6-S] & **SI** [STAC6-Si] represent the latest developments in stepper drive technology, incorporating features that derive the highest performance from today's stepper motors. Anti-resonance and waveform damping control algorithms provide excellent performance.

- Current Output 0.5 to 6.0 A
- 90-135 VAC Input
- 167V Bus
- Set-up and configuration software
- Configurable idle current reduction
- External control options
- Pulse and direction
- Analog command signal
- Host command via RS232/485
- Integral control options -

Si Programmer™ - intuitive easy-to-use graphical programming language



LATEST IN MICROSTEPPING TECHNOLOGY

- **ANTI-RESONANCE**
Achieves higher speeds and better torque utilization
- **COMMAND SIGNAL SMOOTHING**
Softens effect of changes in velocity and direction
- **MICROSTEP EMULATION**
Smooth, high resolution motion across range of speeds
- **SELF TEST**
Measure motor parameters automatically to optimize system performance
- **TORQUE RIPPLE SMOOTHING**
Adjusts current waveform to reduce low speed torque ripple, providing smoother motion at low speeds

⚠ Please note the Tolomatic ordering codes. Use these codes when ordering stepper components from Tolomatic (Applied Motion Products model equivalents appear in [brackets])

STEPPER ACCESSORIES

HUB MULTI-AXIS MOTION HUB WITH I/O

- Networks Stepper products for multi-axis motion applications



MMI OPERATOR INTERFACE

- Allows visual setup of the panel to show a particular action taking place, or to prompt the user to make a decision or provide information such as move distance, move speed, repeat count



BOB BREAK OUT BOARD

- Connects the I/O points of the **DS** [STAC6-S] & **SI** [STAC6-Si]



STEPPER MOTORS

NEMA 23-Frame and 34-Frame MRS Stepper Motors

- Speeds up to 3,000 RPM
- High resolution (up to 51,200 steps per rev)
- Holding torque to 1845 oz-in (13.03 Nm)
- 2000 line quadrature encoder option
- 10 ft. power cables with connector pre-wired

HYBRID MOTOR DESIGN

- Designed for increased torque and acceleration rates over a wider speed range

INDUSTRY STANDARD MOUNTING

- Standard NEMA frame sizes (23 and 34)

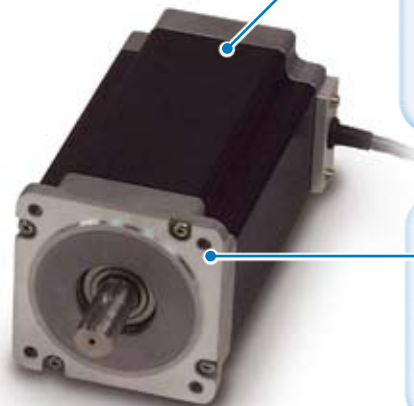

● COMPLETE INFORMATION:
www.tolomatic.com

SELECT A COMPLETE SYSTEM FROM TOLOMATIC

MRV SERVO SYSTEM

DIGITAL SERVO DRIVE AND CONTROLLER

Designed by Tolomatic, the Axiom Plus PV combines the functions of a servo drive, motion controller and programmable logic controller in a single package. Our all-in-one design eliminates the confusion of multiple software packages, removes discrete wiring or network programming between controllers, and simplifies application programming.

The free Windows®-based software package programs the PLC functions in a standard ladder logic environment and the motion control functions in a simple graphical motion editor.



SPECIFICATIONS:

	PV10	PV20	PV30
Input Line	95 - 250 VAC, 1Ø or 3Ø		
Input Hz	47 - 63 Hz		
Output Current Peak (A_{peak})	10	20	30
Output Current Cont (A_{cont})	5	10	15
Output Power Cont (kW)	1.4	2.8	4.2
Discrete Inputs	15, optically isolated 5-25VDC		
Discrete Outputs	8, optically isolated 5-25VDC		
Analog Inputs	1, 14-bit Differential ± 10 VDC		

• INNOVATIVE SERVO TECHNOLOGY •

- **FLUX VECTOR CURRENT CONTROL**
Provides closed loop motor control of torque producing current by sensing motor current in each individual motor phase. This gives a high bandwidth torque response over the full speed range with high efficiency and minimal phase lag
- **PLUGGABLE SCREW TERMINAL BLOCKS**
Allows easier termination, quick connection or removal of wiring and direct access to signals for testing with a meter
- **MODBUS RTU COMMUNICATIONS**
Standard Modbus RTU is built into the drive for communications to other controllers or operator interfaces
- **AMPLIFIER ONLY OPTION**
The DV (drive only) version is for use with an external controller that provides analog velocity, analog torque or step commands

SERVO MOTORS

The MRV series of brushless servo motors is available in a wide range of torque outputs to meet your demanding applications. These motors are designed for precision motion profiles, low inertia, maximum power density and long continuous life.

SPECIFICATIONS:

	TORQUE		Max. Speed (RPM)	Rotor Inertia (lb-in ²)
	Cont. (lb-in)	Peak (lb-in)		
MRV11	3	12	5000	0.02
MRV21	4	11	6000	0.05
MRV22	8	22	6000	0.10
MRV23	11	33	6000	0.14
MRV24	15	47	6000	0.19
MRV31	17	85	6000	0.38
MRV32	30	150	6000	0.69
MRV33	44	220	6000	1.00
MRV51	80	240	3000	2.53

• HIGH RESOLUTION ENCODER •

- 1000 line quadrature industry standard incremental encoder feedback

• INDUSTRY STANDARD MOUNTING •

- Standard NEMA frame sizes (17, 23, 34 and 56)



• INTEGRAL PROTECTION •

- Thermistor provides over temperature protection
- IP65 rated













• **COMPLETE INFORMATION:**
www.tolomatic.com

MXB Belt Driven Actuator

SERVICE PARTS ORDERING

SWITCHES

Switches for MXB include retained mounting hardware and are the same for all actuator sizes and bearing styles

Code	Part Number	Lead	Normally	Sensor Type
	8100-9082	5m (197 in)	Open	Reed
	8100-9083*	Quick-disconnect		
	8100-9084	5m (197 in)	Closed	Reed
	8100-9085*	Quick-disconnect		
	8100-9088	5m (197 in)	Open	Solid State PNP
	8100-9089*	Quick-disconnect		
	8100-9090	5m (197 in)	Open	Solid State NPN
	8100-9091*	Quick-disconnect		
	8100-9092	5m (197 in)	Closed	Solid State PNP
	8100-9093*	Quick-disconnect		
	8100-9094	5m (197 in)	Closed	Solid State NPN
	8100-9095*	Quick-disconnect		

 NOTE: Switches NOT available for MXB-U

 NOTE: When ordering switches as service part, Magnet Housing Kit is required if actuator was not originally ordered with switches

*Also order mating QD cable #8100-9080

	8100-9080	Mating QD (Quick-disconnect) cable 197 in. (5m)
---	-----------	---

OPTIONS

ACTUATOR SIZE	16	25	32	40	50	63
Mounting Plate Kit	8316-9016	8525-9030	8532-9030	8540-9030	8550-9030	8563-9030
**Magnet Housing Kit	8340-1008	8525-9009	8532-9009	8540-9009	8550-9009	8563-9009

***Magnet Housing Kit is required if actuator was not originally ordered with switches (MXB-P only)

MXB Belt Driven Actuator

ORDERING

MODEL SELECTION (MUST BE IN THIS ORDER)

MXB **40** **P** **BWS** **30** **SM** **200** **07** **02**

OPTIONS (IN ANY ORDER)

SDB **DC** **215** **9** **MP** **8** **HCP** **TK** **2**

MODEL
MXB MX Belt Driven Actuator

SERIES
16 Series actuator 40 Series actuator
25 Series actuator 50 Series actuator
32 Series actuator 63 Series actuator

BEARING
U Unguided Carrier
P Profiled Rail

BELT MATERIAL AND WIDTH
BWS10 10 mm Urethane Steel (MXB16)
BWS18 18 mm Urethane Steel (MXB25)
BWS25 25 mm Urethane Steel (MXB32)
BWS30 30 mm Urethane Steel (MXB40)
BWS40 40 mm Urethane Steel (MXB50)
BWS50 50 mm Urethane Steel (MXB63)

STROKE LENGTH & MOUNTING TYPE
SK _____ Stroke, enter desired stroke length in **inches**
SM _____ Stroke, enter desired stroke length in **millimeters**
GPB Blank Plate (MXB-U only)
NO MOUNTING HOLES allowing user to drill and tap as needed
NOTE: Actuator mounting threads and mounting fasteners will be either inch or metric, depending on how stroke length is indicated
SK=inch mounting
SM= metric mounting

MOTOR MOUNTING / REDUCTION
(must choose one)
SDL, SDLD* Direct Drive on Left
SDR, SDRD* Direct Drive on Right
▲ A motor size and code must be selected when specifying a 3:1 reduction. Reference the motor ordering pages in Electric Products Catalog #3600-4609.
SDTL, SDTLD* 3:1 Reduction on Top Left
SDTR, SDTRD* 3:1 Reduction on Top Right
SDBL, SDBLD* 3:1 Reduction on Left Bottom
SDBR, SDBRD* 3:1 Reduction on Right Bottom
***For Dual Stub Shaft Option**

MOTOR MOUNTING / REDUCTION
(must choose one)
SDT, SDTD* Direct Drive on Top
SDB, SDBD* Direct Drive on Bottom
▲ A motor size and code must be selected when specifying a 3:1 reduction. Reference the motor ordering pages in Electric Products Catalog #3600-4609.
SDLT, SDLTD* 3:1 Reduction on Left Top
SDRT, SDRTD* 3:1 Reduction on Right Top
SDLB, SDLBD* 3:1 Reduction on Left Bottom
SDRB, SDRBD* 3:1 Reduction on Right Bottom
***For Dual Stub Shaft Option**

AUXILIARY CARRIER
DC _____ Auxiliary Carrier, (MXB-P only) enter center-to-center spacing desired in **inches** (SK) or **millimeters** (SM)
(Same unit of measure as stroke length is required)
▲ Center-to-center spacing between carriers adds to overall length of the actuator, this distance will not be subtracted from stroke length specified in the previous step

HEAD COVER PLATES
HCP Head Cover Plates

MOUNTING
MP_ Mounting Plates, & quantity
TC_ Tube Clamps, & quantity
NOTE: The MXB requires Mounting Plates to allow clearance for motor when mounted flush to surface. 16,25,32 sizes use T-Nuts with Mounting Plates. 40,50,63 sizes use Tube Clamps with Mounting Plates.

MOTOR / DRIVE / CONTROLLER / PLANETARY GEARBOX
▲ Reference the ordering pages in Electric Products Catalog #3600-4609 Stepper Products Brochure #3600-4160 & Planetary Gearbox Doc. #3600-4161

SWITCHES ("P" bearing only)
RY_ Reed Switch (Normally Open) with 5-meter lead, & enter quantity desired
RK_ Reed Switch (Normally Open) with 5-meter lead/QD, & quantity
NY_ Reed Switch (Normally Closed) with 5-meter lead, & quantity
NK_ Reed Switch (Normally Closed) with 5-meter lead/QD, & quantity
TY_ Solid State Switch PNP (Normally Open) w/ 5-meter lead, & quantity
TK_ Solid State Switch PNP (Normally Open) w/ 5-meter lead/QD, & quantity
KY_ Solid State Switch NPN (Normally Open) w/ 5-meter lead, & quantity
KK_ Solid State Switch NPN (Normally Open) w/ 5-meter lead/QD, & quantity
PY_ Solid State Switch PNP (Normally Closed) w/ 5-meter lead, & quantity
PK_ Solid State Switch PNP (Normally Closed) w/ 5-meter lead/QD, & quantity
HY_ Solid State Switch NPN (Normally Closed) w/ 5-meter lead, & quantity
HK_ Solid State Switch NPN (Normally Closed) w/ 5-meter lead/QD, & quantity

VISIT www.tolomatic.com/mxb
FOR COMPLETE, UP-TO-DATE INFORMATION

▲ Not all codes listed are compatible with all options.

Call Tolomatic 1-800-328-2174 to determine available options and accessories based on your application requirements.

THE TOLOMATIC DIFFERENCE What you expect from the industry leader:



EXCELLENT CUSTOMER SERVICE & TECHNICAL SUPPORT

Our people make the difference! Expect prompt, courteous replies to all of your application and product questions.



INDUSTRY LEADING DELIVERIES

Standard catalog products are built to order and ready-to-ship in 5 days or less. Modified and custom products ship weeks ahead of the competition.



INNOVATIVE PRODUCTS

From standard catalog products... to modified products... to completely unique custom products, Tolomatic designs and builds the best solutions for your challenging applications.



SIZING & SELECTION SOFTWARE

Windows® compatible, downloadable from our website – FREE – the best tool of its kind on the market! Product selection has never been easier.



3D MODELS & 2D DRAWINGS AVAILABLE ON THE WEB

Easy to access CAD files are available in many popular formats.

ALSO CONSIDER THESE OTHER TOLOMATIC PRODUCTS:

PNEUMATIC PRODUCTS



RODLESS CYLINDERS: *Band Cylinders, Cable Cylinders, MAGNETICALLY COUPLED CYLINDERS/SLIDES; GUIDED ROD CYLINDER SLIDES; ROTARY ACTUATORS*
 "FOLDOUT" BROCHURE #9900-9075 MXP BROCHURE #8100-4000 BAND CYLINDER BROCHURE #9900-4015 www.tolomatic.com/pneumatic

ELECTRIC PRODUCTS



ROD & GUIDED ROD STYLE ACTUATORS, HIGH THRUST ACTUATORS, SCREW & BELT DRIVE RODLESS ACTUATORS, MOTORS, AXIOM DRIVES/CONTROLLERS

"FOLDOUT" BROCHURE #9900-9074 PRODUCTS BROCHURE #9900-4016 MXE BROCHURE #8300-4000 STEPPER PRODUCTS #3600-4160 www.tolomatic.com/electric

POWER TRANSMISSION PRODUCTS



GEARBOXES: *Float-A-Shaft®, Slide-Rite®, DISC CONE CLUTCH; CALIPER DISC BRAKE*

"FOLDOUT" BROCHURE #9900-9076 SLIDE-RITE® GEARBOX BROCHURE #0100-4006 SLIDE-RITE® CROSS REF. #0100-4005 CATALOG #9900-4009 www.tolomatic.com/pt



3800 County Road 116 • Hamel, MN 55340 U.S.A.
 Phone: (763) 478-8000 • Fax: (763) 478-8080

Toll-Free: **1-800-328-2174**

Email: help@tolomatic.com • <http://www.tolomatic.com>

All brand and product names are trademarks or registered trademarks of their respective owners. Information in this document is believed accurate at time of printing. However, Tolomatic assumes no responsibility for its use or for any errors that may appear in this document. Tolomatic reserves the right to change the design or operation of the equipment described herein and any associated motion products without notice. Information in this document is subject to change without notice.

Visit www.tolomatic.com for the most up-to-date technical information

