

Regulator

R26

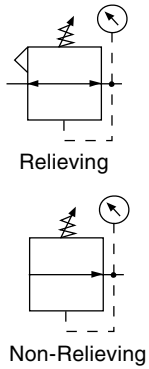

R26-02-000

Features

- Non-Rising Adjustment Knob with Friction Lock Knob
- Standard with Two Full Flow 1/4" NPT / BSPT-Rc Gauge Ports
- Panel Mount Nut
- High Flow Capacity
- Balanced Valve Design for Excellent Regulation Characteristics

WARNING

Product rupture can cause serious injury.
Do not connect regulator to bottled gas.
Do not exceed maximum primary pressure rating.

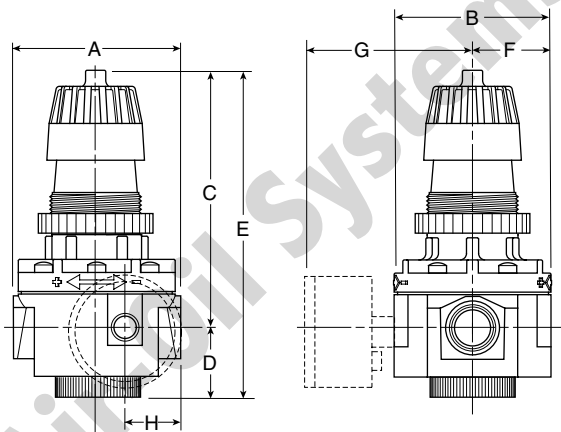

NOTE: 1.88" Dia. (47.8 mm) hole required for panel nut mounting.

Dimensions

Models	Inches (mm)	A	B	C	D	E	F	G	H
Standard Unit R26-XX-000		3.35 (85)	3.10 (79)	5.13 (130.3)	1.35 (34)	6.48 (165)	1.55 (39.4)	— —	1.13 (28.7)
With Gauge R26-XX-G00		3.35 (85)	3.10 (79)	5.13 (130.3)	1.35 (34)	6.48 (165)	1.55 (39.4)	3.13 (79.5)	1.13 (28.7)

= "Most Popular"

Specifications

Flow Capacity*	1/4	112 SCFM (53 dm ³ /s)
	3/8	148 SCFM (70 dm ³ /s)
	1/2	185 SCFM (87 dm ³ /s)
Adjusting Range Pressure		0 to 60 PSIG (0 to 4.1 bar)
		0 to 125 PSIG (0 to 8.6 bar)
		0 to 250 PSIG (0 to 17.2 bar)

Gauge Port (2 ea.)	NPT / BSPT-Rc	1/4
Operating Temperature	32° to 150°F (0° to 65.5°C)	
Maximum Supply Pressure	300 PSIG (21 bar)	
Port Size	NPT / BSPP-G	1/4, 3/8, 1/2
Weight	lb. (kg)	2.5 (1.34)

* Inlet pressure 100 PSIG (6.9 bar). Secondary pressure 90 PSIG (6.2 bar).

Materials of Construction

Body	Zinc
Bonnet	PBT
Diaphragm	Nitrile / Zinc
Panel Nut	Acetal
Seals	Nitrile
Springs	Steel
Valve Assembly	Brass / Nitrile / Acetal

CAUTION:

REGULATOR PRESSURE ADJUSTMENT – The working range of knob adjustment is designed to permit outlet pressures within their full range. Pressure adjustment beyond this range is also possible because the knob is not a limiting device. This is a common characteristic of most industrial regulators, and limiting devices may be obtained only by special design.

For best performance, regulated pressure should always be set by increasing the pressure up to the desired setting.

 = "Most Popular"

Replacement Kits

- Diaphragm Assembly –
 - Non-relieving RRP-96-332
 - Self-relieving..... RRP-96-238
- Knob, Adjusting –
 - Used on Units with Plastic Bonnets..... RRP-95-023
- Spring, Regulating –
 - 0 to 60 PSIG (0 to 4,1 bar)..... RRP-95-962
 - 0 to 125 PSIG (0 to 8,6 bar) GRP-95-225
 - 0 to 250 PSIG (0 to 17,2 bar)..... RRP-95-219
- Valve Assembly –
 - Valve, Valve Spring, Bottom Plug O-ring..... RRP-96-294

Accessories

- Gauge, Pressure –
 - 0 to 60 PSIG (0 to 4 bar), 2" Dial Face, 1/4 NPT, CBM.....K4520N14060
 - 0 to 160 PSIG (0 to 11 bar), 2" Dial Face, 1/4 NPT, CBM..... K4520N14160
 - 0 to 300 PSIG (0 to 20 bar), 2" Dial Face, 1/4 NPT, CBM.....K4520N14300
- Nut, Panel Mount, Plastic RRP-95-954
- Tamper Resistant Kit –
 - Ring Style used on Plastic Bonnets..... RPA-95-006
- Wall Mounting Bracket –
 - C-typeGPA-95-051
 - C-typeRPA-95-947
 - L-Type – Heavy Duty GPA-95-956
- Wall Mounting Bracket, Gauge Port Adapter, 1/4 NPT..... RRP-95-590

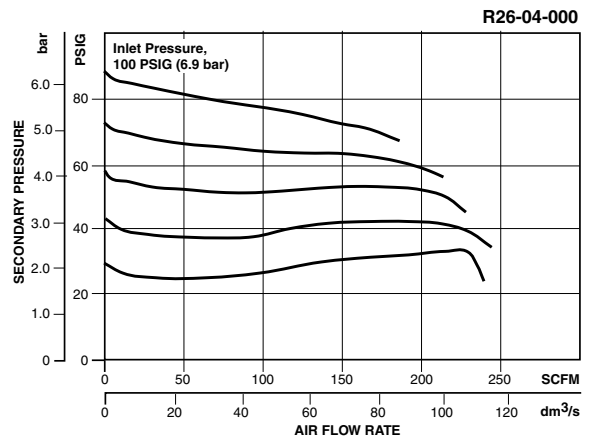
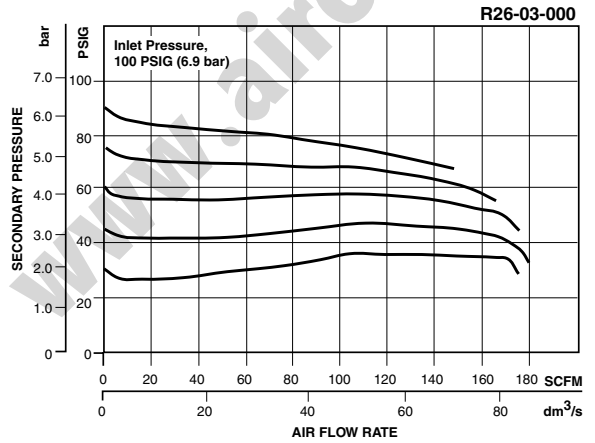
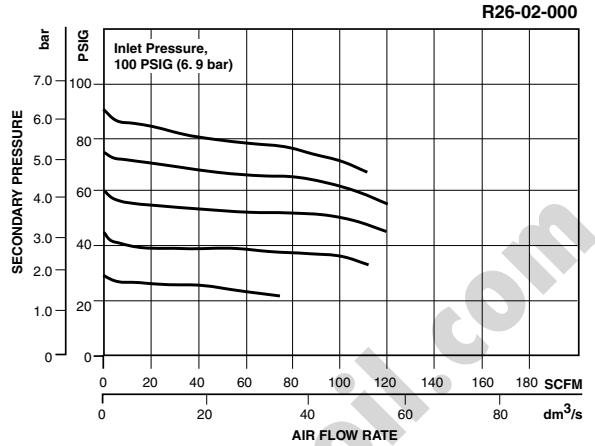

Ordering Information

Model Type	Port Size	Without Gauge 5 to 125 PSIG (0.4 to 8.6 bar)	Without Gauge 10 to 250 PSIG (0.7 to 17.2 bar)	Without Gauge 3 to 60 PSIG (0.2 to 4.1 bar)	With Gauge 5 to 125 PSIG (0.4 to 8.6 bar)	With Gauge 10 to 250 PSIG (0.7 to 17.2 bar)	With Gauge 3 to 60 PSIG (0.2 to 4.1 bar)
Relieving	1/4	R26-02-000	R26-02-H00	R26-02-L00	R26-02-G00	R26-02-GH0	R26-02-GL0
	3/8	R26-03-000	R26-03-H00	R26-03-L00	R26-03-G00	R26-03-GH0	R26-03-GL0
	1/2	R26-04-000	R26-04-H00	R26-04-L00	R26-04-G00	R26-04-GH0	R26-04-GL0
Non-relieving	1/4	R26-02-N00	R26-02-HN0	R26-02-LN0	R26-02-GN0	R26-02-GHN	R26-02-GLN
	3/8	R26-03-N00	R26-03-HN0	R26-03-LN0	R26-03-GN0	R26-03-GHN	R26-03-GLN
	1/2	R26-04-N00	R26-04-HN0	R26-04-LN0	R26-04-GN0	R26-04-GHN	R26-04-GLN

Options - To order an option supplied with the unit model, add the appropriate coded suffix letter in the designated position of the model number.

