

# Regulator R40

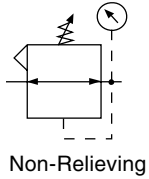
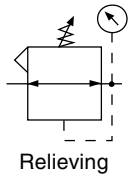

**R40-0B-000**

## Features

- Balanced Valve Design
- Standard Self-Relieving
- Two 1/4 NPT / BSPT-Rc Gauge Ports Standard – Can Be Used for Additional Outlet Ports
- Piston Operated
- High Flow Capacity

### **⚠ WARNING**

**Product rupture can cause serious injury.  
Do not connect regulator to bottled gas.  
Do not exceed maximum primary pressure rating.**

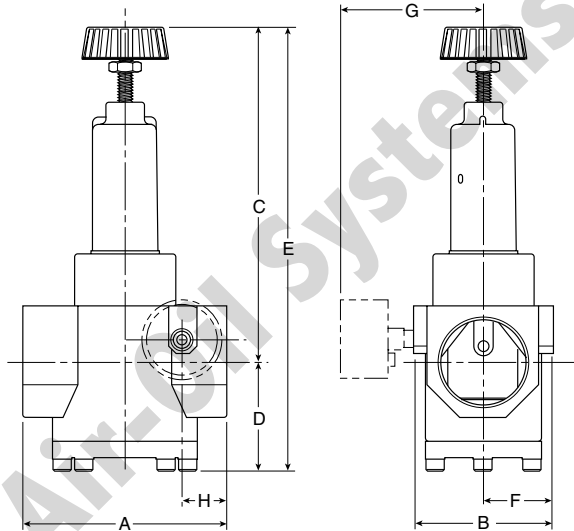

## Dimensions

Models	Inches (mm)	A	B	C	D	E	F	G	H
Standard Unit R40-XX-000		5.31 (135)	3.58 (91)	9.09 (230.8)	2.79 (71)	11.88 (302)	— —	1.29 (33)	1.15 (29.2)
With Gauge (order separately) R40-XX-XXX		5.31 (135)	3.58 (91)	9.09 (230.8)	2.79 (71)	11.88 (302)	4.02 (102)	1.29 (33)	1.15 (29.2)

= "Most Popular"

## Specifications

Flow Capacity*	1-1/2, 2	1200 SCFM (566 dm <sup>3</sup> /s)
Adjusting Range Pressure	0 to 125 PSIG (0 to 8.6 bar)	0 to 180 PSIG (0 to 12.4 bar)
Maximum Supply Pressure	300 PSIG (20.7 bar)	
Operating Temperature	32° to 150°F (0° to 65.5°C)	
Port Size	NPT / BSPP-G	1-1/2, 2
Gauge Port (2 ea.)	NPT / BSPT-Rc	1/4
Weight	lb. (kg)	10.8 (4.9)

\* Inlet pressure 100 PSIG (6.9 bar). Secondary pressure 85 PSIG (5.9 bar).

## Materials of Construction

Body	Zinc
Bonnet	Zinc
Piston	Zinc
Seals	Nitrile
Springs	Steel
Valve Assembly	Brass / Nitrile / Acetal

## CAUTION:

**REGULATOR PRESSURE ADJUSTMENT** – The working range of knob adjustment is designed to permit outlet pressures within their full range. Pressure adjustment beyond this range is also possible because the knob is not a limiting device. This is a common characteristic of most industrial regulators, and limiting devices may be obtained only by special design.

For best performance, regulated pressure should always be set by increasing the pressure up to the desired setting.

= "Most Popular"

### Replacement Kits

- Piston Assembly –
  - Non-relieving ..... RRP-95-451
  - Relieving ..... RRP-95-964
- Spring, Regulating –
  - 0 to 125 PSIG (0 to 8.6 bar) ..... RRP-95-226
  - 0 to 180 PSIG (0 to 12.4 bar)..... RRP-95-220
- Spring, Valve ..... RRP-95-024
- Valve Assembly (Non-relieving) –
  - Valve, Valve Spring ..... RRP-95-162
- Valve Assembly (Self-relieving) –
  - Valve, Valve Spring, Ret. Ring, O-rings..... RRP-95-161

### Accessories

- Gauge, Pressure –
  - 0 to 160 PSIG (0 to 11 bar), 2" Dial Face,  
1/4 NPT, CBM..... K4520N14160
  - 0 to 300 PSIG (0 to 20 bar), 2" Dial Face,  
1/4 NPT, CBM.....K4520N14300
- Wall Mounting Bracket, Gauge Port Adapter,  
1/4 NPT..... RRP-95-590

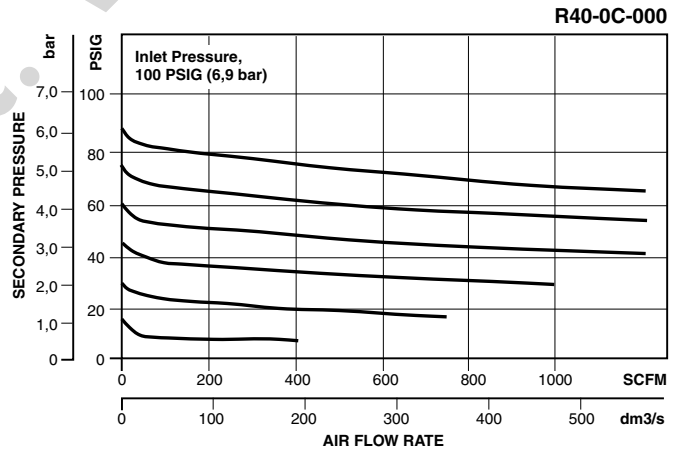
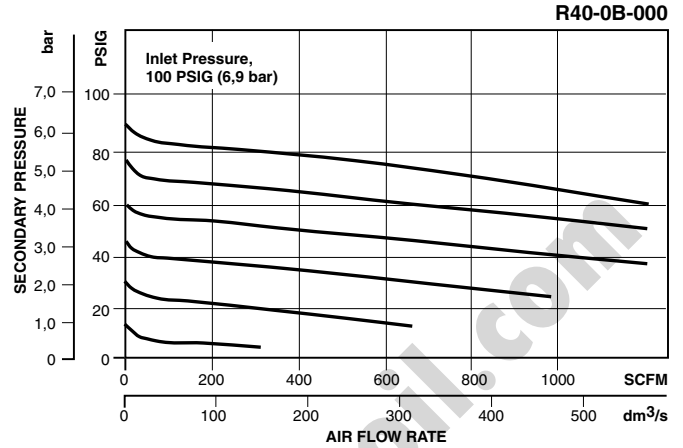

### Ordering Information

Model Type	Port Size	Without Gauge 10 to 125 PSIG (0.7 to 8.6 bar)	High Pressure 10 to 180 PSIG (0.7 to 12.4 bar)
Relieving	1-1/2	R40-0B-000	R40-0B-H00
	2	R40-0C-000	R40-0C-H00
Non-relieving	1-1/2	R40-0B-N00	R40-0B-HN0
	2	R40-0C-N00	R40-0C-HN0

Options - To order an option supplied with the unit model, add the appropriate coded suffix letter in the designated position of the model number.

